



ARICA

Sprint

Ed. 87

meccanica CATALOGO PARTI RICAMBIO

1-1989



1037 ANNULLA E SOSTITUISCE LA 1019

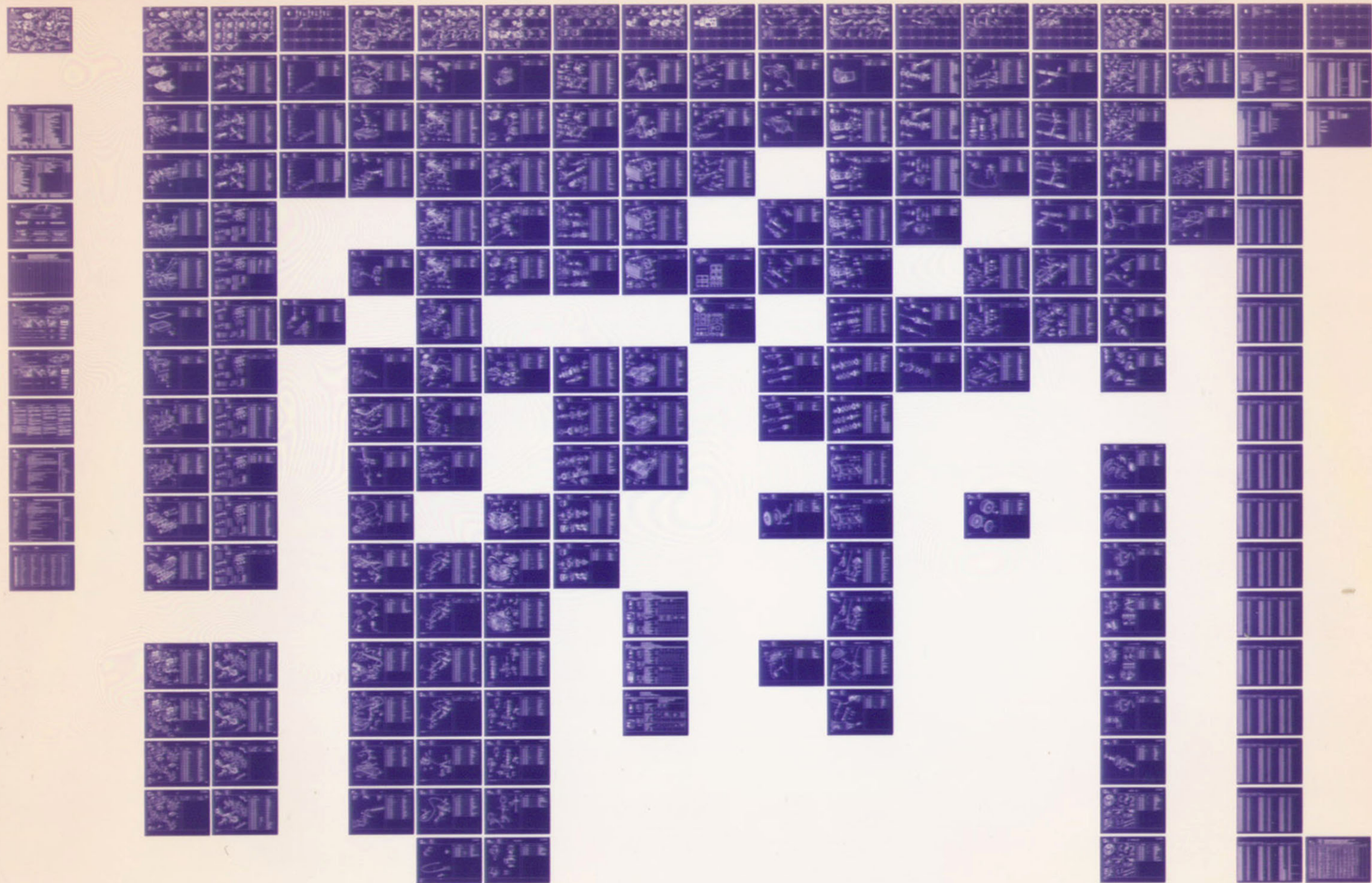

A
9-1987

A-B

USO DEL CATALOGO
UTILISATION DU CATALOGUE
HOW TO USE THE CATALOG
GEBRAUCH DES KATALOGOS
USO DEL CATALOGO

C

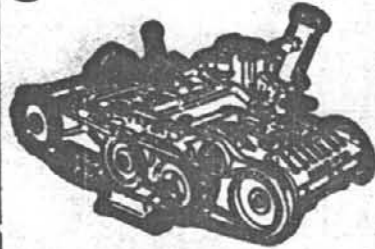

D

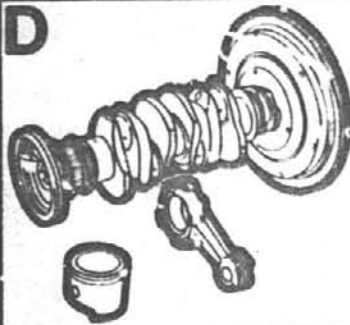

E

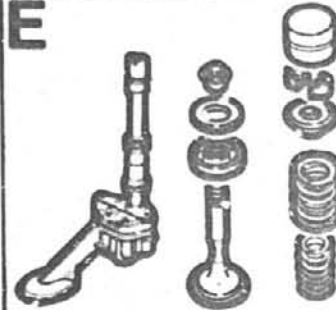

F

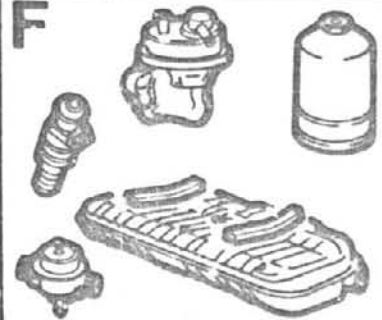

G

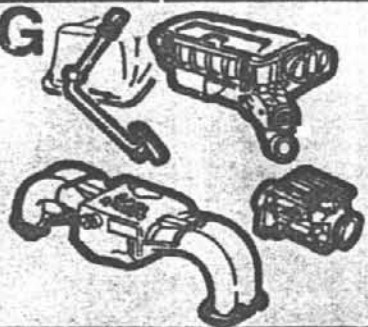

H

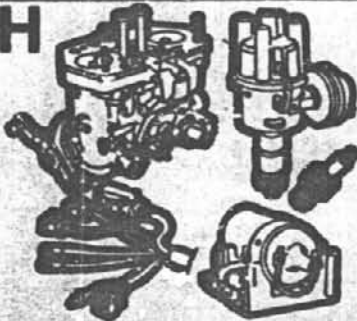

I

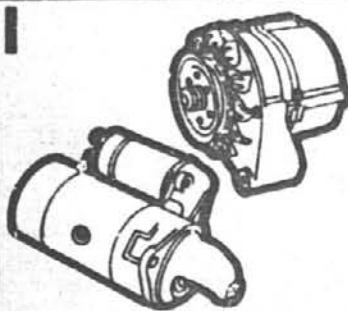

J

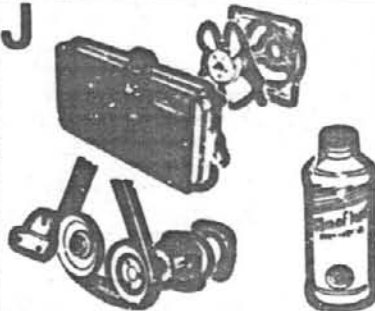

K

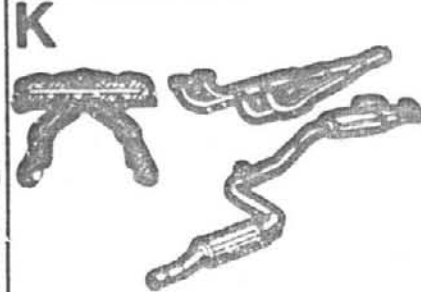

L

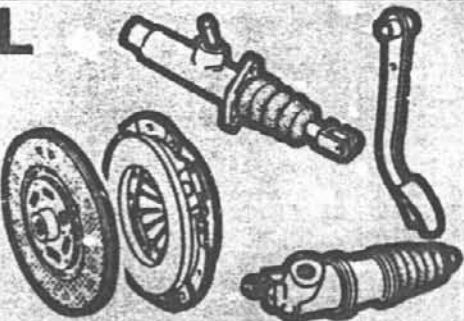

M

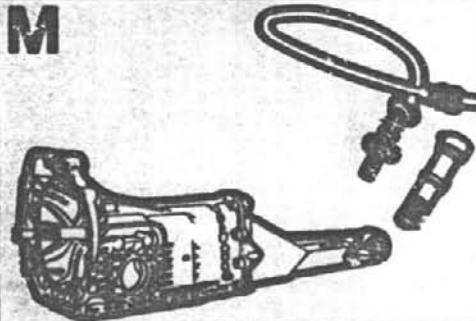

N

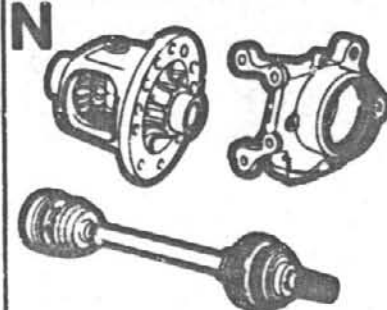

O

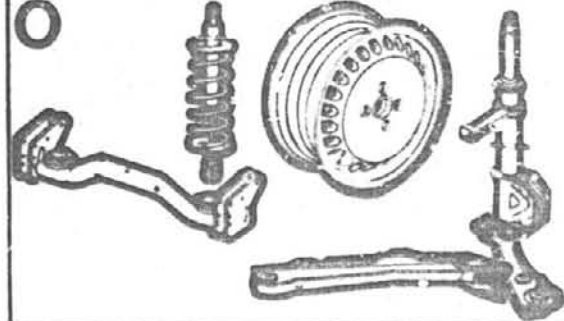

P

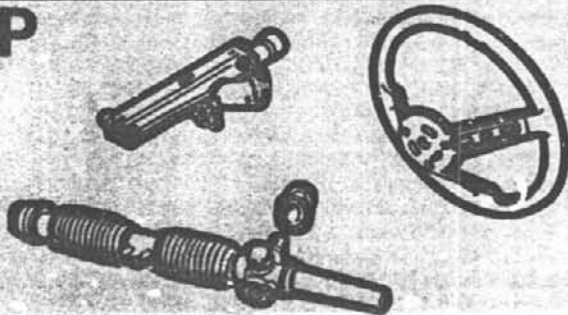

Q

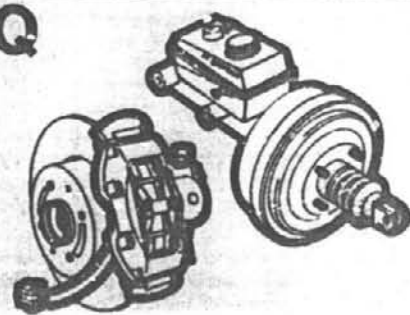

R

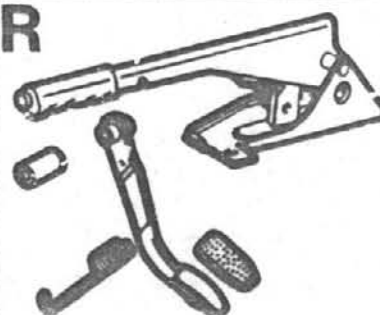

S-T

INDICE NUMERICO
REPERTOIRE NUMERIQUE
NUMERICAL INDEX
NUMMERISCHES SACHVERZEICHNIS
INDICE NUMERICO

A2

SPRINT
Ed. 87
MECCANICA

1 - 1989

MICROFICHES IN VIGORE 21 - 1 - 1989

Microfiches en force - Microfiches in force - Gultige Mikrofiches - Microfiches en vigor

| 1 | 2 | 3 | 4 | 5 | 1 | 2 | 3 | 4 | 5 |
|------|---|-----------------|-----------|------|------|--|-----------------|-----------|------|
| 0170 | ★ F12 | 3 ^A | 6 - 1982 | 0068 | 0647 | SPIDER 2.0 M.Y. 82 USA VERSION (CARROZZERIA) | 10 ^A | 12 - 1987 | 0694 |
| 0182 | ★ GIULIA DIESEL | 4 ^A | 6 - 1982 | 0069 | 0848 | SPIDER 2.0 M.Y. 83/84 USA VERSION (MECCANICA) | 8 ^A | 12 - 1987 | 0695 |
| 0193 | ★ ALFETTA GT | 5 ^A | 7 - 1982 | 0127 | 0849 | SPIDER 2.0 M.Y. 83/84 USA VERSION (CARROZZERIA) | 8 ^A | 12 - 1987 | 0696 |
| 0201 | ★ ALFASUD - ALFASUD L - ALFASUD 5M | 7 ^A | 9 - 1982 | 0147 | 0850 | ALFETTA BLINDATA (MECCANICA) | 5 ^A | 12 - 1987 | 0701 |
| 0204 | ★ ALFASUD TI | 4 ^A | 9 - 1982 | 0150 | 0851 | ALFETTA BLINDATA (CARROZZERIA) | 5 ^A | 12 - 1987 | 0702 |
| 0205 | ★ ALFASUD SPRINT | 5 ^A | 9 - 1982 | 0151 | 0873 | ALFETTA (MECCANICA) | 9 ^A | 2 - 1988 | 0764 |
| 0207 | ★ ALFETTA 2.0 | 5 ^A | 9 - 1982 | 0136 | 0874 | ALFETTA (CARROZZERIA) | 9 ^A | 2 - 1988 | 0765 |
| 0225 | ★ ALFETTA BERLINA 2000 USA VERSION | 4 ^A | 12 - 1982 | 0154 | 0918 | GIULIETTA 81 - 82 - T.D. - 83 - 84 (MECCANICA) | 8 ^A | 5 - 1988 | 0836 |
| 0304 | ★ ALFETTA 1.6 | 5 ^A | 8 - 1983 | 0187 | 0919 | GIULIETTA 81 - 82 - T.D. - 83 - 84 (CARROZZERIA) | 7 ^A | 5 - 1988 | 0757 |
| 0319 | ★ ALFASUD GIARDINETTA | 4 ^A | 9 - 1983 | 0190 | 0927 | ALFA 90 BLINDATA (MECCANICA) | 4 ^A | 6 - 1988 | 0875 |
| 0336 | ★ ALFETTA - ALFETTA 1.8 | 7 ^A | 11 - 1983 | 0208 | 0928 | ALFA 90 BLINDATA (CARROZZERIA) | 4 ^A | 6 - 1988 | 0876 |
| 0344 | ★ ALFETTA GTV 2000 USA VERSION | 5 ^A | 12 - 1985 | 0211 | 0940 | SPIDER 2.0 M.Y.88 USA VERSION (MECCANICA) | 3 ^A | 7 - 1988 | 0889 |
| 0366 | ★ SPIDER JUNIOR 1.3/1.6 | 4 ^A | 1 - 1984 | 0218 | 0941 | SPIDER 2.0 M.Y.88 USA VERSION (CARROZZERIA) | 3 ^A | 7 - 1988 | 0890 |
| 0375 | ★ SPIDER VELOCE 2000 | 4 ^A | 2 - 1984 | 0210 | 0942 | ALFA 6 (MECCANICA) | 12 ^A | 7 - 1988 | 0789 |
| 0383 | ★ ALFETTA 2.0 USA VERSION | 5 ^A | 3 - 1984 | 0233 | 0943 | ALFA 6 (CARROZZERIA) | 12 ^A | 7 - 1988 | 0790 |
| 0481 | ★ ALFETTA 2.0 LI | 6 ^A | 12 - 1984 | 0347 | 0944 | ALFA 6 TURBO DIESEL 5 (MECCANICA) | 11 ^A | 7 - 1988 | 0786 |
| 0484 | ★ ALFETTA GT 1.6 | 9 ^A | 1 - 1985 | 0348 | 0945 | ALFA 6 2.5 - 2.0 (MECCANICA) | 10 ^A | 7 - 1988 | 0787 |
| 0485 | ★ ALFETTA GTV 2000 | 8 ^A | 1 - 1985 | 0369 | 0946 | ALFA 6 '83 (CARROZZERIA) | 10 ^A | 7 - 1988 | 0788 |
| 0502 | ★ ALFASUD SUPER | 9 ^A | 3 - 1985 | 0390 | 0947 | GTV 6 2.5 M.Y.81 - 84 USA VERSION (MECCANICA) | 18 ^A | 7 - 1988 | 0864 |
| 0503 | ★ ALFASUD TI 1.3/1.5 | 9 ^A | 3 - 1985 | 0381 | 0948 | GTV 6 2.5 M.Y.81 - 84 USA VERSION (CARROZZERIA) | 18 ^A | 7 - 1988 | 0865 |
| 0504 | ★ ALFASUD SPRINT 1.3/1.5 | 9 ^A | 3 - 1985 | 0382 | 0949 | 75 SUPER (MECCANICA) | 5 ^A | 7 - 1988 | 0895 |
| 0513 | ★ 2000 SPIDER VELOCE USA VERSION | 8 ^A | 5 - 1985 | 0426 | 0950 | 75 SUPER (CARROZZERIA) | 5 ^A | 7 - 1988 | 0896 |
| 0514 | ★ ALFETTA TURBO DIESEL | 9 ^A | 5 - 1985 | 0427 | 0951 | MILANO C.A. M.Y.88 (MECCANICA) | 3 ^A | 7 - 1988 | 0887 |
| 0515 | ★ ALFETTA BERLINA 1.6/1.8 (MIGLIORATA) | 7 ^A | 5 - 1985 | 0428 | 0952 | MILANO M.Y.88 (CARROZZERIA) | 3 ^A | 7 - 1988 | 0888 |
| 0516 | ★ GIULIETTA (MECCANICA) | 10 ^A | 5 - 1985 | 0436 | 0953 | 33 T.D. SUPER (MECCANICA) | 6 ^A | 7 - 1988 | 0891 |
| 0517 | ★ GIULIETTA (CARROZZERIA) | 10 ^A | 5 - 1985 | 0437 | 0954 | 33 SUPER (MECCANICA) | 5 ^A | 7 - 1988 | 0892 |
| 0518 | ★ ALFETTA 2.0 L | 10 ^A | 5 - 1985 | 0438 | 0955 | 33 SUPER BERLINA (CARROZZERIA) | 6 ^A | 7 - 1988 | 0893 |
| 0527 | ★ AUTOCARRO GAMMA AR8 2 ^A S (CARROZZERIA) | 2 ^A | 7 - 1985 | 0329 | 0956 | 33 SUPER BREAK (CARROZZERIA) | 5 ^A | 7 - 1988 | 0894 |
| 0528 | ★ FURGONE - COMBI - BUS - GAMMA AR 8 2 ^A S (CARROZZERIA) | 2 ^A | 7 - 1985 | 0330 | 0957 | SPIDER 1.6/2.0 Ed.80 - 85 (MECCANICA) | 14 ^A | 8 - 1988 | 0791 |
| 0529 | ★ VEICOLI GAMMA AR 8 1 ^A 2 ^A S (MECCANICA) | 6 ^A | 7 - 1985 | 0355 | 0958 | SPIDER 1.6/2.0 Ed.80 - 85 (CARROZZERIA) | 14 ^A | 8 - 1988 | 0792 |
| 0559 | ★ AUTOCARRO GAMMA AR 8 (CARROZZERIA) | 7 ^A | 11 - 1985 | 0331 | 0959 | GTV 2.0 - 2.5 Ed.85 (MECCANICA) | 6 ^A | 8 - 1988 | 0871 |
| 0590 | ★ FURGONI - COMBI - BUS - GAMMA AR 8 (CARROZZERIA) | 7 ^A | 11 - 1985 | 0332 | 0960 | GTV 2.0 - 2.5 Ed.85 (CARROZZERIA) | 6 ^A | 8 - 1988 | 0872 |
| 0582 | GAMMA AR 6 (MECCANICA) | 2 ^A | 11 - 1985 | 0505 | 0961 | 75 SUPER G.D. - C.A. (MECCANICA) | 3 ^A | 8 - 1988 | 0906 |
| 0584 | GAMMA AR 6 (CARROZZERIA) | 2 ^A | 11 - 1985 | 0506 | 0962 | MILANO 3.0 M.Y.88 USA VERSION (MECCANICA) | 3 ^A | 8 - 1988 | 0907 |
| 0585 | AR 8 TURBO (MECCANICA) | 1 ^A | 11 - 1985 | | 0963 | MILANO 3.0 M.Y.88 USA VERSION (CARROZZERIA) | 3 ^A | 8 - 1988 | 0908 |
| 0586 | AR 8 TURBO (CARROZZERIA) | 1 ^A | 11 - 1985 | | 0967 | SPIDER 2.0 M.Y.86 USA VERSION (MECCANICA) | 5 ^A | 9 - 1988 | 0860 |
| 0739 | ARNA (MECCANICA) | 10 ^A | 3 - 1987 | 0647 | 0968 | SPIDER 2.0 M.Y.86 USA VERSION (CARROZZERIA) | 9 ^A | 9 - 1988 | 0851 |
| 0740 | ARNA (CARROZZERIA) | 10 ^A | 3 - 1987 | 0648 | 0969 | SPIDER 2.0 M.Y.87 USA VERSION (MECCANICA) | 6 ^A | 9 - 1988 | 0862 |
| 0809 | GIULIETTA 2.0 TURBO DELTA (MECCANICA) | 5 ^A | 10 - 1987 | 0675 | 0970 | SPIDER 2.0 M.Y.87 USA VERSION (CARROZZERIA) | 6 ^A | 9 - 1988 | 0863 |
| 0810 | GIULIETTA 2.0 TURBO DELTA (CARROZZERIA) | 4 ^A | 10 - 1987 | 0676 | 0971 | GTV 6 2.5 M.Y.86 USA VERSION (MECCANICA) | 9 ^A | 9 - 1988 | 0916 |
| 0846 | SPIDER 2.0 M.Y. 82 USA VERSION (MECCANICA) | 10 ^A | 12 - 1987 | 0693 | 0972 | GTV 6 2.5 M.Y.86 USA VERSION (CARROZZERIA) | 9 ^A | 9 - 1988 | 0917 |

| | | | | | |
|-------------------------------|---|---|--|---|--|
| 1 Numero N. No. Nr. N. | 2 Modello vettura Modèle de voiture Vehicletype Fahrzeugtyp Tipo automovil | 3 Edizione Edition Edition Ausgabe Edición | 4 Data emissione Date de l'emission Lussing date Ausgabendatum Fecha de emision | 5 Precedente edizione Edicion précédente Previous edition Vorherige ausgabe Edicion precedente | ★ Il presente catalogo non avrà più successivi aggiornamenti Ce catalogue ne sera plus mis a jour This catalog will be no longer updated Dieser katalog wird keine kurrent haltung mehr haben Este catalogo no tendrá mas puestas al día |
|-------------------------------|---|---|--|---|--|

A3

SPRINT
Ed. 87
MECCANICA

1 - 1989

MICROFICHES IN VIGORE 21 - 1 - 1989

Microfiches en force - Microfiches in force - Gultige Mikrofiches - Microfiches en vigor



| 1 | 2 | 3 | 4 | 5 | 1 | 2 | 3 | 4 | 5 |
|------|--|-----------------|-----------|------|------|---|----------------|-----------|------|
| 0973 | ALFA 75 (MECCANICA) | 11 ^A | 9 - 1988 | 0920 | 1022 | 33 1.7 Q.V. (CARROZZERIA) | 7 ^A | 10 - 1988 | 0937 |
| 0974 | ALFA 75 (CARROZZERIA) | 11 ^A | 9 - 1988 | 0921 | 1023 | 33 1.7 I.E. (MECCANICA) | 4 ^A | 10 - 1988 | 0938 |
| 0975 | ALFA 75 TURBO E (MECCANICA) | 3 ^A | 9 - 1988 | 0801 | 1024 | 33 1.7 I.E. (CARROZZERIA) | 4 ^A | 10 - 1988 | 0939 |
| 0976 | ALFA 75 TURBO E (CARROZZERIA) | 3 ^A | 9 - 1988 | 0802 | 1027 | 75 Ed.88 c.c. 1.6 - 1.8 Carburatori (MOTORE) | 2 ^A | 1 - 1989 | 0988 |
| 0977 | ALFASUD 3 ^{AS} - BERLINA - TI - SPRINT (MECCANICA) | 16 ^A | 9 - 1988 | 0839 | 1028 | 75 Ed.88 c.c. 2.0 T.Spark/ c.c.1.8 I.E. / c.c.1.8 TURBO(MOTORE) | 2 ^A | 1 - 1989 | 0989 |
| 0978 | ALFASUD 3 ^{AS} BERLINA 3/4/5 P - TI 2/3 P (CARROZZERIA) | 14 ^A | 9 - 1988 | 0840 | 1029 | 75 Ed.88 c.c.2.5 - c.c.3.0 (MOTORE) | 2 ^A | 1 - 1989 | 0990 |
| 0979 | ALFA 33 (MECCANICA) | 16 ^A | 9 - 1988 | 0883 | 1030 | 75 Ed.88 T.D. c.c.2.0 - c.c.2.4 (MOTORE) | 2 ^A | 1 - 1989 | 0991 |
| 0980 | ALFA 33 (CARROZZERIA) | 16 ^A | 9 - 1988 | 0884 | 1031 | 75 Ed.88 GRUPPI TELAIO (MECCANICA) | 2 ^A | 1 - 1989 | 0992 |
| 0981 | ALFA 33 4x4 - 4x2 BERLINA/BREAK(MECCANICA) | 14 ^A | 9 - 1988 | 0885 | 1032 | 75 Ed. 88 (CARROZZERIA) | 2 ^A | 1 - 1989 | 0993 |
| 0982 | ALFA 33 4x4 - 4x2 BERLINA/BREAK (CARROZZERIA) | 14 ^A | 9 - 1988 | 0886 | 1033 | 164 (MECCANICA) | 6 ^A | 1 - 1989 | 1025 |
| 0983 | 33 T.D. 1.8 Ed.88 (MECCANICA) | 2 ^A | 9 - 1988 | 0912 | 1034 | 164 (CARROZZERIA) | 6 ^A | 1 - 1989 | 1026 |
| 0984 | 33 Ed.88 (MECCANICA) | 2 ^A | 9 - 1988 | 0913 | 1035 | 164 TURBO (MECCANICA) | 3 ^A | 1 - 1989 | 0966 |
| 0985 | 33 1.7 I.E. Ed.88 (MECCANICA) | 2 ^A | 9 - 1988 | 0914 | 1036 | SPRINT Ed. 87 (CARROZZERIA) | 5 ^A | 1 - 1989 | 1020 |
| 0986 | 33 Ed.88 BERLINA (CARROZZERIA) | 2 ^A | 9 - 1988 | 0915 | 1037 | SPRINT Ed. 87 (MECCANICA) | 5 ^A | 1 - 1989 | 1019 |
| 0987 | 33 SPORT WAGON (CARROZZERIA) | 2 ^A | 9 - 1988 | 0911 | | | | | |
| 0994 | MILANO C.A. M.Y.89 (MECCANICA) | 1 ^A | 9 - 1988 | | | | | | |
| 0995 | MILANO M.Y.89 (MECCANICA) | 1 ^A | 9 - 1988 | | | | | | |
| 0996 | MILANO M.Y.89 (CARROZZERIA) | 1 ^A | 9 - 1988 | | | | | | |
| 0997 | MILANO 3.0 M.Y.89 (MECCANICA) | 1 ^A | 9 - 1988 | | | | | | |
| 0998 | MILANO 3.0 M.Y.89 (CARROZZERIA) | 1 ^A | 9 - 1988 | | | | | | |
| 0999 | SPIDER 86/87 (MECCANICA) | 7 ^A | 10 - 1988 | 0897 | | | | | |
| 1000 | SPIDER 86/87 (CARROZZERIA) | 7 ^A | 10 - 1988 | 0898 | | | | | |
| 1001 | SPIDER 2.0 M.Y. 85 USA VERSION (MECCANICA) | 9 ^A | 10 - 1988 | 0899 | | | | | |
| 1002 | SPIDER 2.0 M.Y. 85 USA VERSION (CARROZZERIA) | 9 ^A | 10 - 1988 | 0900 | | | | | |
| 1003 | NUOVA GTV 2.0 (MECCANICA) | 19 ^A | 10 - 1988 | 0901 | | | | | |
| 1004 | NUOVA GTV 2.5 (MECCANICA) | 19 ^A | 10 - 1988 | 0902 | | | | | |
| 1005 | NUOVA GTV 2.5 - 2.0 (CARROZZERIA) | 18 ^A | 10 - 1988 | 0903 | | | | | |
| 1006 | GTV 6 2.5 M.Y. 85 USA VERSION (MECCANICA) | 9 ^A | 10 - 1988 | 0904 | | | | | |
| 1007 | GTV 6 2.5 M.Y. 85 USA VERSION (CARROZZERIA) | 8 ^A | 10 - 1988 | 0905 | | | | | |
| 1008 | ALFA 90 (MECCANICA) | 13 ^A | 10 - 1988 | 0923 | | | | | |
| 1009 | ALFA 90 (CARROZZERIA) | 13 ^A | 10 - 1988 | 0924 | | | | | |
| 1010 | ALFA 90 SUPER (MECCANICA) | 7 ^A | 10 - 1988 | 0925 | | | | | |
| 1011 | ALFA 90 SUPER (CARROZZERIA) | 7 ^A | 10 - 1988 | 0926 | | | | | |
| 1012 | MILANO M.Y. 87 USA VERSION (MECCANICA) | 9 ^A | 10 - 1988 | 0929 | | | | | |
| 1013 | MILANO M.Y. 87 USA VERSION (CARROZZERIA) | 9 ^A | 10 - 1988 | 0930 | | | | | |
| 1014 | MILANO 3.0 M.Y. 87 USA VERSION (MECCANICA) | 6 ^A | 10 - 1988 | 0931 | | | | | |
| 1015 | MILANO 3.0 M.Y. 87 USA VERSION (CARROZZERIA) | 6 ^A | 10 - 1988 | 0932 | | | | | |
| 1016 | MILANO M.Y. 88 USA VERSION (MECCANICA) | 3 ^A | 10 - 1988 | 0033 | | | | | |
| 1017 | ALFASUD SPRINT VELOCE (CARROZZERIA) | 13 ^A | 10 - 1988 | 0841 | | | | | |
| 1018 | ALFASUD SPRINT 3 ^{AS} (CARROZZERIA) | 11 ^A | 10 - 1988 | 0842 | | | | | |
| 1021 | 33 1.7 Q.V. (MECCANICA) | 7 ^A | 10 - 1988 | 0936 | | | | | |

| | | | | | |
|---|---|---|--|---|---|
| 1 Numero N. No. Nr. N. | 2 Modello vettura Modèle de voiture Vehicletype Fahrzeugtyp Tipo automovil | 3 Edizione Edition Edition Ausgabe Edicion | 4 Data emissione Date de l'emission Lussing date Ausgabendatum Fecha de emision | 5 Precedente edizione Edition précédente Previous edition Vorherige ausgabe Edicion precedente | ★ Il presente catalogo non avrà piu' successivi aggiornamenti Ce catalogue ne sera plus mis a jour This catalog will be no longer updated Dieser katalog wird keine kurrent haltung mehr haben Este catalogo no tendrá mas puestas al dia |
|---|---|---|--|---|---|

A4

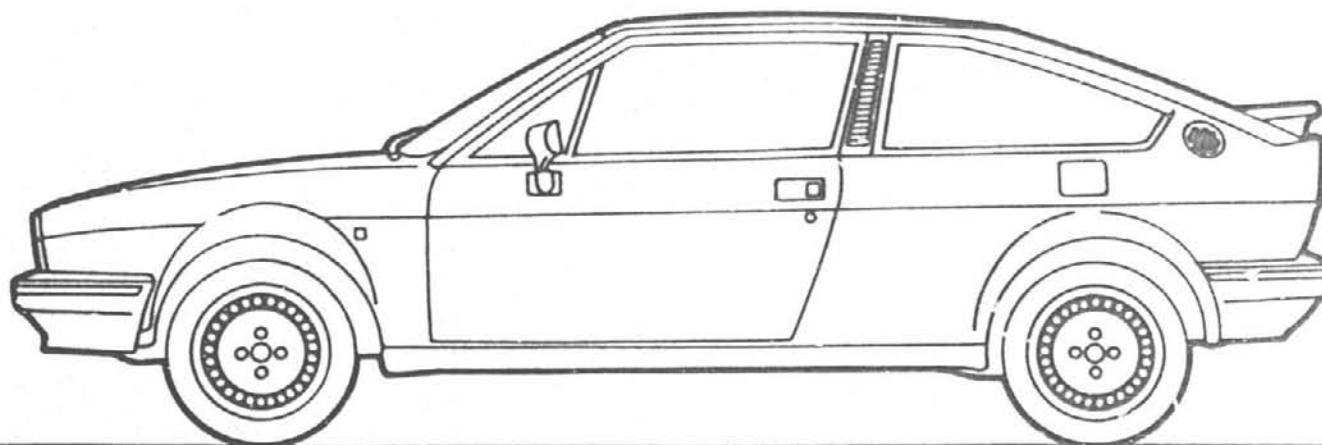

Sprint

Ed. 87

meccanica

| | | |
|---|--|---|
| N.1037 <hr/> 1 - 1989 | CATALOGO PARTI DI RICAMBIO <hr/> IL PRESENTE CATALOGO ANNULLA E SOSTITUISCE IL N.1019 DEL 10 - 1988 | CATALOGUES DE PIÈCES DE RECHANGE <hr/> CATALOGUE N.1019 DU 10 - 1988 ANNULÉ ET REMPLACÉ PAR LE PRÉSENT |
| SPARE PARTS CATALOG <hr/> THIS CATALOG CANCELS AND REPLACES PREVIOUS ONE N.1019 OF 10 - 1988 | ERSATZTEIL KATALOG <hr/> DER ANWESENDE KATALOG ERSETZ DIE NUMMER 1019 VOM 10 - 1988 | CATALOGO DE PIEZAS DE REPUESTO <hr/> EL PRESENTE CATALOGO ANULA Y SOBSTITUYE EL N.1019 DEL 10 - 1988 |

A5

ELENCO DELLE TAVOLE MODIFICATE RISPETTO ALLA PRECEDENTE EDIZIONE
LISTE DES PLANCHES MODIFIEES PAR RAPPORT A L'EDITION PRECEDENTE
MODIFIED TABLES LIST IN RELATION WITH LAST EDITION MICROFICHE
VERZEICHNIS DER BEZUGLICH DER LETZTEN AUSGABE VERANDERTEN TAFELN
ELENCACION LAMINES MODIFICADAS EN RELACION A LA PRECEDENTE EDICION

| COL. | TAV. | COL. | TAV. | COL. | TAV. | COL. | TAV. | COL. | TAV. | COL. | TAV. | COL. | TAV. | COL. | TAV. | COL. | TAV. |
|------|------|------|------|------|------|------|------|------|------|------|------|------|------|------|------|------|------|
| | | | | | | | | | | | | | | | | | |

+ Nuova aggiunta - Nouvelle planche - Added table - Ergänzung - Nueva lámina
- Annullata - Annulé - Deleted - Annulliert - Anulada

A6

c.c. 1700

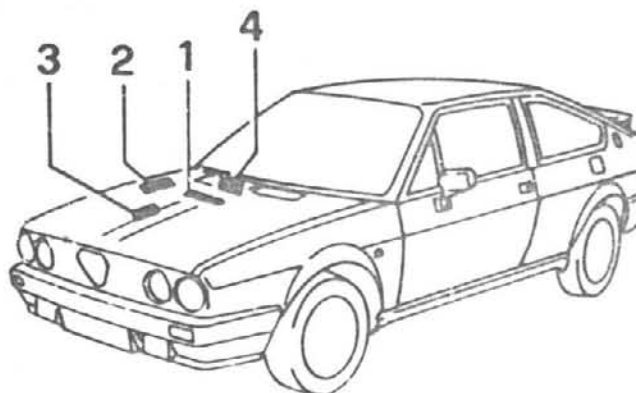

D'ATI D'IDENTIFICAZIONE

IDENTIFICATION

CAR IDENTIFICATION

LAGE VON TYPESCHILD UND FAHRGESTELLNUMMER

IDENTIFICACION DEL VEHICULO

| | 1 TELAIO - CHASSIS - CHASSIS N FAHRGESTELL - Nr BASTRIDOR | 2 TIPO - TYPE TYPE - TYP - TIPO | 3 N. MOTORE - MOTEUR - ENGINE MOTOR - Nr MOTOR | 4 |
|---|---|---|--|---|
| Tipo della vettura Modèle du voiture Vehicle type Fahrzeug - typ Tipo automòvil | | | | |
| 1.7 ● | ☆ZAS902A60 ☆ 05131699 ☆ | Tipo 902A6 — [902.38 g.s. 902.39 ●● | AR30550 ————— 000001 | TARGHETTA CON LE CARATTERISTICHE DELLA VERNICIATURA PLAQUE DES CARACTERISTIQUES DE LA PEINTURE FINISC PLATE SCHILS MIT ANGABEN FUR DIE LACKIERUNG |
| 1.7 - I.E. | ☆ZAS902A60 ☆ 05132615 ☆ | Tipo 902A6A — 90240 ●● ●● | AR30558 ————— A00001 | CHAPITA CON LAS CARACTERISTICAS DE LA PINTURA |

A7

c.c. 1300

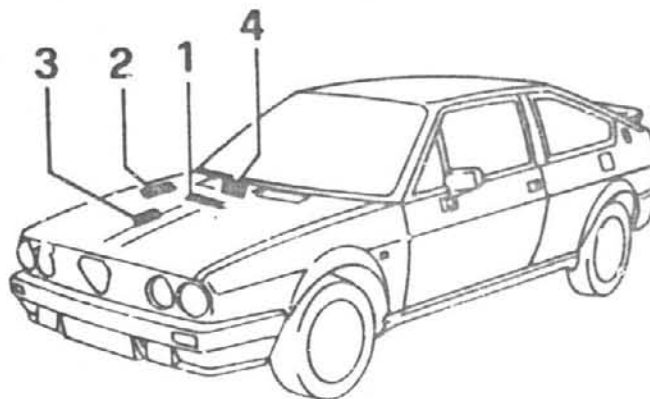

D'ATI D'IDENTIFICAZIONE

IDENTIFICATION

CAR IDENTIFICATION

LAGE VON TYPESCHILD UND FAHRGESTELLNUMMER

IDENTIFICACION DEL VEHICULO

| | 1 | 2 | 3 | 4 |
|---|--|----------------------------------|---|---|
| | TELAIO - CHASSIS - CHASSIS N FAHRGESTELL - Nr BASTRIDOR | TIPO - TYPE TYPE - TYP - TIPO | N. MOTORE - MOTEUR - ENGINE MOTOR - Nr MOTOR | |
| Tipo della vettura Modèle du voiture Vehicle type Fahrzeug - typ Tipo automòvil | | | | |
| 1.3 | ☆ ZAS902A40 ☆ 05001001 ☆ | tipo 902A4B | AS 30168 0000001 | <p>TARGHETTA CON LE CARATTERISTICHE DELLA VERNICIATURA</p> <p>PLAQUE DES CARACTERISTIQUES DE LA PEINTURE</p> <p>FINISC PLATE</p> <p>SCHILDS MIT ANGABEN FÜR DIE LACKIERUNG</p> <p>CHAPITA CON LAS CARACTERISTICAS DE LA PINTURA</p> |

PREMESSA

Il presente catalogo, realizzato con soie figure è costituito da:

- 1) Un indice grafico generale (tavola A) suddiviso in gruppi di argomenti individuati secondo le lettere dell'alfabeto.
- 2) Una serie di indici parziali per ciascun gruppo di tavole individuate dalle lettere dell'alfabeto dell'indice generale.
- 3) Le tavole del catalogo secondo gli indici parziali. Simboli codificati forniscono informazioni complementari nelle ordinazioni dei particolari (progressivi, introduzione, validità, ecc.). Il significato dei simboli e delle espressioni codificate è riportato alla pag. A9.

Alla fine del catalogo è inserito l'indice numerico dei categorici con le relative quantità e numero tavola. All'inizio del suddetto indice sono riportati tutti i movimenti effettuati rispetto al precedente aggiornamento. Inoltre è riportato (vedi tavola T17) un indice di comparazione tra codice tavola e sottogruppo di appartenenza.

VORAUSSETZUNG

Der vorliegende, nur mit Abbildungen verwirklichte Katalog besteht aus:

- 1) Einem allgemeinen graphischen Verzeichnis (Tafel A) eingeteilt nach Stoffgruppen in alphabetischer Reihenfolge.
- 2) Einer Reihe von Teilverzeichnissen für jede einzelne Tafelgruppe gemäss den Buchstaben des allgemeinen Verzeichnisses.
- 3) Katalogstafeln gemäss den Teilverzeichnissen. Kodifizierte Symbole geben zusätzliche Auskunft bei den Bestellungen der Einzelteile (Einbauordnung, Gültigkeit, usw.). Die Bedeutung der Symbole und der kodifizierten Ausdrücke ist auf Seite A10 wiedergegeben.

Am Ende des Katalogs ist das numerische Verzeichnis der Kat. nr. mit der entsprechenden Menge und der Tafelnummer beigefügt. Am anfang des o.g. index sind alle bewegungen in vermachtnis zu der vormerigen kurrent hactung, ermacten. Ausserdem ist eine Vergleichsverzeichnis (siehe Tafel T17) zwischen Tafelkodex und Untergruppenzugehörigkeit angegeben.

USO DEL CATALOGO

Ricerca del numero di ordinazione di un pezzo conoscendone la funzione:

- 1) Cercare nell'indice grafico generale (tavola A) la lettera di appartenenza del gruppo interessato.
- 2) Individuata la lettera cercare nel corrispondente indice parziale la tavola interessata.
- 3) Determinata la tavola individuare il numero del particolare tenendo conto degli eventuali simboli o codificazioni che specificano norme e validità.

Ricerca di un pezzo tramite un numero di ordinazione:

- 1) Cercare nell'indice numerico (da tavola S2) il numero del pezzo e rilevare il codice della tavola.
- 2) Cercare nell'indice di comparazione tra codice tavola e lettera di appartenenza del sottogruppo (tavola T17) la lettera corrispondente alla tavola interessata.
- 3) Consultare la tavola e rilevare il pezzo di cui si conosce il numero di ordinazione.

GEBRAUCH DES KATALOGS

Nachschlag der Bestellungsnummer eines Teiles, dessen Funktion man kennt.

- 1) Im allgemeinen graphischen Verzeichnis (Tafel A) den Zugehörigkeitsbuchstaben der betreffen Gruppe suchen.
- 2) Sobald man den Buchstaben gefunden hat, im betreffenden Teilverzeichnis die entsprechende Tafel suchen.
- 3) Auf der Tafel die Nummer des Einzelteiles feststellen mit Beachtung der eventuellen Symbole oder Kodifizierungen, die Bestimmungen und Gültigkeit angeben.

Nachschlag eines Teiles mit Hilfe der Bestellungsnummer:

- 1) Im numerischen Verzeichnis (ab abbildung S2) die Nummer des Stückes suchen und den Kodex der Tafel entnehmen.
- 2) Im Vergleichsverzeichnis zwischen Tafelkodex und Untergruppenzugehörigkeit (Tafel T17) den Buchstaben der Betreffenden Tafel suchen.
- 3) Die Tafel Beraten und das Stück aufsuchen, dessen Bestellungsnummer man kennt.

| | | |
|----------------------------------|---|--|
| D... Tav. 32.11 | = | tav. 32.11 contenente particolari postmodifica (D) |
| F... Tav. 32.11/1 | = | tav. 32.11/1 contenente particolari premodifica (F) |
| F... + N. ordinazione | = | particolari premodifica (F) |
| D... + N. ordinazione | = | particolari postmodifica (D) |
| F... /... F... - N1 - N2 - ecc. | } | particolari premodifica (F) o postmodifica (D) con indicazione di impanglio (/...), i cui particolari contrassegnati con lo stesso numero di modifica sono da ricercare nei fotogrammi indicati con (N1 - N2 - ecc.) |
| D... /... D... - N1 - N2 - ecc. | | |
| T. M. 2050227 | = | la tavola (od il particolare) vale fino al veicolo con numero di telaio T. 2050227 se il numero è preceduto dalla T. oppure con numero motore M. 2050227 se il numero è preceduto dalla M. |
| T. M. 2050228 | = | la tavola (od il particolare) vale dal veicolo con numero di telaio T. 2050228 se il numero è preceduto dalla T. oppure con numero motore M. 2050228 se il numero è preceduto dalla M. |
| 5 - 1974 | = | data che precede l'applicazione della modifica |
| 6 - 1974 | = | data di applicazione della modifica |
| D. - C4 - ecc. | = | indicazione dei fotogrammi |
| /... | = | impangliare con... |
| A + B... + N. ordinazione | = | confezione ricambi composta dai particolari A + B ecc. illustrati nella tavola |
| 510654 531234 } — | = | in alternativa |
| 543765 | = | parte specifica di una versione; consultare in calce alla tavola ed il fotogramma A10 per la validità |
| 153432 + 0,2 | = | particolare con indicazione della maggiorazione di 0,2 mm |
| 101440 sp. 1,25 | = | particolare con indicazione dello spessore di 1,25 mm |
| 107635 gr. 50 | = | particolare con indicazione del peso di 50 gr. |
| 543873 s. 543874 d. | = | particolare sinistro particolare destro } — rispetto al senso di marcia del veicolo |
| 518765 Ø 6,5 | = | particolare avente diametro di 6,5 mm |
| G.S. - g.s. | = | particolare o tavola per veicolo con guida sinistra |
| G.D. - g.d. | = | particolare o tavola per veicolo con guida destra |
| N. | = | numero ordinazione |
| TAV. | = | tavola |
| Qt. | = | quantità |
| COL. | = | colonna |
| | = | i particolari sono contenuti in due o più tavole |
| 564786 | = | parte sostituita o eliminata |
| TAV. F5 - K2 - ecc. | = | parte richiamata nella tavola F5 - K2 - ecc. |
| 00 | = | fornito a metri oppure a richiesta (riportato nella colonna della quantità) |

| | | |
|-----------|---|-----------------------------|
| CZ | = | carta da zucchero |
| BR | = | bronzo |
| RS | = | rosa |
| BI | = | bianco |
| GI | = | giallo |
| RO | = | rosso |
| VE | = | verde |
| NE | = | nero |
| BL | = | blu |
| MA | = | marrone |
| AZ | = | azzurro |
| AR | = | arancione |
| CR | = | crema |
| VI | = | viola |
| GR | = | grigio |
| CA | = | cambio automatico |
| TA | = | tetto apribile |
| | = | veicoli condizionate |
| T | = | dopo esaurimento fornire... |
| | = | fornito in centimetri |
| W | = | Watt |
| f | = | suono acuto |
| J | = | suono grave |
| | = | aspirazione |
| | = | scarico |
| | = | a richiesta |
| 1 | = | 1° velocità |
| 2 | = | 2° velocità |
| 3 | = | 3° velocità |
| 4 | = | 4° velocità |
| 5 | = | 5° velocità |
| R | = | retromarcia |
| A | = | anteriore |
| P | = | posteriore |
| E | = | esterno |
| I | = | interno |
| ↑ | = | superiore |
| ↓ | = | inferiore |
| V | = | verticale |

| | | |
|--------------------------------|---|--|
| D... Tav. 32.11 | = | tafel 32.11 enthält teile abgeänderte teile |
| F... Tav. 32.11/1 | = | tafel 32.11/1 enthält ungeänderte teile |
| F... + Best. Nr. | = | teile vor Änderung (F) |
| D... + Best. Nr. | = | teile nach Änderung (D) |
| F... /... F... - N1 - N2 - usw | } | ungeänderte (F) und abgeänderte (D) teile mit kombinationsangabe (/...), wobei teile mit der gleichen änderungszahl (1584) in den mit (N1 - N2 - usw) bezeichneten bildern zu suchen sind. |
| D... /... D... - N1 - N2 - usw | | |
| T. M. 2050227 | = | tafel bzw. teil gilt bis fahrzeug mit fahrgestell-nr. 2050227, wenn der zahl ein T vorausgeht, oder bis motor-nr. M 2050227, wenn ein M vorausgeht |
| T. M. 2050228 | = | tafel bzw. teil gilt ab fahrzeug mit fahrgestell-nr. T 2050228, wenn der zahl ein T vorausgeht, oder ab motor-nr. 2050228, wenn ein M vorausgeht |
| 5 - 1974 | = | datum vor der änderung |
| 6 - 1974 | = | datum ab welchem die änderung einsetzt |
| D. - C4 - usw | = | angabe der bilder |
| /... | = | in verbindung mit... |
| A + B... + Best. Nr. | = | ersatzteilkorrektur mit den in der tafel abgebildeten teilen A + B usw |
| 510654 531234 | } | in alternative |
| 543765 | | |
| 153432 + 0.2 | = | spezielles teil einer ausführung; gültigkeit unten in tabelle u. bild A11 nachprüfen |
| 101440 sp. 1.25 | = | teil mit angabe einer mehrlänge von 0.2 mm |
| 107335 gr. 50 | = | teil mit dickenangabe von 1.25 mm |
| 543873 s. | = | teil mit gewichtsangabe von 50 gr |
| 543874 d. | = | linkes teil |
| 518765 Ø 6.5 | = | rechtes teil |
| G.S. - g.s. | } | gegenüber der fahrrihtung des fahrzeugs |
| G.D. - g.d. | | |
| N. | = | teil mit 6.5 mm durchmesser |
| TAV. | = | teil oder tafel für fahrzeug mit linkslenker |
| Qt | = | teil oder tafel für fahrzeug mit rechtslenker |
| COL | = | best. nr. |
| | = | tafel |
| 564786 | = | stückzahl |
| TAV. F5 - K2 - ecc. | = | spalte |
| 00 | = | die teile sind zwei oder mehr tafeln aufgezeichnet |
| | = | ersetzt |
| | = | teil auch in tafel F5 - K2 usw. |
| | = | wird meterweise over auf anfrage geliefert in der stückzahl-spalte angegeben |

Falls nicht anders angegeben sind alle Messen in Millimeter

| | | |
|-----------|---|---------------------------------|
| CZ | = | grau blau |
| BR | = | bronze |
| RS | = | rosa |
| BI | = | weiss |
| GI | = | gelb |
| RO | = | rot |
| VE | = | grün |
| NE | = | schwarz |
| BL | = | blau |
| MA | = | braun |
| AZ | = | hellblau |
| AR | = | orange |
| CR | = | creme |
| VI | = | lila |
| GR | = | grau |
| CA | = | automatisches getriebe |
| TA | = | schiebendach |
| | = | autos mit klimaanlage |
| | = | falls vergriffen, lieferung von |
| | = | in zentimeter |
| W | = | Watt |
| f | = | heller ton |
| d | = | dunkler ton |
| | = | entlüftung |
| | = | ablass |
| | = | auf wunsch |
| 1 | = | 1 gang |
| 2 | = | 2 gang |
| 3 | = | ? gang |
| 4 | = | 4 gang |
| 5 | = | 5 gang |
| R | = | rückwärtsgang |
| A | = | vorne |
| P | = | hinten |
| E | = | aussen |
| I | = | innen |
| ↑ | = | oben |
| ↓ | = | unten |
| V | = | lackiert |

A11VALIDITÀ
GÜLTIGKEIT

| | Varianti per: | Equipement pour: | Variants: | Abgeleitete Typen: | Variaciones para: |
|------------|---------------|------------------|---------------|--------------------|-------------------|
| A | Austria | Autriche | Austria | Österreich | Austria |
| B | Belgio | Belgique | Belgium | Belgien | Belgica |
| DK | Danimarca | Danemark | Denmark | Dänemark | Dinamarca |
| F | Francia | France | France | Frankreich | Francia |
| SF | Finlandia | Finlande | Finland | Finnland | Finlandia |
| D | Germania | Allemagne | Germany | Deutschland | Alemania |
| GB | Gran Bretagna | Grande Bretagne | Great Britain | England | Inghilterra |
| YU | Yugoslavia | Yugoslavie | Yugoslavia | Jugoslavien | Yugoslavia |
| N | Norvegia | Norvège | Norway | Norwegen | Norvegia |
| NL | Olanda | Hollande | Holland | Holland | Holanda |
| S | Svezia | Suède | Sweden | Schweden | Svezia |
| CH | Svizzera | Suisse | Switzerland | Schweiz | Suiza |
| J | Giappone | Japon | Japan | Japan | Japón |
| AUS | Australia | Australie | Australia | Australien | Australia |
| ZA | Sud Africa | Afrique du Sud | South Africa | Südafrika | Sud Africa |
| BR | Brasile | Bésil | Brazil | Brasilien | Brasil |

SPRINT 87
MECCANICA

1-1288

C

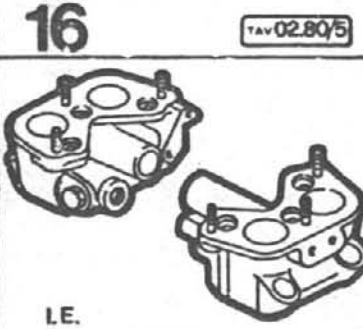
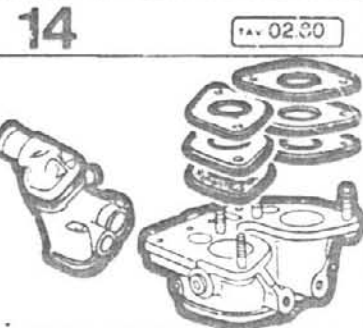
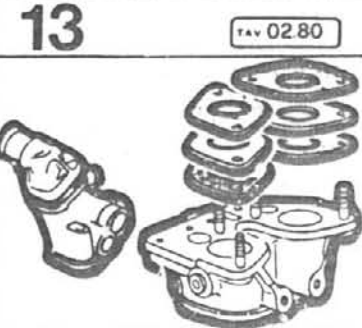
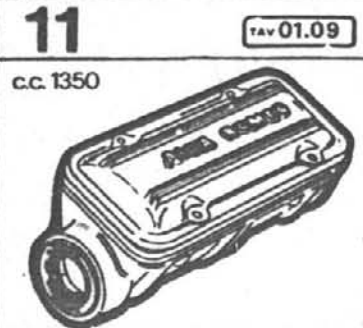
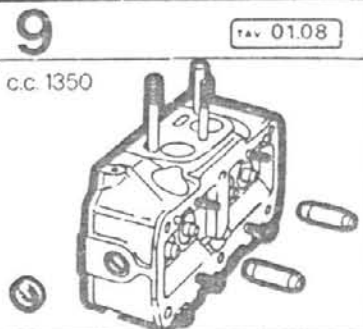
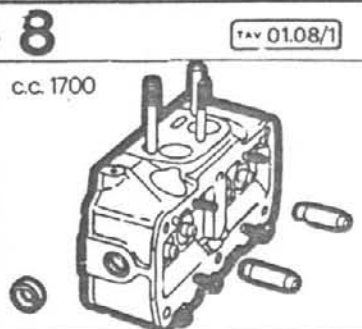
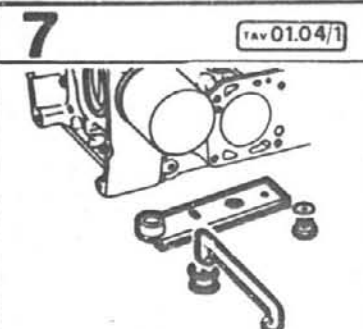
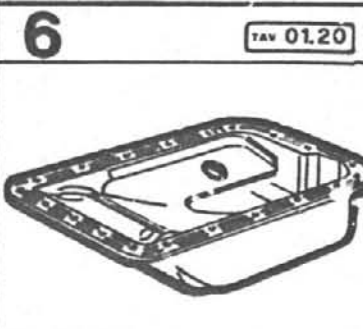
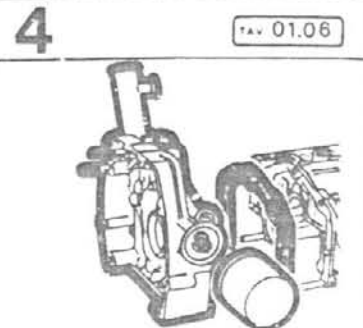
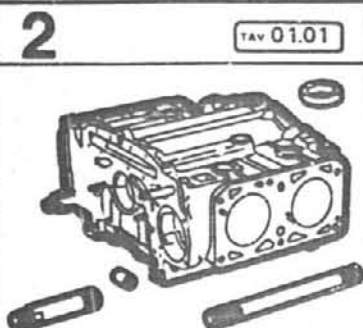
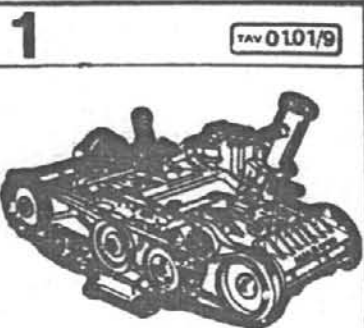

I.E.

I.E.

C₁

SPRINT
Ed. 87
Meccanica

1-1989

TAV. 01.01/9

c.c. 32

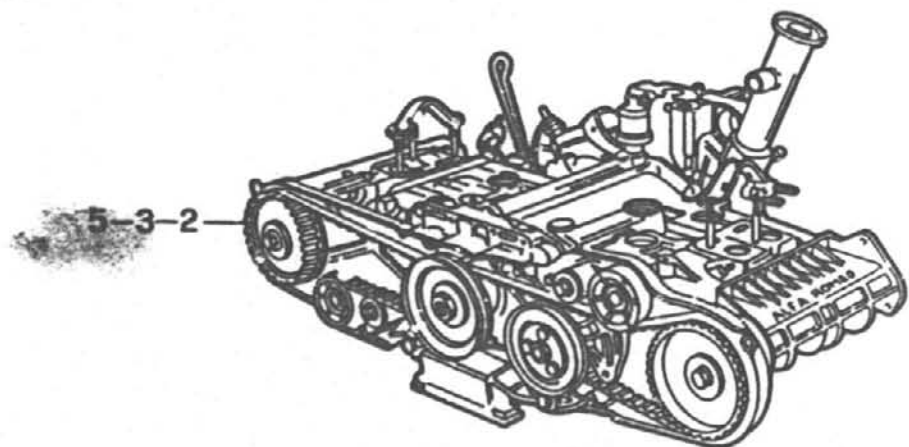
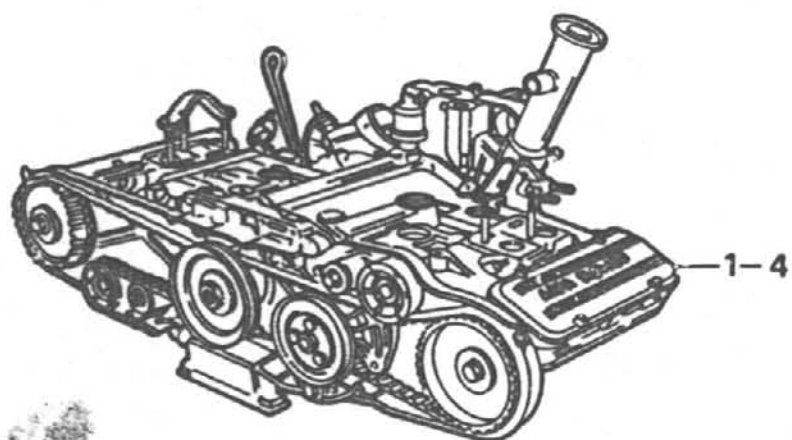

| pos. | TEILNUMMER | ref. | mg. benennung |
|------|-------------|------|---------------|
| 1 | 00607 44354 | ▲ | 1 MOTOR |
| 2 | 00607 44356 | ● | 1 MOTOR |
| 3 | 00607 44358 | ■ | 1 MOTOR |
| 4 | 00607 44361 | □ | 1 MOTOR |
| 5 | 00607 44363 | □ | 1 MOTOR |

▲ c.c. 1.3

● c.c. 1.7

■ I.E.

□ c.c. 1.395 R.O.N.

□ c.c. 1.795 R.O.N.

C₂

SPRINT
Ed. 87
Meccanica

1-1989

TAV. 01.01

c.c. 32

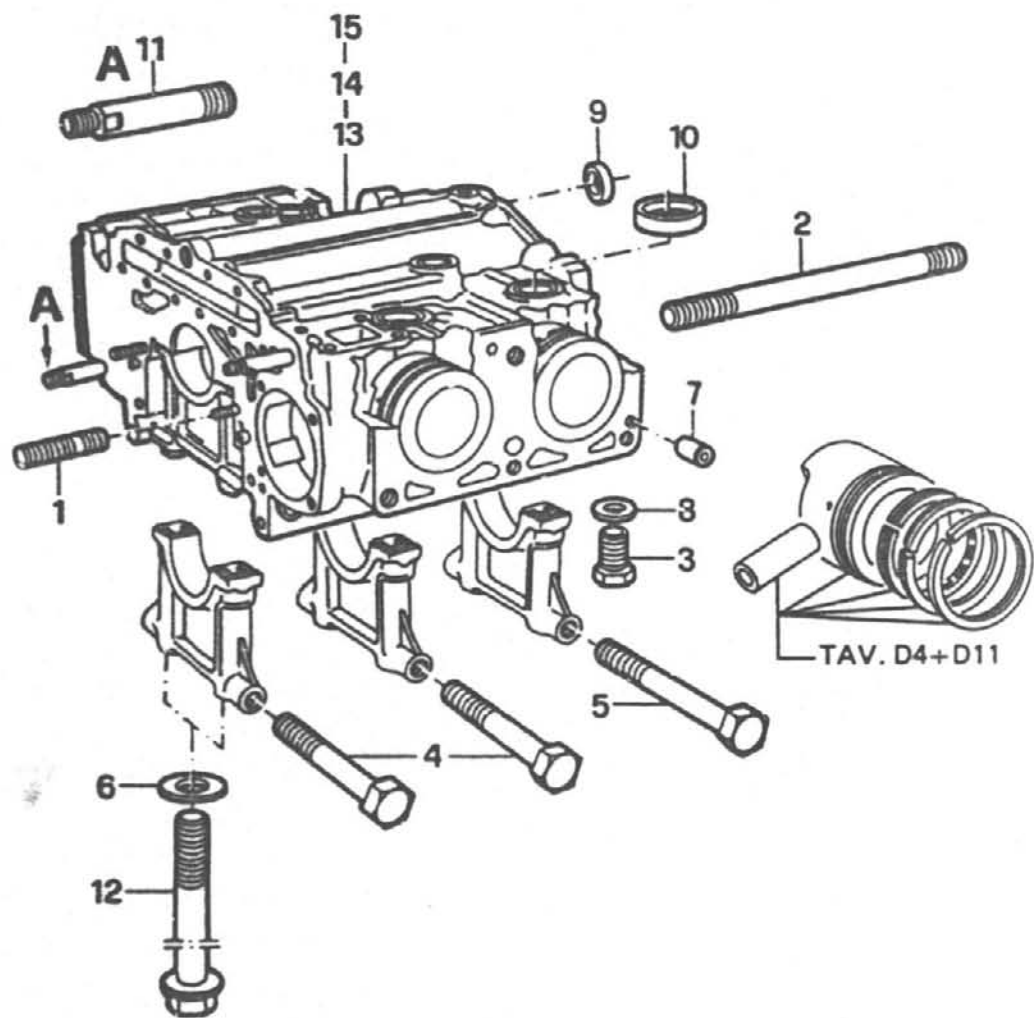

| pos. | TEILNUMMER | ref. | mg. | benennung |
|------|-------------|------|-----|----------------|
| 1 | 02100 09064 | | 2 | STEBOLZEN |
| 2 | 02100 08130 | | 2 | STEBOLZEN |
| 3 | 00159 70111 | | 2 | SCHRAUBE |
| 4 | 00113 43721 | | 4 | SCHRAUBE |
| 5 | 00159 71421 | | 2 | SCHRAUBE |
| 6 | 00135 79760 | | 6 | SCHEIBE |
| 7 | 00605 43581 | | 8 | PASSTIFT |
| 8 | 00102 84450 | | 2 | DICHTUNG |
| 9 | 00143 28401 | | 3 | STOPFEN |
| 10 | 00143 29801 | | 10 | STOPFEN |
| 11 | 00605 02890 | | 2 | BOLZEN |
| 12 | 00605 03029 | | 6 | SCHRAUBE |
| 13 | 00607 50814 | ● □ | 1 | KURBELGEHAEUSE |
| 14 | 00607 50645 | ▲ | 1 | KURBELGEHAEUSE |
| 15 | 00607 50877 | □ | 1 | KURBELGEHAEUSE |

- c.c. 1.7
- c.c. 1.7 95 R.O.N.
- ▲ c.c. 1.3
- c.c. 1.3 95 R.O.N.

C₃

SPRINT
Ed. 87
Meccanica
1-1989

TAV. 01.04

c.c. 32

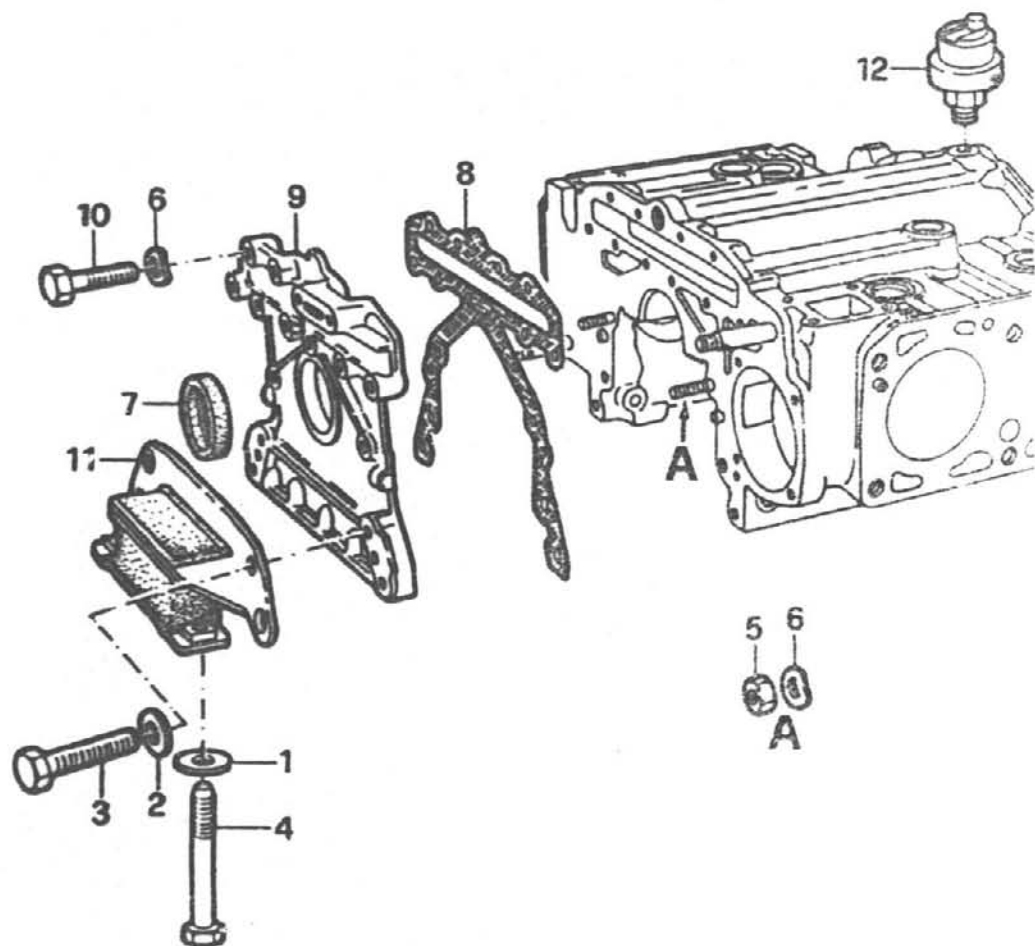

| pos. | TEILNUMMER | ref. | mg. benennung |
|------|-------------------|------|------------------|
| 1 | 02100 01435 00 00 | | 2 SCHEIBE |
| 2 | 02100 81437 00 00 | | 4 SCHEIBE |
| 3 | 00113 07021 | | 4 SCHRAUBE |
| 4 | 00161 36921 | | 2 SCHRAUBE |
| 5 | 00161 00811 | | 2 MUTTER |
| 6 | 00126 01379 | | 9 SCHEIBE |
| 7 | 00605 02891 | | 1 DICHRING |
| 8 | 00605 03078 | | 1 DICHTUNG |
| 9 | 00605 03093 | | 1 DECKEL |
| 10 | 00605 04832 | | 7 SCHRAUBE |
| 11 | 00605 01321 | | 1 ZWISCHENSTUECK |
| 12 | 00605 372+6 | | 1 GEBER |

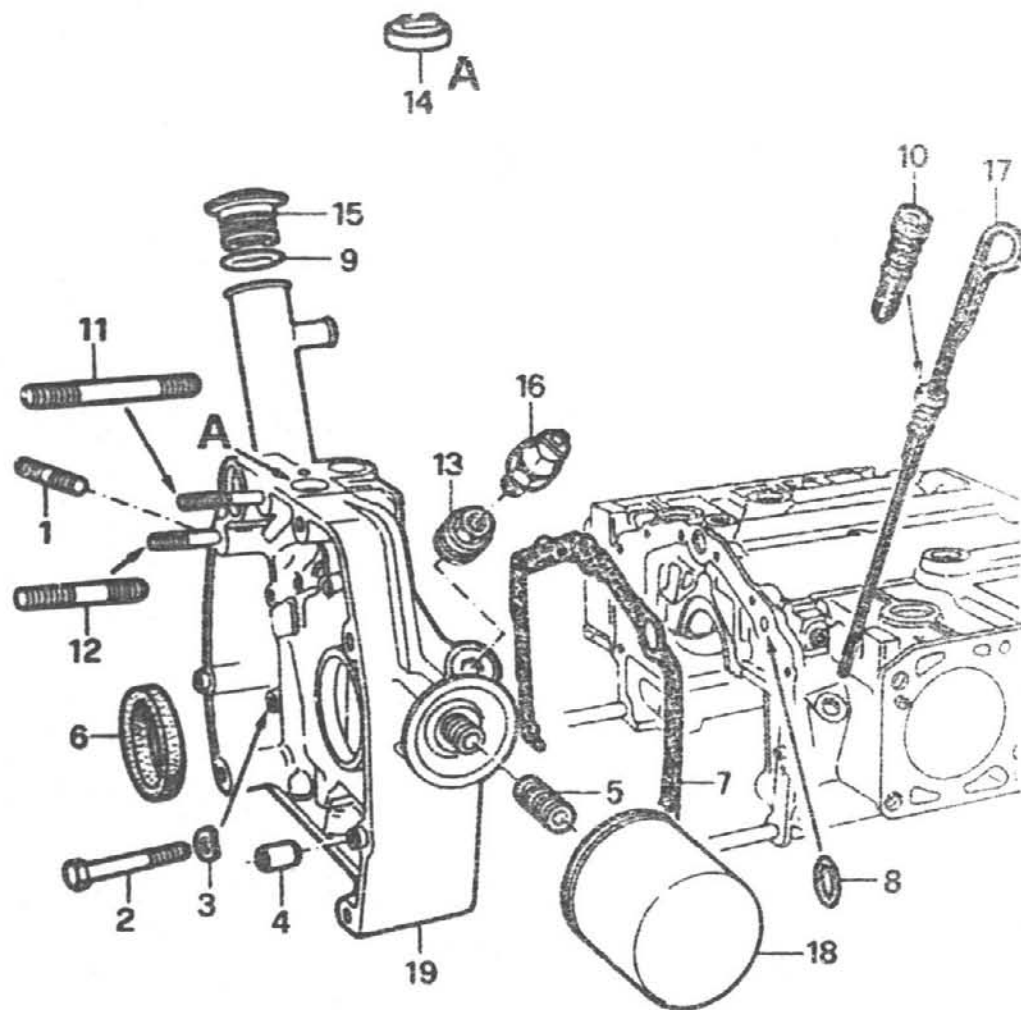

| pos. | TEILNUMMER | ref. | mg. benennung |
|------|-------------|------|---------------|
| 1 | 02100 09428 | | 2 STEHBOLZEN |
| 2 | 02100 20196 | | 8 SCHRAUBE |
| 3 | 00126 01370 | | 8 SCHEIBE |
| 4 | 00605 26036 | | 2 PASSTIFT |
| 5 | 00605 02892 | | 1 VERTEILER |
| 6 | 00605 02893 | | 1 DICHRING |
| 7 | 00605 02953 | | 1 DICHTUNG |
| 8 | 00605 02954 | | 1 DICHRING |
| 9 | 00605 02962 | | 1 DICHTUNG |
| 10 | 00605 02963 | | 1 DICHTUNG |
| 11 | 00605 02994 | | 1 STEHBOLZEN |
| 12 | 00605 02995 | | 1 STEHBOLZEN |
| 13 | 00605 03034 | | 1 VERTEILER |
| 14 | 00605 03155 | | 1 DECKEL |
| 15 | 00605 03297 | | 1 STOPFEN |
| 16 | 00605 04190 | | 1 GEBER |
| 17 | 00605 04193 | | 1 STANGE |
| 18 | 00605 04284 | | 1 OELFILTER |
| 19 | 00966 09970 | | 1 DECKEL |

C5

SPRINT
Ed. 87
Meccanica

1-1980

I.E.

TAV. 01.06/5

c.c. 32

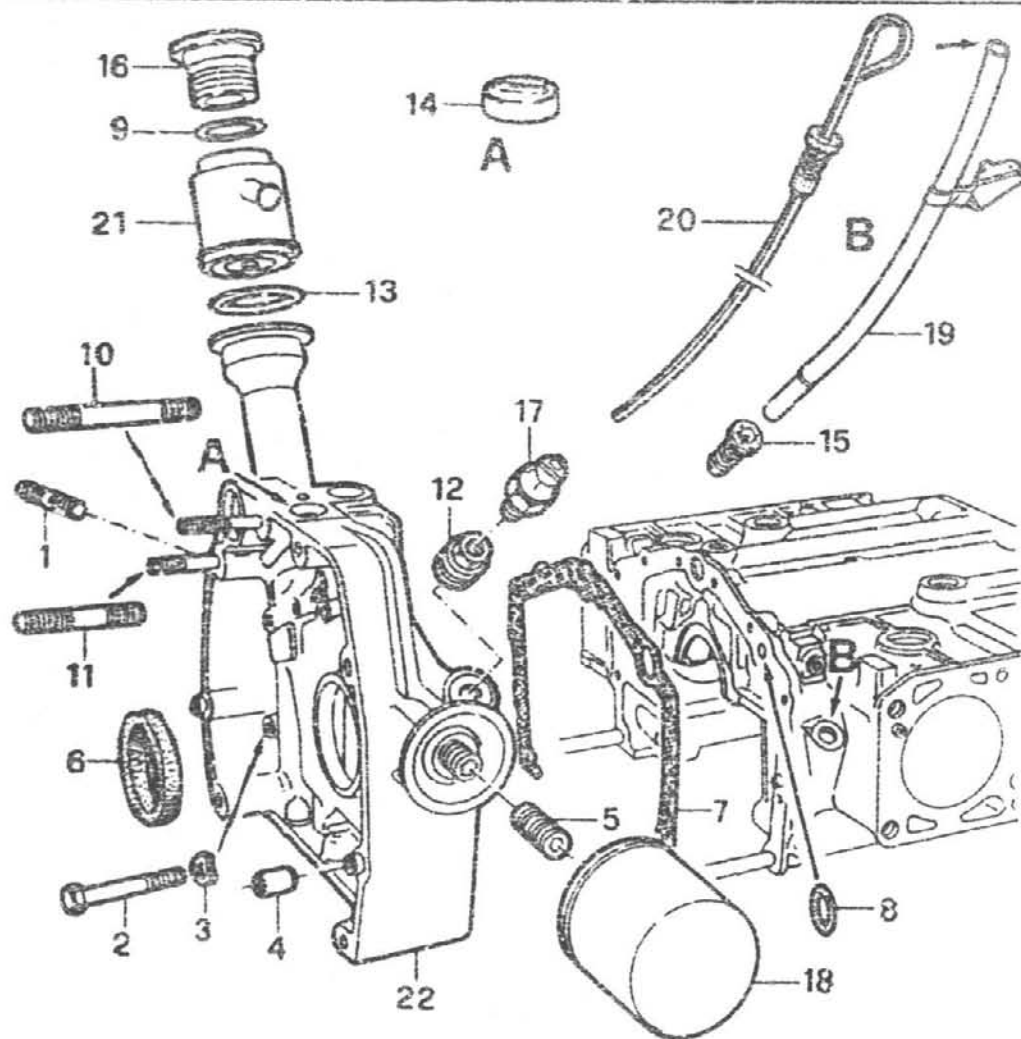

| pos. | TEILNUMMER | ref. | mg. benennung |
|------|-------------|------|-----------------|
| 1 | 02100 09428 | | 2 STEHBOLZEN |
| 2 | 02100 20196 | | 8 SCHRAUBE |
| 3 | 00126 01370 | | 8 SCHEIBE |
| 4 | 00605 26036 | | 2 PASSTIFT |
| 5 | 00605 02892 | | 1 VERTEILER |
| 6 | 00605 02893 | | 1 DICHRING |
| 7 | 00605 02953 | | 1 DICHTUNG |
| 8 | 00605 02954 | | 1 DICHRING |
| 9 | 00605 02962 | | 1 DICHTUNG |
| 10 | 00605 02994 | | 1 STEHBOLZEN |
| 11 | 00605 02995 | | 1 STEHBOLZEN |
| 12 | 00605 03034 | | 1 VERTEILER |
| 13 | 00605 17440 | | 1 C-GUMMIRING |
| 14 | 00605 03155 | | 1 DECKEL |
| 15 | 00605 25193 | | 1 KOPFSTUETZE |
| 16 | 00605 25196 | | 1 STOPFEN |
| 17 | 00605 04190 | | 1 GEBER |
| 18 | 00605 04284 | | 1 OELFILTER |
| 19 | 00605 38401 | | 1 ROHR |
| 20 | 00605 38469 | | 1 STANGE |
| 21 | 00605 38512 | | 1 OELABSCHIEDER |
| 22 | 00966 09974 | | 1 DECKEL |

C6

SPRINT
Ed. 87
Meccanica

1-1989

TAV. 01.20

c.c. 32

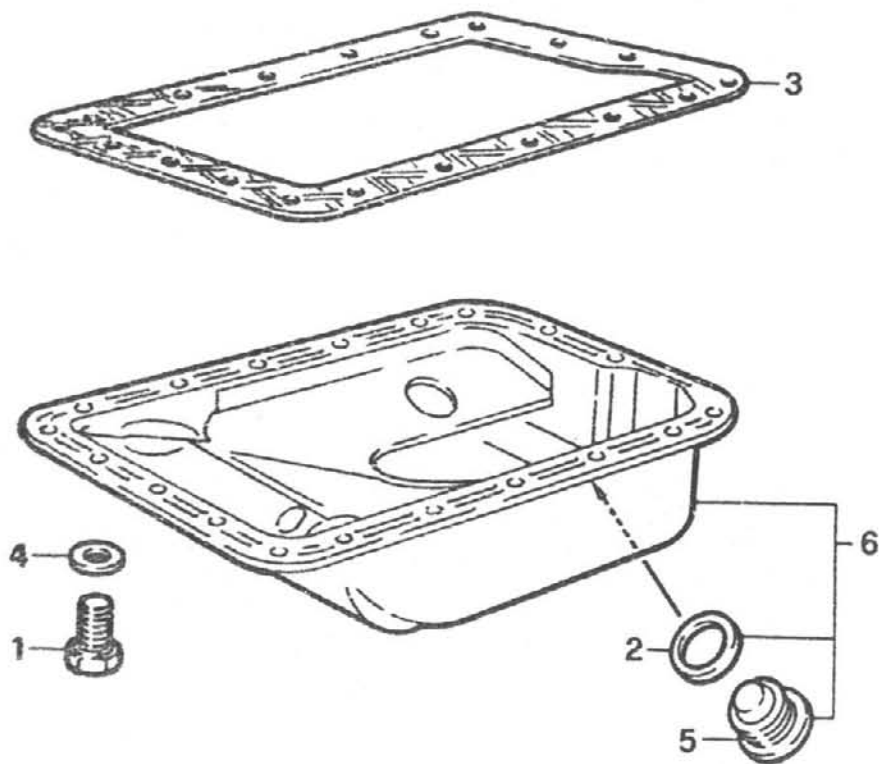

| pos. | TEILNUMMER | ref. | mg. | benennung |
|------|-------------|------|-----|-----------|
| 1 | 00109 C2121 | | 20 | SCHRAUBE |
| 2 | 00102 63450 | | 1 | DICHTUNG |
| 3 | 00605 15493 | | 1 | DICHTUNG |
| 4 | 00605 02533 | | 20 | SCHEIBE |
| 5 | 00607 48201 | | 1 | STOPFEN |
| 6 | 00605 15408 | | 1 | OELWANNE |

C7

SPRINT
Ed. 87
Meccanica
1-1989

TAV. 01.04/1

c.c. 32

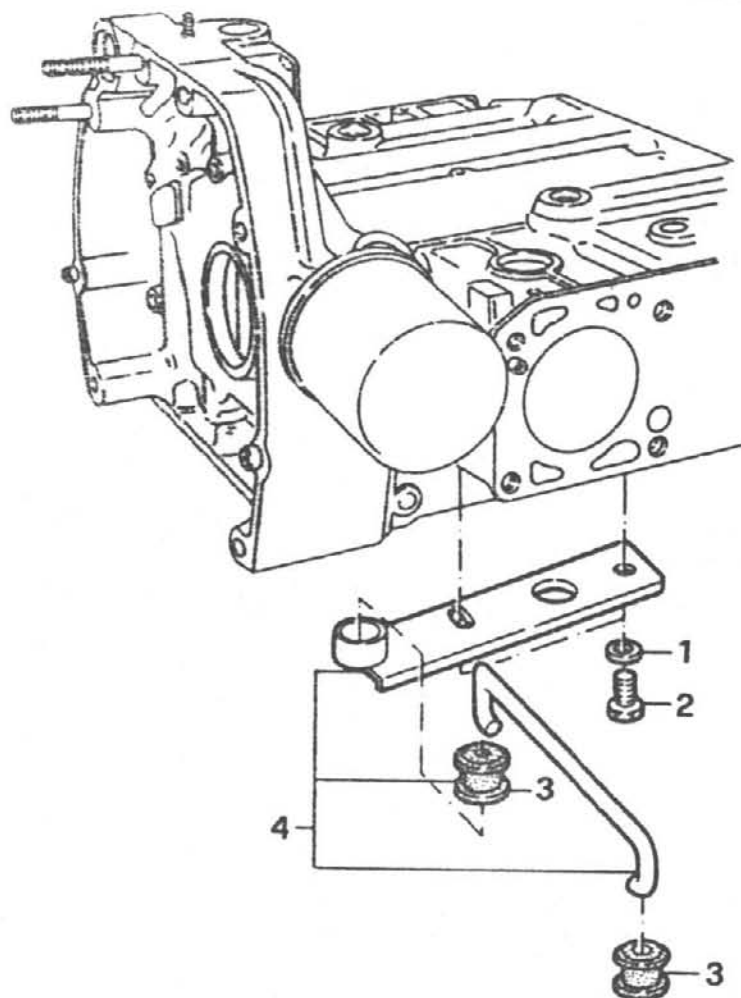

| pos. | TEILNUMMER | ref. | mg. benennung |
|------|-------------------|------|------------------|
| 1 | 02100 61437 00 00 | | 2 SCHEIBE |
| 2 | 00607 09777 | | 2 SCHRAUBE |
| 3 | 00605 01317 | | 2 ZWISCHENSTUECK |
| 4 | 00605 01326 | | 1 STANGE |

C₈

SPRINT
Ed. 87
Meccanica

1-1989

c.c. 1.7

TAV. 01.08/1

c.c. 32

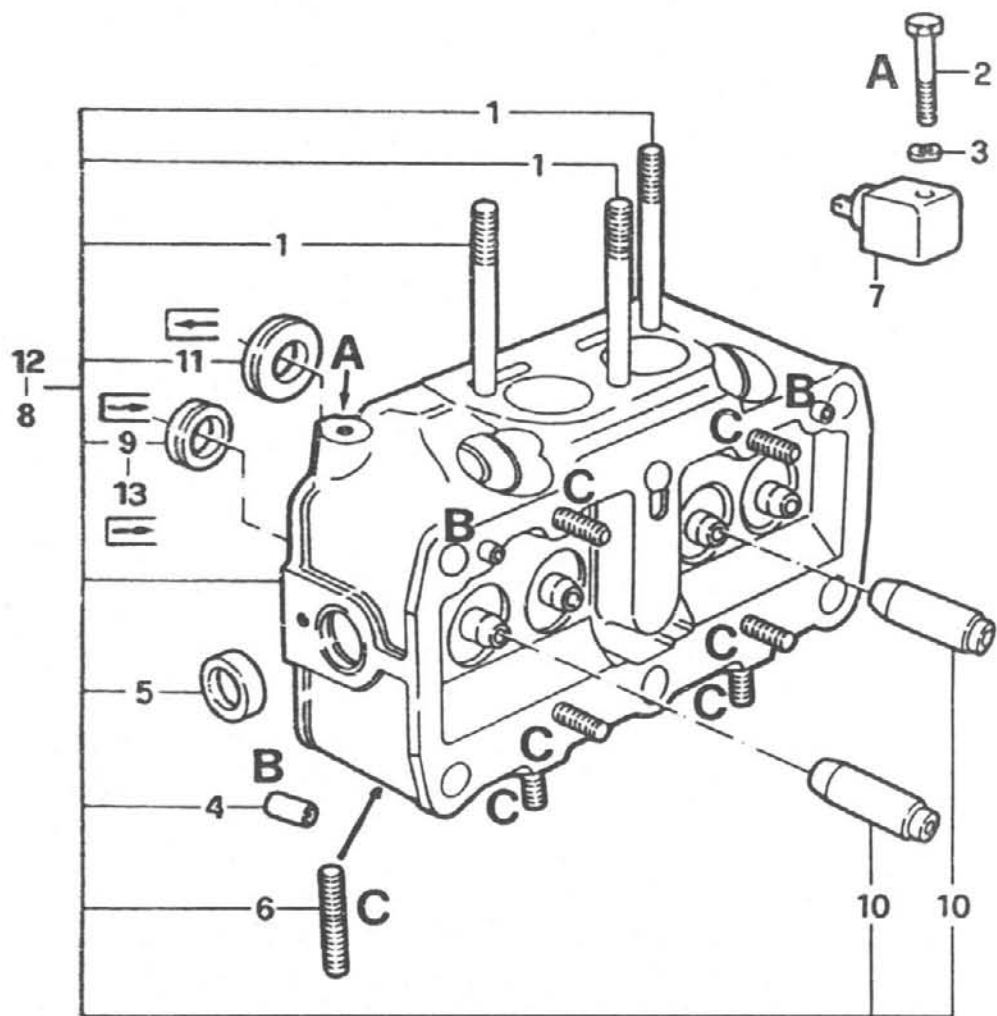

| pos. | TEILNUMMER | ref. | mg. | benennung |
|------|-------------------|------|-----|----------------|
| 1 | 02100 09434 | | 1 | STEBBOLZEN |
| 2 | 00109 02721 | | 1 | SCHRAUBE |
| 3 | 00126 01279 | | 1 | SCHEIBE |
| 4 | 00605 43581 | | 4 | PASSTIFT |
| 5 | 02365 36108 00 00 | | 4 | STOPFEN |
| 6 | 00605 02996 | | 8 | STEBBOLZEN |
| 7 | 00605 04375 | | 1 | GEBER |
| 8 | 00605 37671 | | 2 | ZYLINDERKOPF |
| 9 | 00607 49280 | | 4 | VENTILSITZ |
| 10 | 00607 50222 | | 8 | VENTILFUEHRUNG |
| 11 | 00966 09975 | | 4 | VENTILSITZ |
| 12 | 00605 14905 | ■ | 2 | ZYLINDERKOPF |
| 13 | 00607 55048 | ■ | 4 | VENTILSITZ |

C₉

SPRINT
Ed. 87
Meccanica
1-1989

c.c. 1.3

TAV. 01.08

c.c. 32

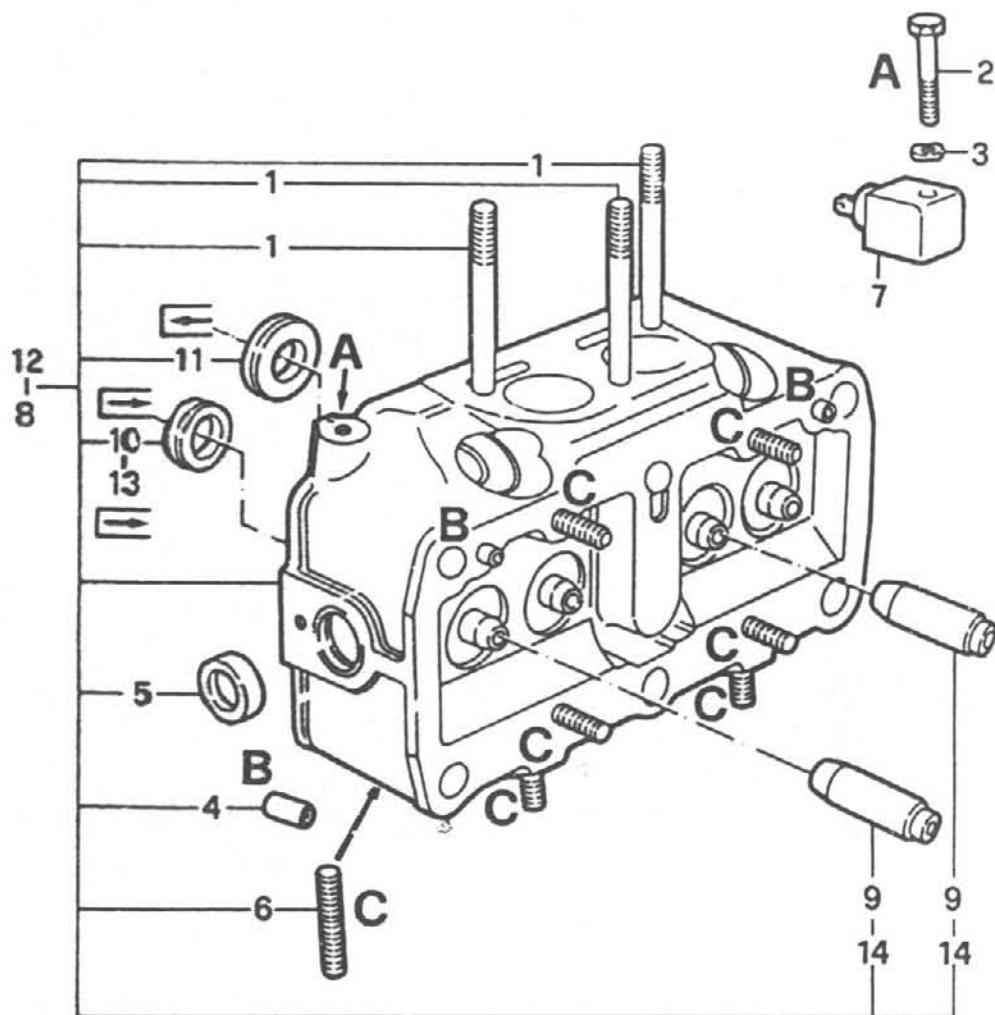

| pos. | TEILNUMMER | ref. | mg. | benennung |
|------|-------------------|------|-----|----------------|
| 1 | 02100 05434 | | 3 | STEBOLZEN |
| 2 | 00109 02721 | | 1 | SCHRAUBE |
| 3 | 00126 01279 | | 1 | SCHEIBE |
| 4 | 00605 43581 | | 4 | PASSTIFT |
| 5 | 02365 36108 00 00 | | 4 | STOPFEN |
| 6 | 00605 02996 | | 8 | STEBOLZEN |
| 7 | 00605 04375 | | 1 | GEBER |
| 8 | 00605 37743 | | 2 | ZYLINDERKOPF |
| 9 | 00607 48209 | | 8 | VENTILFUEHRUNG |
| 10 | 00607 49280 | | 4 | VENTILSITZ |
| 11 | 00966 09975 | | 4 | VENTILSITZ |
| 12 | 00605 04755 | ■ | 2 | ZYLINDERKOPF |
| 13 | 00607 55048 | ■ | 4 | VENTILSITZ |
| 14 | 00607 50222 | ■ | 8 | VENTILFUEHRUNG |

C11

SPRINT
Ed. 87
Meccanica

1-1989

c.c. 1.3

TAV. 01.09

c.c. 32

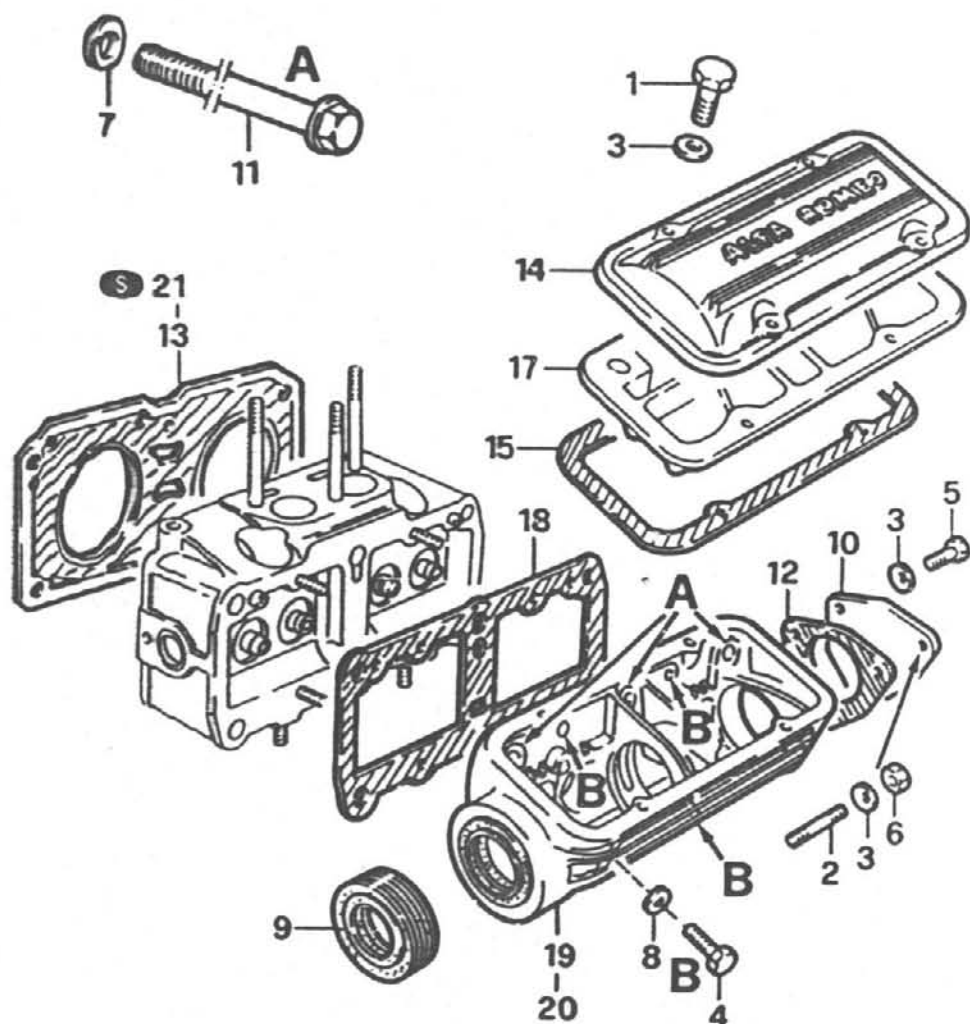

| pos. | TEILNUMMER | ref. | mg. benennung |
|------|-------------|------|-------------------|
| 1 | 00109 U2623 | | 8 SCHRAUBE |
| 2 | 02100 08890 | | 1 STEHBOLZEN |
| 3 | 00111 94379 | | 14 SCHEIBE |
| 4 | 00160 43621 | | 8 SCHRAUBE |
| 5 | 00109 02221 | | 5 SCHRAUBE |
| 6 | 00158 96211 | | 1 MUTTER |
| 7 | 00135 79771 | | 12 SCHEIBE |
| 8 | 00126 01379 | | 8 SCHEIBE |
| 9 | 00605 02913 | | 2 DICHTRING |
| 10 | 00605 02916 | | 2 DECKEL |
| 11 | 00605 03001 | | 12 SCHRAUBE |
| 12 | 00605 03007 | | 2 DICHTUNG |
| 13 | 00605 03099 | | 2 DICHTUNG |
| 14 | 00605 03165 | | 2 DECKEL |
| 15 | 00605 03303 | | 2 DICHTUNG |
| 17 | 00605 04787 | | 2 OELWANNENDECKEL |
| 18 | 00605 03916 | | 2 DICHTUNG |
| 19 | 00607 50720 | ◆ | 1 LAGERUNG |
| 20 | 00607 50721 | ◆ | 1 LAGERUNG |
| 21 | 00607 55017 | ≡ | 2 DICHTUNG |

- ◆ Links
- ◆ Rechts
- ≡ Schadstoff frei

C13

SPRINT
Ed. 57
Meccanica

1-1989

TAV. 02.80

c.c. 32

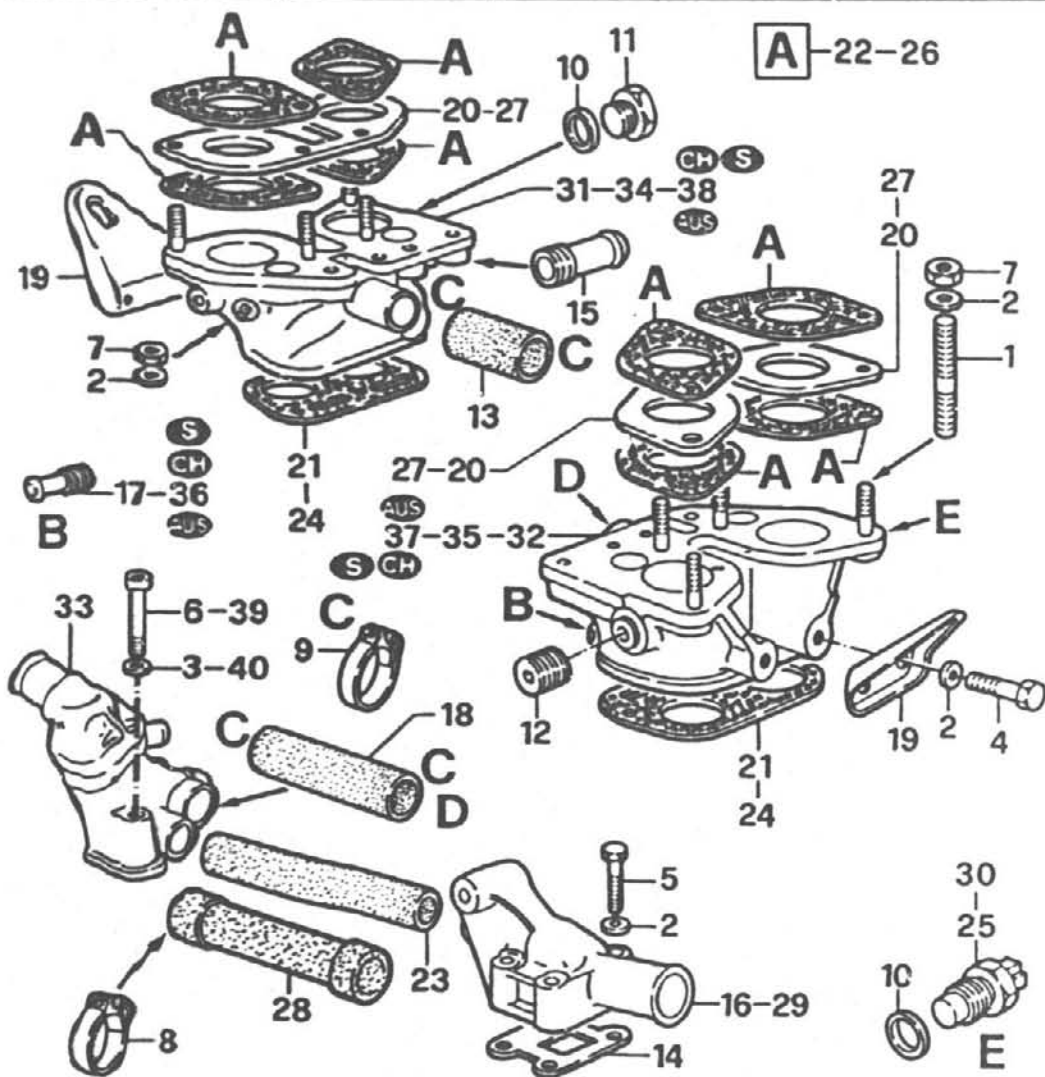

| pos. | TEILNUMMER | ref. | mg. benennung |
|------|-------------------|-------|-------------------|
| 1 | 02100 08066 | | 8 STEHBOLZEN |
| 2 | 02100 81434 00 00 | | 22 SCHEIBE |
| 3 | 02100 81437 00 00 | | 1 SCHEIBE Ø 10,5 |
| 4 | 00160 43411 | | 4 SCHRAUBE |
| 5 | 00160 44121 | | 4 SCHRAUBE |
| 6 | 00143 08121 | | 1 SCHRAUBE M10X60 |
| 7 | 00161 00811 | | 14 MUTTER |
| 8 | 00131 01590 | | 2 SCHELLE |
| 9 | 00131 01790 | | 4 SCHELLE |
| 10 | 00102 80050 | | 2 DICHTUNG |
| 11 | 02360 31504 | | 1 STOPFEN |
| 12 | 00102 69650 | | 1 STOPFEN |
| 13 | 00101 29086 | | 1 ROHR |
| 14 | 00605 02974 | | 1 DICHTUNG |
| 15 | 00605 03019 | | 1 VERTEILER |
| 16 | 00605 17608 | | 1 STUTZEN |
| 17 | 00605 04849 | | 4 VERTEILER |
| 18 | 00605 04843 | | 1 ROHR |
| 19 | 00605 17643 | | 2 PLATTE |
| 20 | 00605 17644 | ▲ | 2 ISOLIERSTOFF |
| 21 | 00605 17645 | ▲ | 2 DICHTUNG |
| 22 | 00605 17646 | ▲ | 8 DICHTUNG |
| 23 | 00605 17647 | | 1 ROHR |
| 24 | 00605 04851 | ● □ □ | 2 DICHTUNG |
| 25 | 00607 38378 | ▶ | 1 GEBER |

▲ c.c. 13

● c.c. 17

□ c.c. 1.795 R.O.N.

▣ c.c. 1.395 R.O.N.

▶ JAEGER



C14

SPRINT
Ed. 87
Meccanica
1-1989

TAV. 02.80

c.c. 32

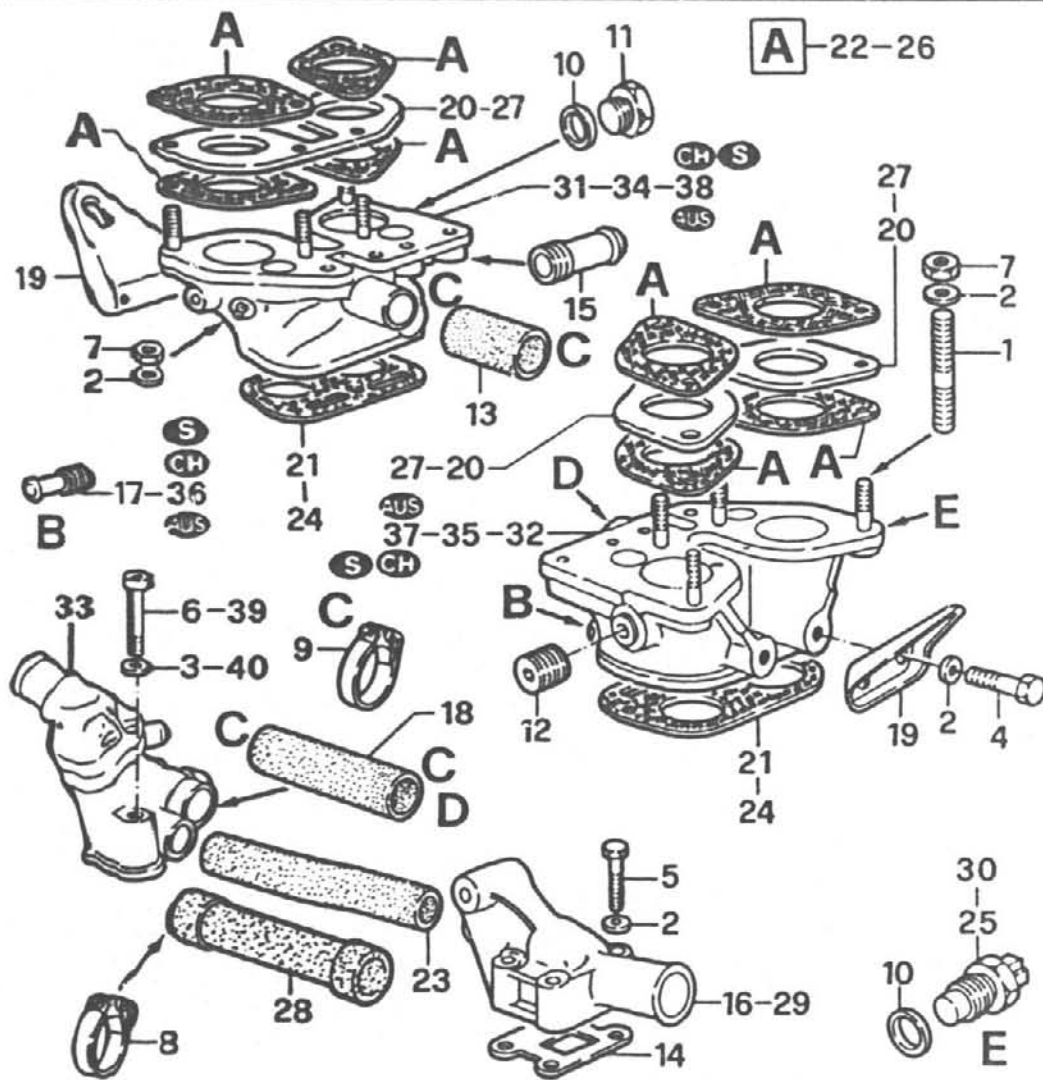

| pos. | TEILNUMMER | ref. | mg. | benennung |
|------|-------------------|---------|-----|----------------|
| 26 | 00605 24534 | ● | 8 | DICHTUNG |
| 27 | 00605 24535 | ● | 2 | ISOLIERSTOFF |
| 28 | 00605 04841 | ▼ | 1 | ROHR |
| 29 | 00605 04842 | ▼ | 1 | STUTZEN |
| 30 | 53043 80000 00 00 | ◀ | 1 | GEBER |
| 31 | 00605 36220 | ◆ ▲ | 1 | KRUEMMER |
| 32 | 00605 36221 | ◆ ▲ | 1 | KRUEMMER |
| 33 | 00605 04838 | | 1 | THERMOSTAT |
| 34 | 00605 04850 | ◆ ● ◻ ◻ | 1 | KRUEMMER |
| 35 | 00605 04847 | ◆ ● ◻ ◻ | 1 | KRUEMMER |
| 36 | 00607 39049 | | 4 | VERTEILER |
| 37 | 00607 48197 | ◆ | 1 | KRUEMMER |
| 38 | 00607 48198 | ◆ | 1 | KRUEMMER |
| 39 | 00160 44421 | | 1 | SCHRAUBE M8X60 |
| 40 | 02100 81414 00 00 | | 1 | SCHEIBE Ø 8,3 |

● c.c. 1.7
▼ /... TAV. B
◀ BORLETTI
▲ Rechte

▲ c.c. 1.3
◆ Links
◻ c.c. 1.7 95 R.O.N.

C15

SPRINT
Ed. 87
Meccanica

1-1989

I.E.

TAV. 02.80/5

c.c. 32

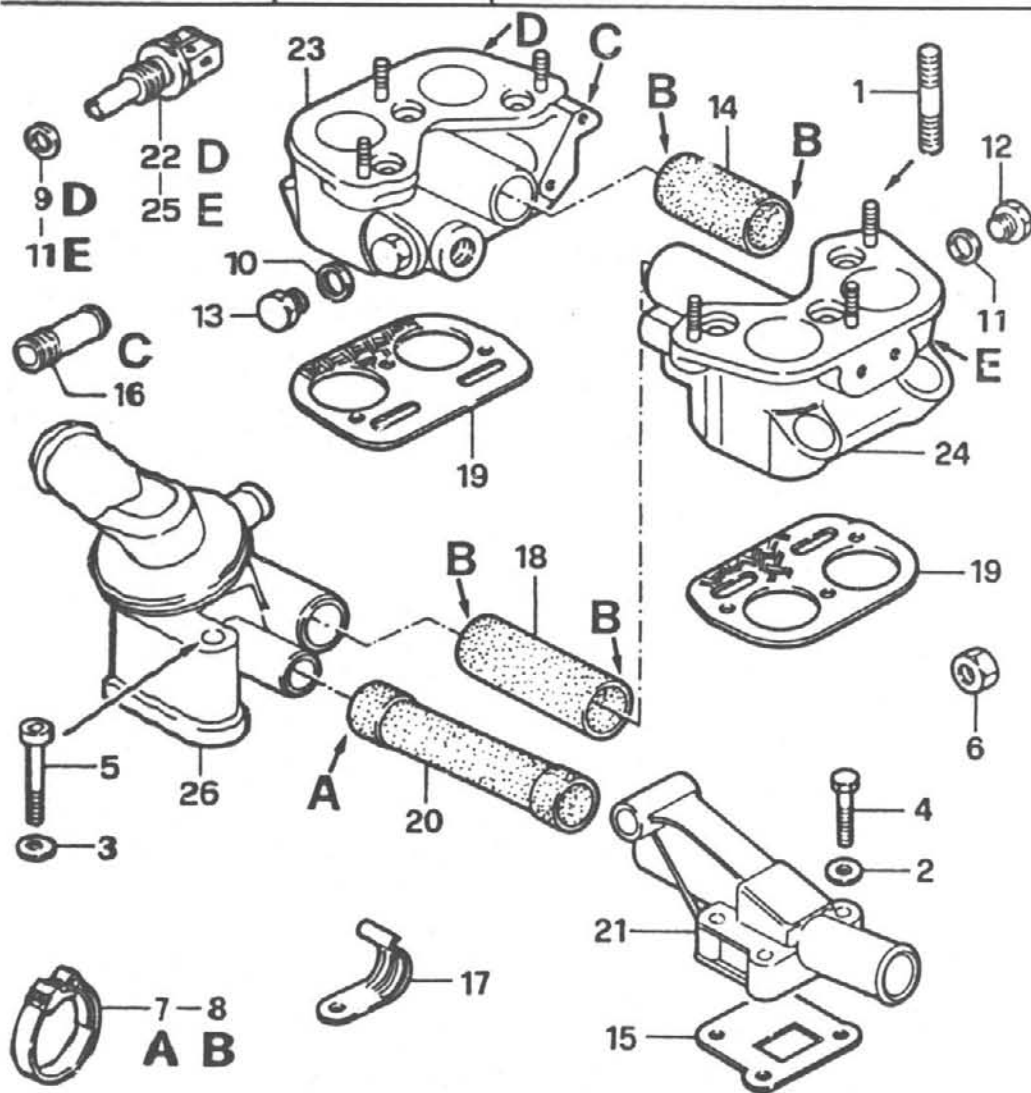

| pos. | TEILNUMMER | ref. | mg. | benennung |
|------|-------------------|------|-----|--------------|
| 1 | 02100 08066 | | 8 | STEBOLZEN |
| 2 | 02100 81434 00 00 | | 22 | SCHEIBE |
| 3 | 02100 81437 00 00 | | 1 | SCHEIBE |
| 4 | 00160 44121 | | 4 | SCHRAUBE |
| 5 | 00143 08121 | | 1 | SCHRAUBE |
| 6 | 00161 00821 | | 14 | MUTTER |
| 7 | 00131 01590 | | 2 | SCHELLE |
| 8 | 00131 01790 | | 4 | SCHELLE |
| 9 | 00102 98460 | | 1 | DICHTUNG |
| 10 | 00102 61160 | | 1 | DICHTUNG |
| 11 | 00102 80050 | | 1 | SCHEIBE |
| 12 | 02360 31503 | | 1 | STOPFEN |
| 13 | 02360 31504 | | 1 | STOPFEN |
| 14 | 00101 29086 | | 1 | ROHR |
| 15 | 00605 02974 | | 1 | DICHTUNG |
| 16 | 00605 03019 | | 1 | VERTEILER |
| 17 | 00605 03067 | | 2 | WINKELSTUECK |
| 18 | 00605 04843 | | 1 | ROHR |
| 19 | 00605 04851 | | 2 | ISOLIERSTOFF |
| 20 | 00605 04841 | | 1 | ROHR |
| 21 | 00605 04842 | | 1 | STUTZEN |
| 22 | 00605 13205 | | 1 | TEMP.-GEBER |
| 23 | 00966 76032 | ↗ | 1 | KRUEMMER |
| 24 | 00966 09821 | ↖ | 1 | KRUEMMER |
| 25 | 53043 80000 00 00 | | 1 | GEBER |

↗ Rechts
↖ Links



C16

SPRINT
Ed. 87
Meccanica
1-1989

I.E.

TAV. 02.80/5

c.c. 32

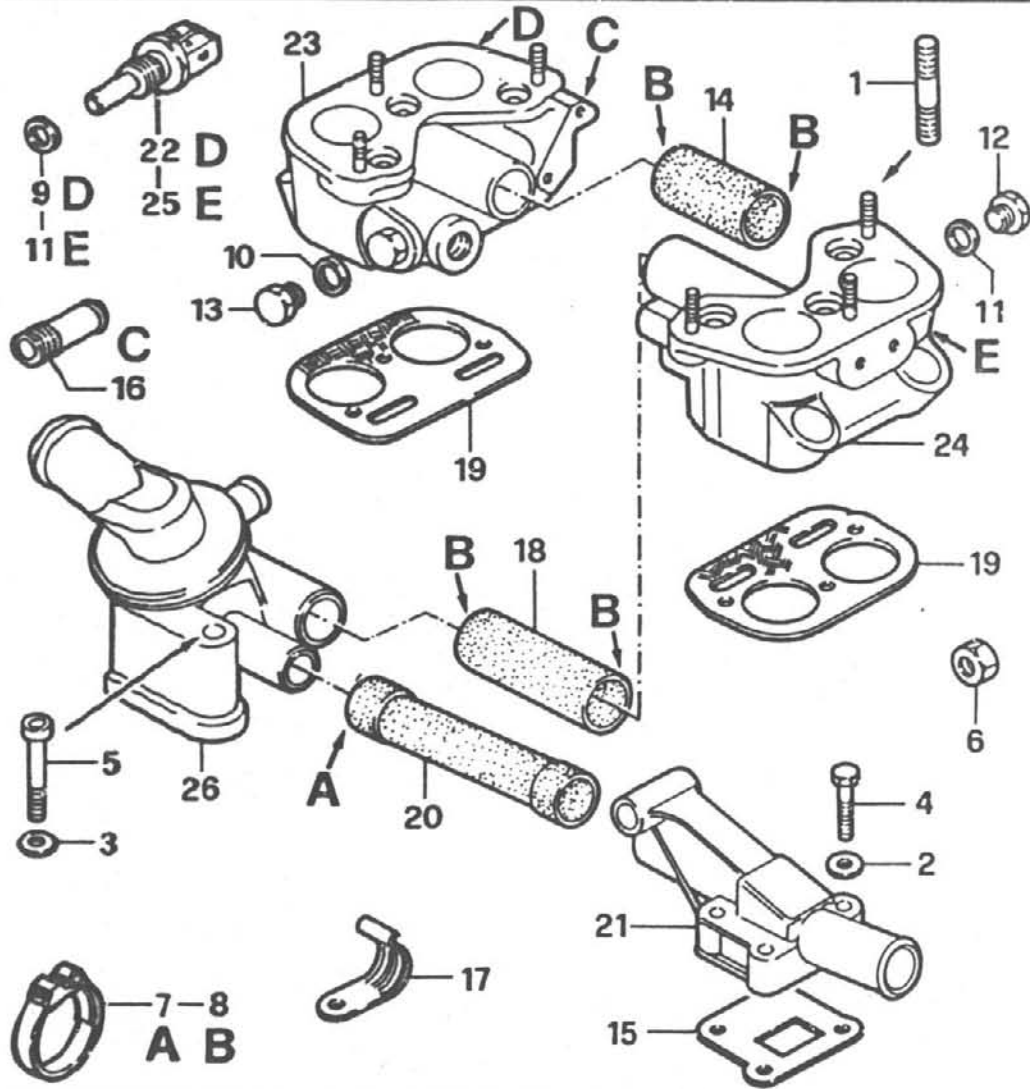

| pos. | TEILNUMMER | ref. | mg. | benennung | |
|------|-------------|------|-----|------------|---|
| 26 | 00605 C4838 | | 1 | THERMOSTAT | ↑ |

D

1

TAV 01.31/1

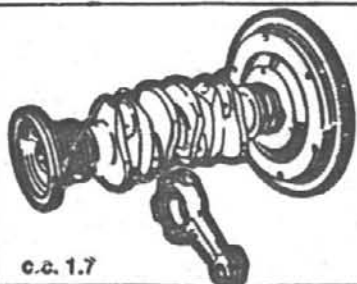

c.c. 1.7

2

TAV 01.31

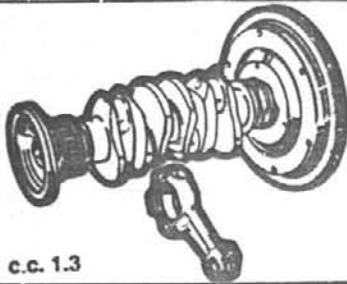

c.c. 1.3

3

TAV 01.31/5

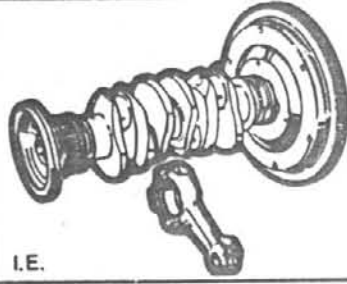

I.E.

4

TAV 01.32/1

c.c. 1.7

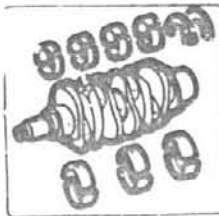

5

TAV 01.32/1

c.c. 1.7

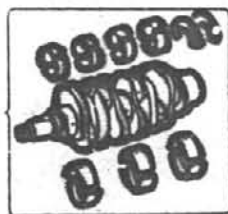

6

TAV 01.32

c.c. 1.3

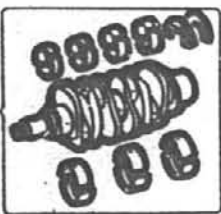

7

TAV 01.32

c.c. 1.3

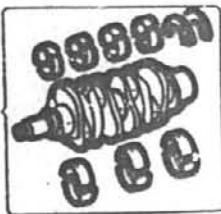

8

TAV 01.32/5

I.E.

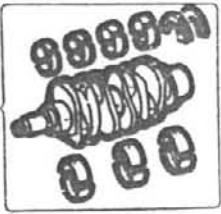

9

TAV 01.32/5

I.E.

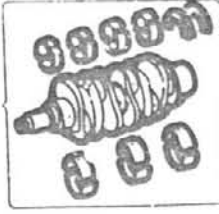

10

TAV 01.32/6

1.3 95 R.O.N.

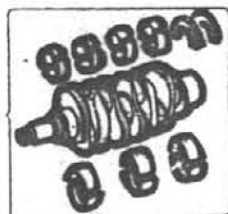

11

TAV 01.32/6

1.3 95 R.O.N.

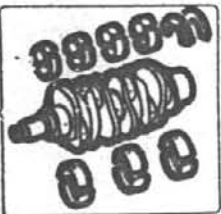

12

TAV

13

TAV 01.40/1

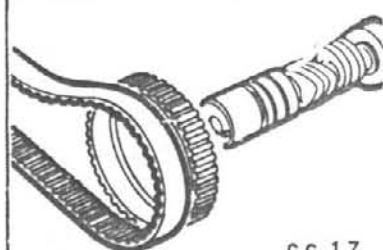

c.c. 1.7

14

TAV 01.40

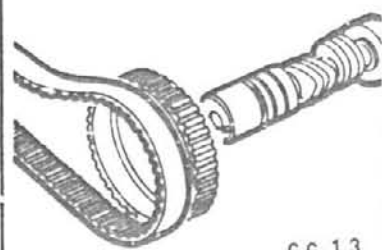

c.c. 1.3

15

TAV 01.40

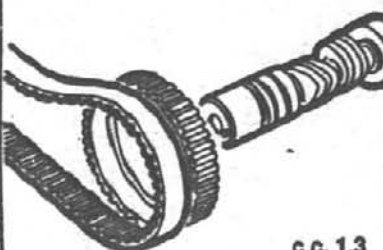

c.c. 1.3

16

TAV 01.40/5

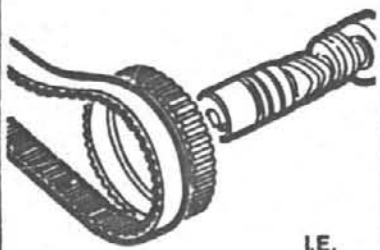

I.E.

17

TAV

18

TAV

19

TAV

D_i

SPRINT
Ed. 87
Meccanica
1-1989

c.c. 1.7

TAV. 01.31/1

c.c. 32

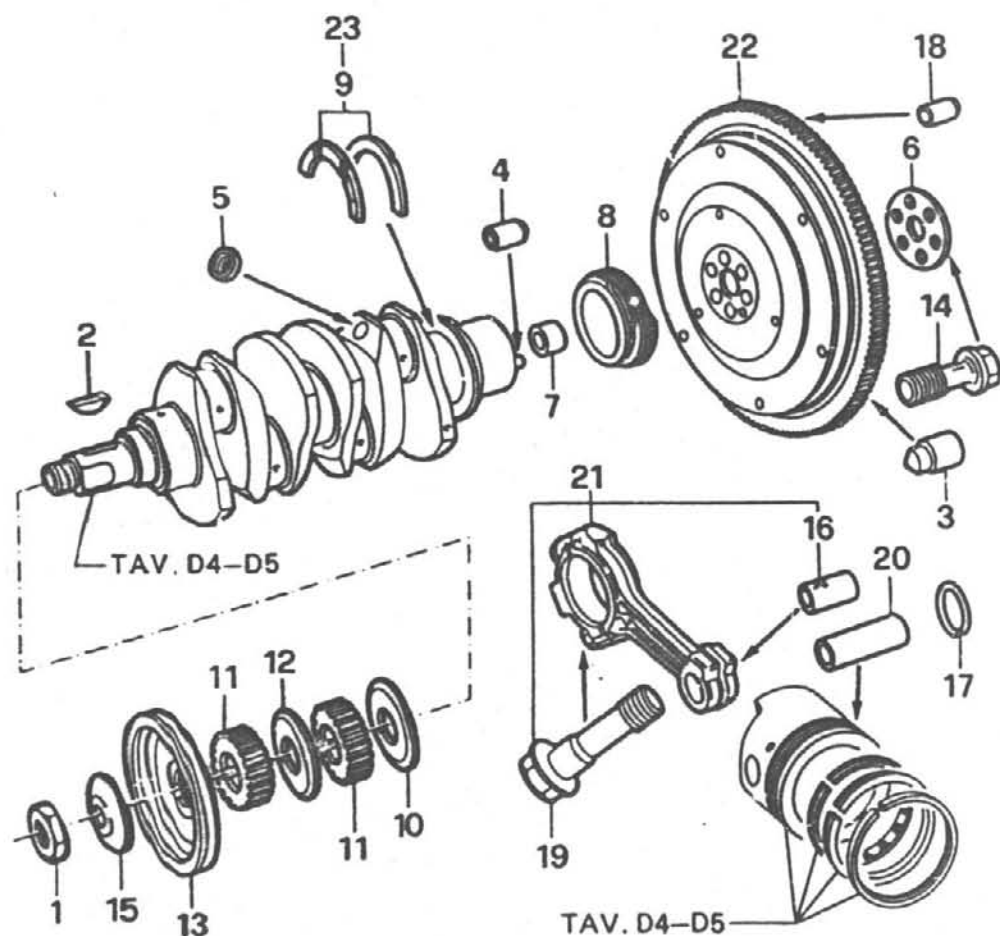

| pos. | TEILNUMMER | ref. | mg. | benennung |
|------|------------------------|------|-----|------------------|
| 1 | 00107 26711 | | 1 | MUTTER |
| 2 | 00102 06020 | | 1 | ZUNGE |
| 3 | 00108 41320 | | 1 | PASSTIFT |
| 4 | 00108 42020 | | 3 | PASSTIFT |
| 5 | 00143 28300 | | 4 | STOPFEN |
| 6 | 00605 02896 | | 1 | SCHEIBE |
| 7 | 00605 02897 | | 1 | BUECHSE |
| 8 | 00605 02898 | | 1 | ZAHNRAD |
| 9 | 00605 03028 | | 2 | HALBRING |
| 10 | 00605 02917 | | 1 | SCHEIBE |
| 11 | 00605 03038 | | 2 | RIEME VSCHLEIBE |
| 12 | 00605 02918 | | 1 | ABSTANDSTUECK |
| 13 | 00605 02956 | | 1 | RIEMENSCHLEIBE |
| 14 | 00605 03006 | | 6 | SCHRAUBE |
| 15 | 00605 03128 | | 1 | SCHEIBE |
| 16 | 00605 03148 | | 4 | BUECHSE |
| 17 | 00605 03149 | | 8 | RING |
| 18 | 00605 03290 | | 3 | PASSTIFT |
| 19 | 00605 03295 | | 8 | SCHRAUBE |
| 20 | 00605 03668 | | 1 | KOLBENBOLZEN |
| 21 | 00605 04285 | | 4 | PLEUELSTANGE |
| 22 | 00605 15021 | | 1 | SCHWUNGRAD |
| 23 | 00607 48219 | | 2 | HALBRING + 0,127 |

D₂

SPRINT
Ed. 87
Meccanica

1-1989

c.c. 1.3

TAV. 01.31

c.c. 32

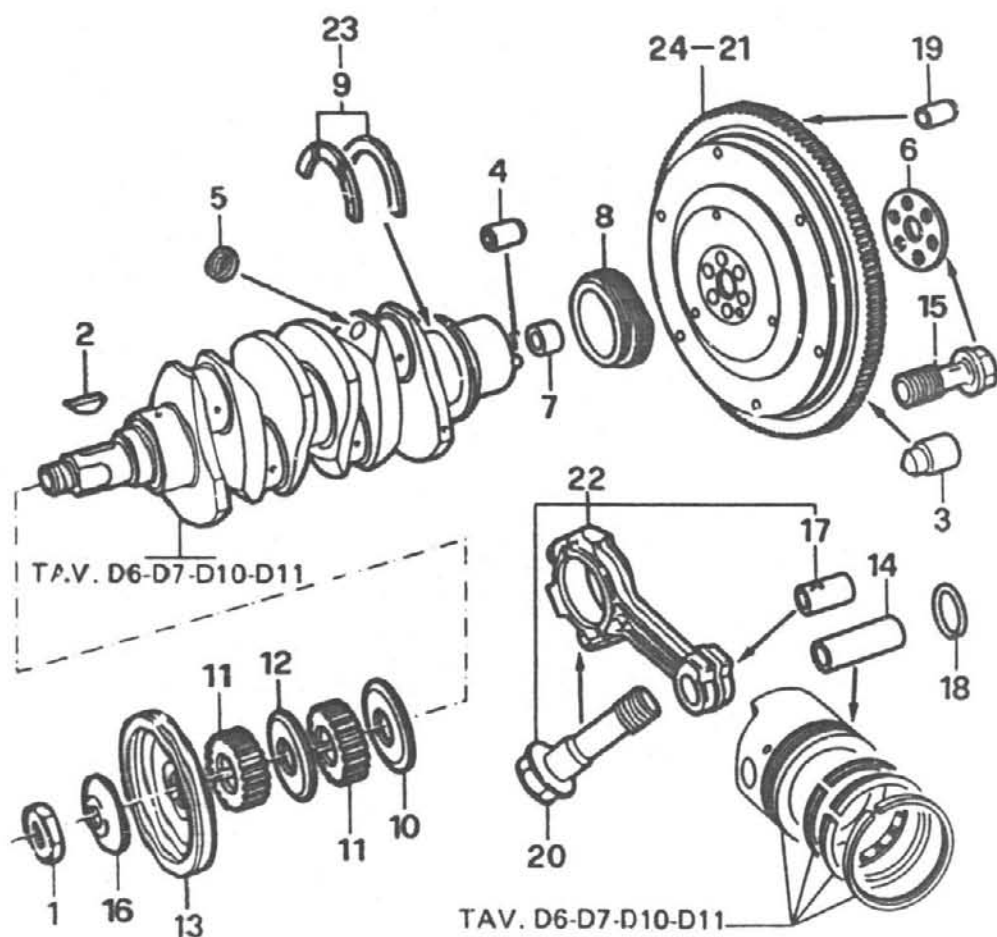

| pos. | TEILNUMMER | ref. | mg. | benennung |
|------|------------------------|------|-----|-------------------|
| 1 | 00107 25711 | | 1 | MUTTER |
| 2 | 00102 06020 | | 1 | ZUNGE |
| 3 | 00100 41320 | | 1 | PASSTIFT |
| 4 | 00108 42020 | | 3 | PASSTIFT |
| 5 | 00143 28300 | | 4 | STOPFEN |
| 6 | 00605 02896 | | 1 | SCHEIBE |
| 7 | 00605 02897 | | 1 | BUECHSE |
| 8 | 00605 02898 | | 1 | ZAHNRAD |
| 9 | 00605 03028 | | 2 | HALBRING |
| 10 | 00605 02917 | | 1 | SCHEIBE |
| 11 | 00605 03038 | | 2 | RIEMENSCHLEIFE |
| 12 | 00605 02918 | | 1 | ABSTANDSTUECK |
| 13 | 00605 02956 | | 1 | RIEMENSCHLEIFE |
| 14 | 00605 15694 | | 1 | KOLBENBOLZEN |
| 15 | 00605 03006 | | 6 | SCHRAUBE |
| 16 | 00605 03128 | | 1 | SCHEIBE |
| 17 | 00605 03148 | | 4 | BUECHSE |
| 18 | 00605 03149 | | 8 | RING |
| 19 | 00605 03290 | | 3 | PASSTIFT |
| 20 | 00605 03295 | | 8 | SCHRAUBE |
| 21 | 00605 36182 | | 1 | SCHWUNGRAD |
| 22 | 00605 04286 | | 4 | PLEUELSTANGE |
| 23 | 00607 48219 | | 2 | HALBRING + 0,1270 |
| 24 | 00605 04550 | ■ | 1 | SCHWUNGRAD |

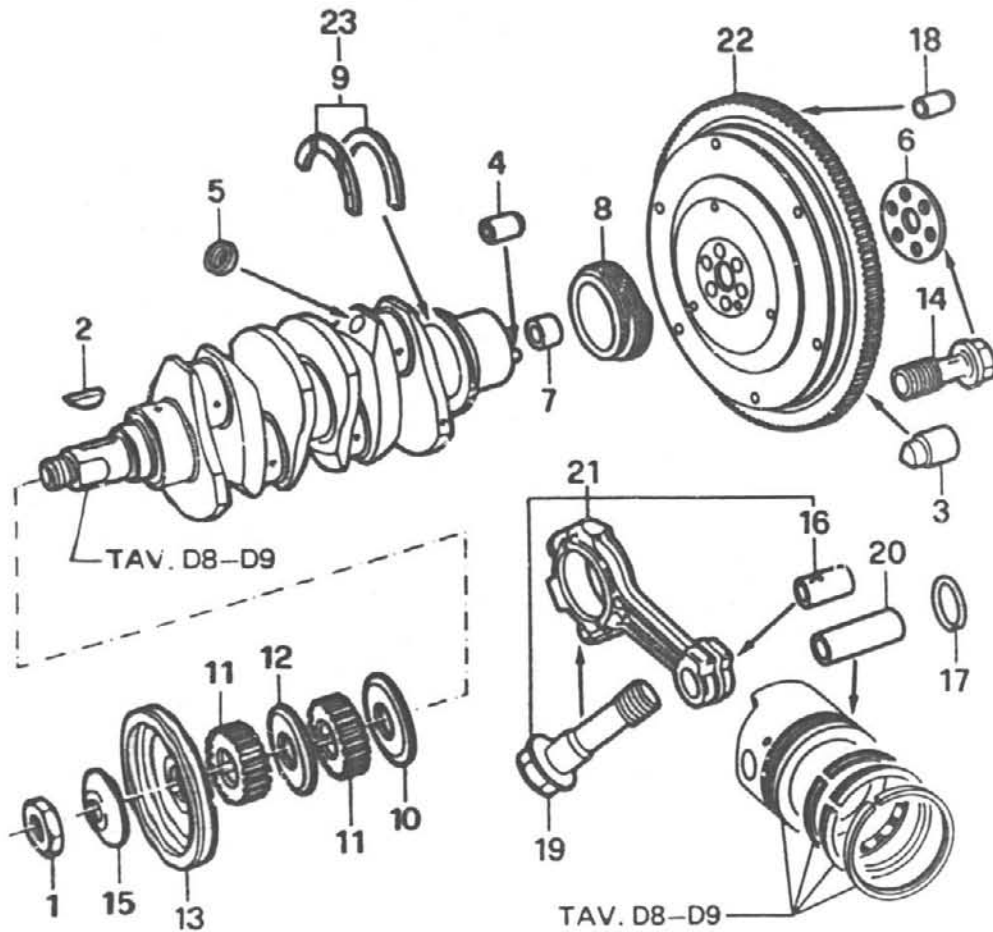

| pos. | TEILNUMMER | ref. | mg. | benennung |
|------|------------------------|------|-----|------------------|
| 1 | 00107 26711 | | 1 | MUTTER |
| 2 | 00102 06020 | | 1 | ZUNGE |
| 3 | 00108 41320 | | 1 | PASSTIFT |
| 4 | 00108 42020 | | 3 | PASSTIFT |
| 5 | 00143 28300 | | 4 | STOPFEN |
| 6 | 00605 02896 | | 1 | SCHEIBE |
| 7 | 00605 02897 | | 1 | HUELSE |
| 8 | 00605 02898 | | 1 | ZAHNRAD |
| 9 | 00605 03028 | | 2 | HALBRING |
| 10 | 00605 02917 | | 1 | ABSTANDSTUECK |
| 11 | 00605 03038 | | 2 | RIEMENSCHLEIBE |
| 12 | 00605 02918 | | 1 | ABSTANDSTUECK |
| 13 | 00605 02956 | | 1 | RIEMENSCHLEIBE |
| 14 | 00605 03006 | | 6 | SCHRAUBE |
| 15 | 00605 03128 | | 1 | SCHEIBE |
| 16 | 00605 03148 | | 4 | BUECHSE |
| 17 | 00605 03149 | | 8 | RING |
| 18 | 00605 03290 | | 3 | PASSTIFT |
| 19 | 00605 03295 | | 8 | SCHRAUBE |
| 20 | 00605 03668 | | 1 | KOLBENBOLZEN |
| 21 | 00605 04286 | | 4 | PLEUELSTANGE |
| 22 | 00605 38443 | | 1 | SCHWUNGRAD |
| 23 | 00607 48219 | | 2 | HALBRING + 0,127 |

D₄

SPRINT
Ed. 87
Meccanica

1-1989

c.c. 1.7

TAV. 01.32/1

c.c. 32

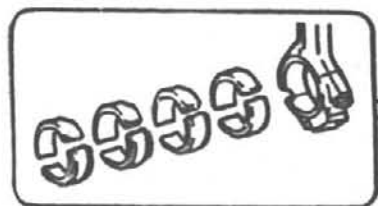

| | |
|---------|----|
| - 0,254 | 10 |
| - 0,508 | 11 |
| - 0,762 | 12 |
| - 1,016 | 13 |

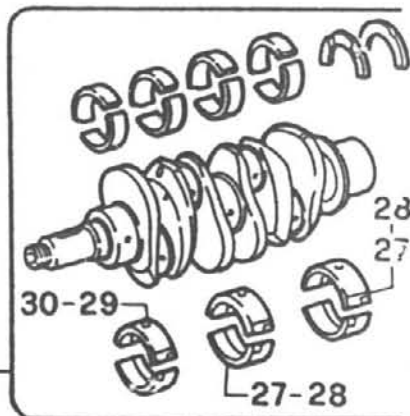

| | |
|---------|------|
| - 0,000 | 7-25 |
| - 0,000 | 8-26 |

31-9

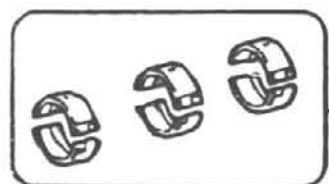

| | |
|---------|----|
| - 0,000 | 20 |
| - 0,254 | 21 |
| - 0,508 | 22 |
| - 0,762 | 23 |
| - 1,016 | 24 |

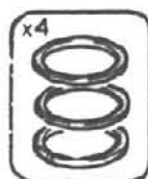

| | |
|-------|----|
| + 0,0 | 6 |
| + 0,2 | 17 |
| + 0,4 | 18 |
| + 0,6 | 19 |

| | | |
|---|----|-------|
| A | 1 | + 0,0 |
| B | 2 | + 0,0 |
| C | 3 | + 0,0 |
| D | 4 | + 0,0 |
| E | 5 | + 0,0 |
| | 14 | + 0,2 |
| | 15 | + 0,4 |
| | 16 | + 0,6 |
| A | 32 | + 0,0 |
| B | 33 | + 0,0 |
| C | 34 | + 0,0 |
| D | 35 | + 0,0 |
| E | 36 | + 0,0 |

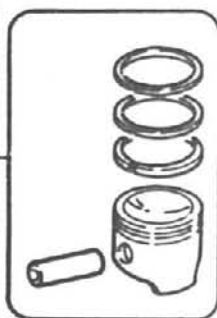

| pos. | TEILNUMMER | ref. | mg. benennung |
|------|-------------|------|---------------|
| 1 | 00607 30789 | ⊕ | 1 KOLBEN |
| 2 | 00607 30790 | ⊕ | 1 KOLBEN |
| 3 | 00607 50791 | ⊕ | 1 KOLBEN |
| 4 | 00607 50792 | ⊕ | 1 KOLBEN |
| 5 | 00607 50793 | ⊕ | 1 KOLBEN |
| 6 | 00607 50794 | | 1 SPRENGRING |
| 7 | 00607 50811 | RO | 1 HALBLAGER |
| 8 | 00607 50812 | 3L | 1 HALBLAGER |
| 9 | 00607 50813 | | 1 KURBELWELLE |
| 10 | 00607 50815 | | 1 HALBLAGER |
| 11 | 00607 50816 | | 1 HALBLAGER |
| 12 | 00607 50817 | | 1 HALBLAGER |
| 13 | 00607 50818 | | 1 HALBLAGER |
| 14 | 00607 50819 | ⊕ | 1 KOLBEN |
| 15 | 00607 50820 | ⊕ | 1 KOLBEN |
| 16 | 00607 50821 | ⊕ | 1 KOLBEN |
| 17 | 00607 50822 | | 1 SPRENGRING |
| 18 | 00607 50823 | | 1 SPRENGRING |
| 19 | 00607 50824 | | 1 SPRENGRING |
| 20 | 00607 50832 | | 1 HALBLAGER |
| 21 | 00607 50833 | | 1 HALBLAGER |
| 22 | 00607 50834 | | 1 HALBLAGER |
| 23 | 00607 50835 | | 1 HALBLAGER |
| 24 | 00607 50836 | | 1 HALBLAGER |
| 25 | 00605 15018 | △ RO | 8 HALBLAGER |

⊕ MOX IDIAL
△ ?... ◆



D₅

SPRINT
Ed. 87
Meccanica

1-1989

c.c. 1.7

TAV. 01.32/1

c.c. 32

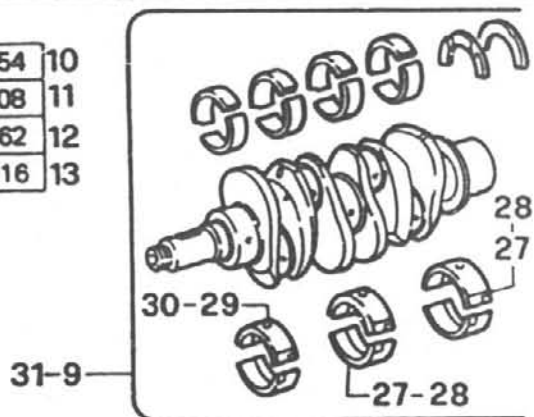
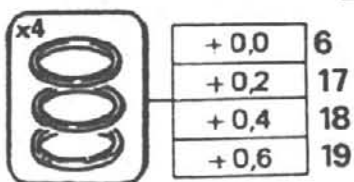
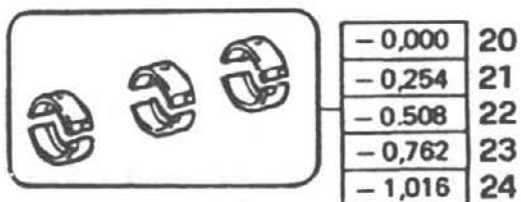
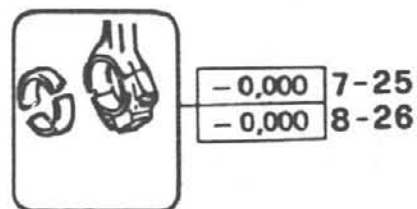

| | | |
|---|----|------|
| A | 1 | +0,0 |
| B | 2 | +0,0 |
| C | 3 | +0,0 |
| D | 4 | +0,0 |
| E | 5 | +0,0 |
| | 14 | +0,2 |
| | 15 | +0,4 |
| | 16 | +0,6 |
| A | 32 | +0,0 |
| B | 33 | +0,0 |
| C | 34 | +0,0 |
| D | 35 | +0,0 |
| E | 36 | +0,0 |

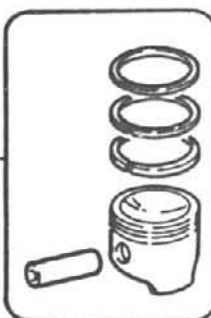

| pos. | TEILNUMMER | ref. | mg. | benennung |
|------|-------------|--|-----|-------------|
| 26 | 00605 15019 | ▲ BL | 8 | HALBLAGER |
| 27 | 00605 43153 | ▲ RO | 4 | HALBLAGER |
| 28 | 00605 43154 | ▲ BL | 4 | HALBLAGER |
| 29 | 00607 55018 | ▲ RO | 2 | HALBLAGER |
| 30 | 00607 55019 | BL ▲ | 2 | HALBLAGER |
| 31 | 00607 55020 | ◆ | 1 | KURBELWELLE |
| 32 | 00607 55023 | ⊖ | 1 | KOLBEN |
| 33 | 00607 55024 | ⊖ | 1 | KOLBEN |
| 34 | 00607 55025 | ⊖ | 1 | KOLBEN |
| 35 | 00607 55026 | ⊖ | 1 | KOLBEN |
| 36 | 00607 55027 | ⊖ | 1 | KOLBEN |

▲ ?... ◆
◆ Nitriert
⊖ BORGO

D₆

SPRINT
Ed. 87
Meccanica

1-1989

c.c. 1.3

TAV. 01.32

c.c. 32

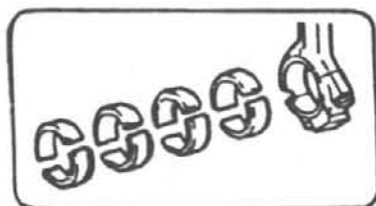

| | |
|--------|-----|
| -0,000 | 1-2 |
| -0,254 | 21 |
| -0,508 | 22 |
| -0,762 | 23 |
| -1,016 | 24 |

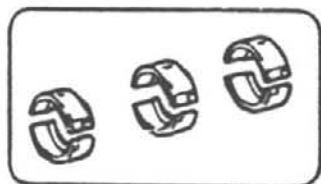

| | |
|--------|----|
| -0,000 | 6 |
| -0,254 | 7 |
| -0,508 | 8 |
| -0,762 | 9 |
| -1,016 | 10 |



| | |
|------|----|
| +0,0 | 11 |
| +0,2 | 3 |
| +0,4 | 4 |
| +0,6 | 5 |

| | |
|-------|------|
| 19 | +0,6 |
| 18 | +0,4 |
| 17 | +0,2 |
| 16÷12 | +0,0 |

E÷A

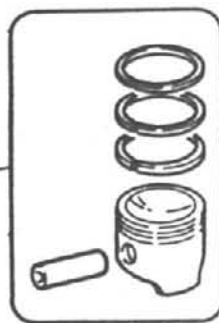
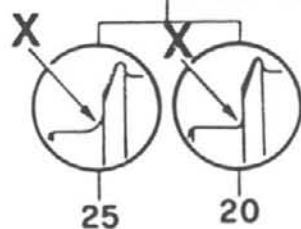
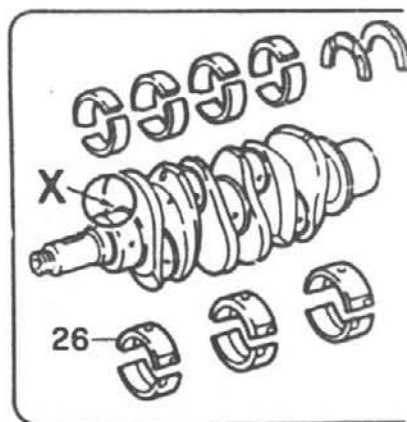

| pos. | TEILNUMMER | ref. | mg. | benennung |
|------|-------------|------|-----|-------------|
| 1 | 00607 50811 | RO | 1 | HALBLAGER |
| 2 | 00607 50812 | BL | 1 | HALBLAGER |
| 3 | 00607 50488 | | 1 | RINGSATZ |
| 4 | 00607 50489 | | 1 | RINGSATZ |
| 5 | 00607 50490 | | 1 | RINGSATZ |
| 6 | 00607 50492 | | 1 | LAGERSATZ |
| 7 | 00607 50497 | | 1 | LAGERSATZ |
| 8 | 00607 50498 | | 1 | LAGERSATZ |
| 9 | 00607 50499 | | 1 | LAGERSATZ |
| 10 | 00607 50500 | | 1 | LAGERSATZ |
| 11 | 00607 50519 | | 1 | RINGSATZ |
| 12 | 00607 50646 | | 1 | KOLBEN |
| 13 | 00607 50647 | | 1 | KOLBEN |
| 14 | 00607 50648 | | 1 | KOLBEN |
| 15 | 00607 50649 | | 1 | KOLBEN |
| 16 | 00607 50650 | | 1 | KOLBEN |
| 17 | 00607 50678 | | 1 | KOLBEN |
| 18 | 00607 50679 | | 1 | KOLBEN |
| 19 | 00607 50680 | | 1 | KOLBEN |
| 20 | 00607 50698 | | 1 | KURBELWELLE |
| 21 | 00607 50700 | | 1 | LAGERSATZ |
| 22 | 00607 50701 | | 1 | LAGERSATZ |
| 23 | 00607 50702 | | 1 | LAGERSATZ |
| 24 | 00607 50703 | | 1 | LAGERSATZ |
| 25 | 00607 55522 | ✓ | 1 | KURBELWELLE |

✓ Z... ✓ per X überdimensioniert



D₇

SPRINT
Ed. 87
Meccanica

1-1989

c.c. 1.3

TAV. 01.32

c.c. 32

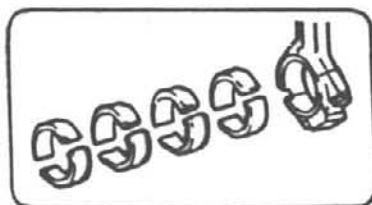

| | |
|--------|-----|
| -0,000 | 1-2 |
| -0,254 | 21 |
| -0,508 | 22 |
| -0,762 | 23 |
| -1,016 | 24 |

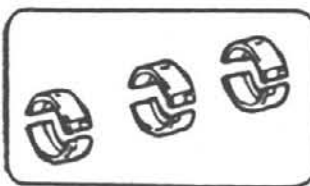

| | |
|--------|----|
| -0,000 | 6 |
| -0,254 | 7 |
| -0,508 | 8 |
| -0,762 | 9 |
| -1,016 | 10 |

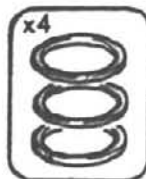

| | |
|------|----|
| +0,0 | 11 |
| +0,2 | 3 |
| +0,4 | 4 |
| +0,6 | 5 |

| | |
|-------|------|
| 19 | +0,6 |
| 18 | +0,4 |
| 17 | +0,2 |
| 16÷12 | +0,0 |

E÷A

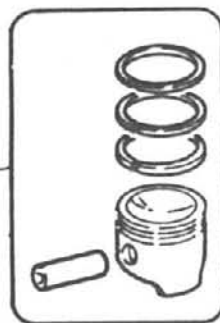
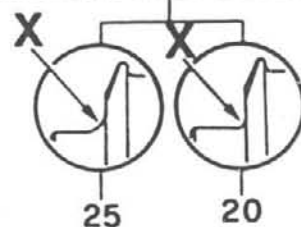
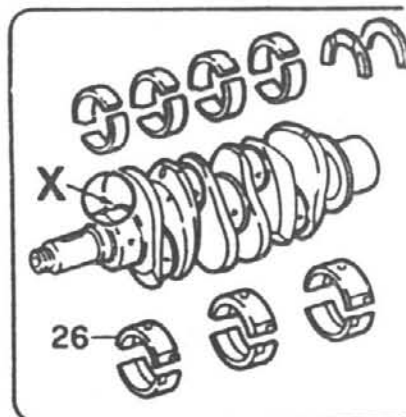

| pos. | TEILNUMMER | ref. | mg. | benennung | |
|------|-------------|-------------------------------------|-----|-----------|--|
| 26 | 00607 55519 | <input checked="" type="checkbox"/> | 2 | HALBLAGER | |

... per X tiberdimensioniert

D8

SPRINT
Ed. 87
Meccanica
1-1989

I.E.

TAV. 01.32/5

c.c. 32

| | |
|---------|---|
| - 1,016 | 8 |
| - 0,762 | 7 |
| - 0,508 | 6 |
| - 0,254 | 5 |



2
3
25
26

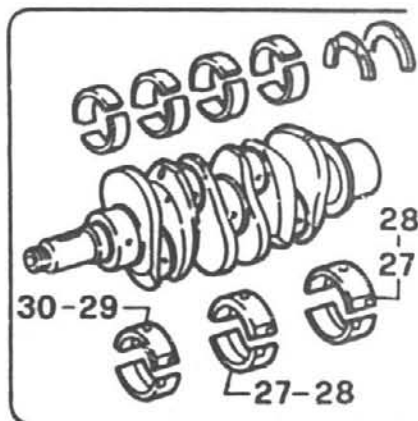

4
31

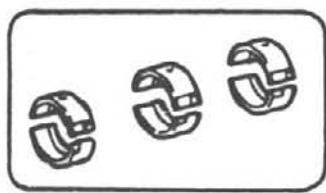

| | |
|---------|----|
| - 0,000 | 12 |
| - 0,254 | 13 |
| - 0,508 | 14 |
| - 0,762 | 15 |
| - 1,016 | 16 |

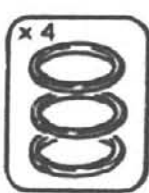

| | |
|-------|----|
| + 0,0 | 1 |
| + 0,2 | 9 |
| + 0,4 | 10 |
| + 0,6 | 11 |

21÷17
E ÷ A

| | |
|-------|----|
| + 0,6 | 24 |
| + 0,4 | 23 |
| + 0,2 | 22 |
| + 0,0 | 21 |

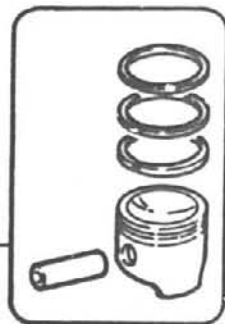

| pos. | TEILNUMMER | ref. | mg. benennung |
|------|-------------|------|----------------------|
| 1 | 00607 50794 | | 1 SPRENGRING |
| 2 | 00607 50811 | RO | 1 HALBLAGER |
| 3 | 00607 50812 | BL | 1 HALBLAGER |
| 4 | 00607 50813 | | 1 KURBELWELLE,KOMPL. |
| 5 | 00607 50815 | | 1 HALBLAGER |
| 6 | 00607 50816 | | 1 HALBLAGER |
| 7 | 00607 50817 | | 1 HALBLAGER |
| 8 | 00607 50818 | | 1 HALBLAGER |
| 9 | 00607 50822 | | 1 SPRENGRING |
| 10 | 00607 50823 | | 1 SPRENGRING |
| 11 | 00607 50824 | | 1 SPRENGRING |
| 12 | 00607 50832 | | 1 HALBLAGER |
| 13 | 00607 50833 | | 1 HALBLAGER |
| 14 | 00607 50834 | | 1 HALBLAGER |
| 15 | 00607 50835 | | 1 HALBLAGER |
| 16 | 00607 50836 | | 1 HALBLAGER |
| 17 | 00607 50859 | | 1 KOLBEN |
| 18 | 00607 50860 | | 1 KOLBEN |
| 19 | 00607 50861 | | 1 KOLBEN |
| 20 | 00607 50862 | | 1 KOLBEN |
| 21 | 00607 50863 | | 1 KOLBEN |
| 22 | 00607 50864 | | 1 KOLBEN |
| 23 | 00607 50865 | | 1 KOLBEN |
| 24 | 00607 50866 | | 1 KOLBEN |
| 25 | 00605 15018 | RO ▲ | 8 HALBLAGER |



D₉

SPRINT
Ed. 87
Meccanica
1-1989

I.E.

TAV. 01.32/5

c.c. 32

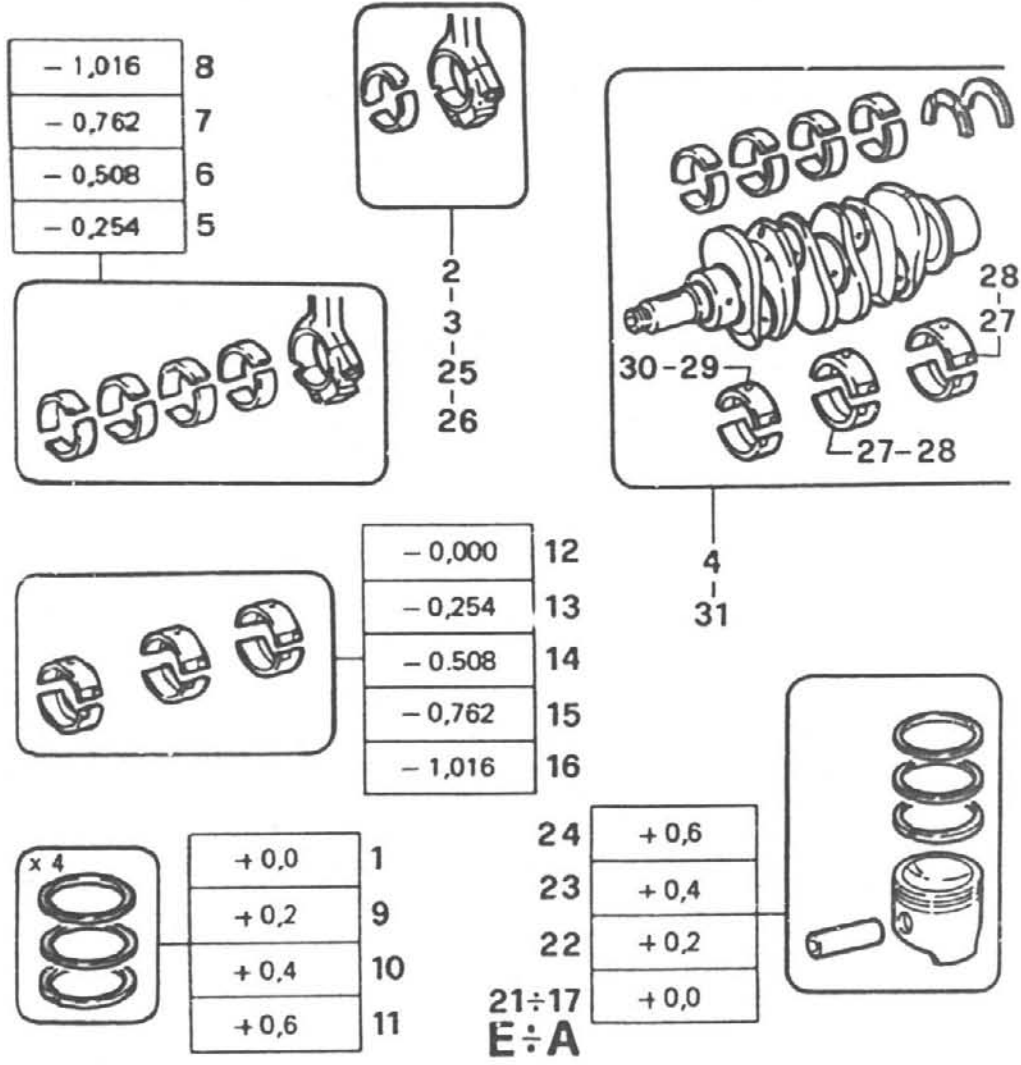

| pos. | TEILNUMMER | ref. | mg. | benennung |
|------|-------------|------|-----|--------------------|
| 26 | 00605 15019 | BL ▲ | 8 | HALBLAGER |
| 27 | 00605 43153 | RO ▲ | 4 | HALBLAGER |
| 28 | 00605 43154 | BL ▲ | 4 | HALBLAGER |
| 29 | 00607 55018 | RO ▲ | 2 | HALBLAGER |
| 30 | 00607 55019 | BL ▲ | 2 | HALBLAGER |
| 31 | 00607 55020 | ◆ | 1 | KURBELWELLE,KOMPL. |

▲ /... ◆
◆ Nitriert

D₁₀

SPRINT
Ed. 87
Meccanica

1-1989

c.c. 1.3 95 R.O.N.

TAV. 01.32/6

c.c. 32

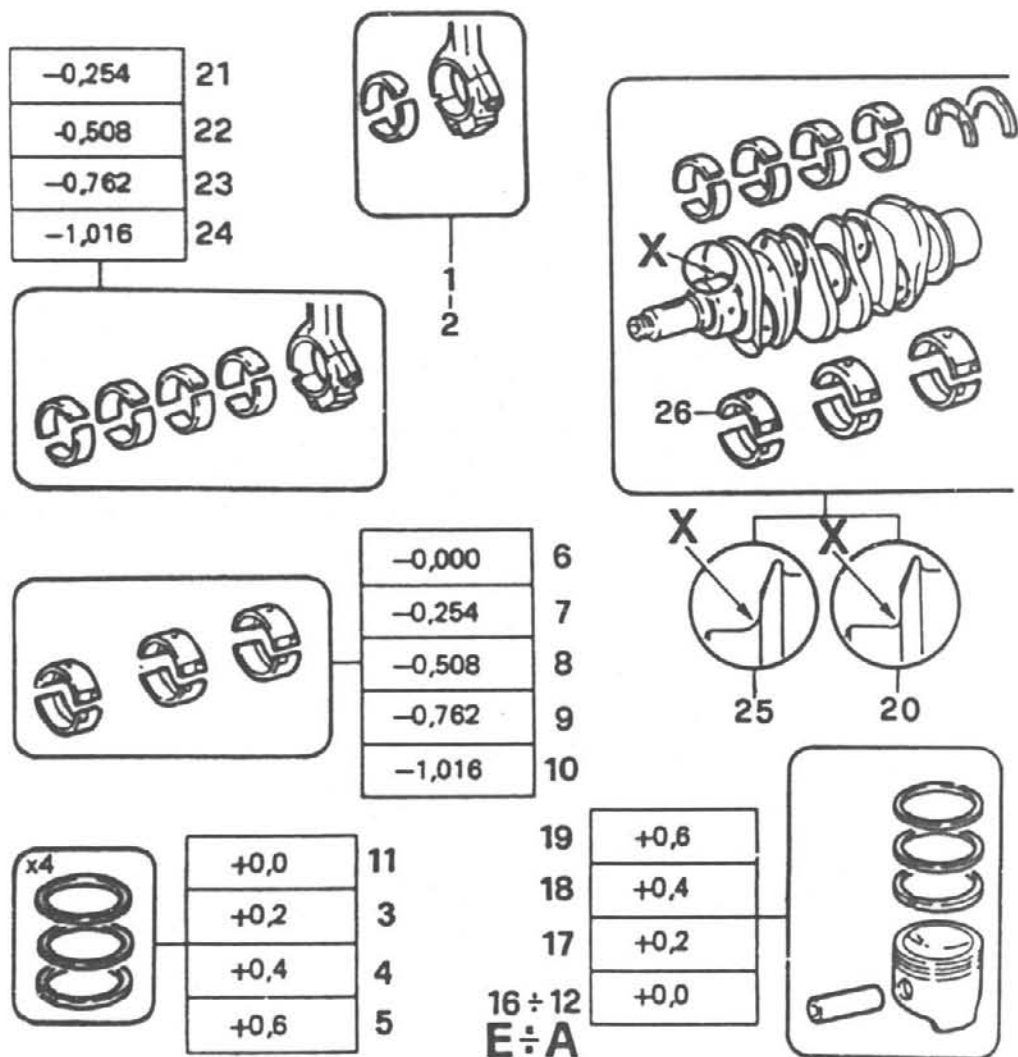

| pos. | TEILNUMMER | ref. | mg. | benennung |
|------|-------------|------|-----|-------------|
| 1 | 00607 50811 | RO | 1 | HALBLAGER |
| 2 | 00607 50812 | BL | 1 | HALBLAGER |
| 3 | 00607 50488 | | 1 | RINGSATZ |
| 4 | 00607 50489 | | 1 | RINGSATZ |
| 5 | 00607 50490 | | 1 | RINGSATZ |
| 6 | 00607 50492 | | 1 | LAGERSATZ |
| 7 | 00607 50497 | | 1 | LAGERSATZ |
| 8 | 00607 50498 | | 1 | LAGERSATZ |
| 9 | 00607 50499 | | 1 | LAGERSATZ |
| 10 | 00607 50500 | | 1 | LAGERSATZ |
| 11 | 00607 50519 | | 1 | RINGSATZ |
| 12 | 00607 50890 | | 1 | KOLBEN |
| 13 | 00607 50891 | | 1 | KOLBEN |
| 14 | 00607 50892 | | 1 | KOLBEN |
| 15 | 00607 50893 | | 1 | KOLBEN |
| 16 | 00607 50894 | | 1 | KOLBEN |
| 17 | 00607 50906 | | 1 | KOLBEN |
| 18 | 00607 50907 | | 1 | KOLBEN |
| 19 | 00607 50908 | | 1 | KOLBEN |
| 20 | 00607 50698 | | 1 | KURBELWELLE |
| 21 | 00607 50700 | | 1 | LAGERSATZ |
| 22 | 00607 50701 | | 1 | LAGERSATZ |
| 23 | 00607 50702 | | 1 | LAGERSATZ |
| 24 | 00607 50703 | | 1 | LAGERSATZ |
| 25 | 00607 55022 | ✓ | 1 | KURBELWELLE |

✓ 7... ✓ per X tiberdimensioniert



D₁₁

SPRINT
Ed. 87
Meccanica

1-1989

c.c. 1.3 95 R.O.N.

TAV. 01.32/6

c.c. 32

| pos. | TEILNUMMER | ref. | mg. | benennung |  |
|------|-------------|-------------------------------------|-----|-----------|---|
| 26 | 00607 55019 | <input checked="" type="checkbox"/> | 2 | HALBLAGER | |

| | |
|--------|----|
| -0,254 | 21 |
| -0,508 | 22 |
| -0,762 | 23 |
| -1,016 | 24 |



1
2

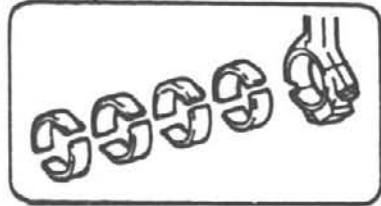
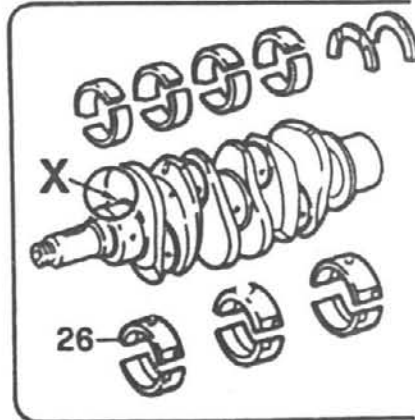

| | |
|--------|----|
| -0,000 | 6 |
| -0,254 | 7 |
| -0,508 | 8 |
| -0,762 | 9 |
| -1,016 | 10 |

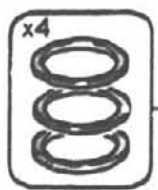
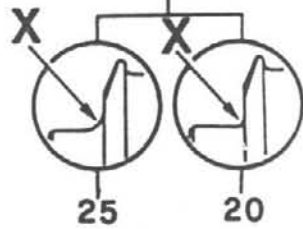

| | |
|------|----|
| +0,0 | 11 |
| +0,2 | 3 |
| +0,4 | 4 |
| +0,6 | 5 |

19
18
17
16 ÷ 12
E ÷ A

| | |
|------|----|
| +0,6 | 19 |
| +0,4 | 18 |
| +0,2 | 17 |
| +0,0 | 16 |

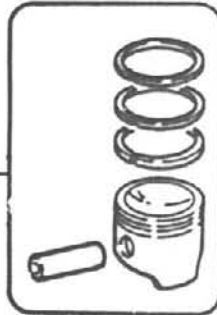

/.. per X überdimensioniert

D13

SPRINT
Ed. 87
Meccanica

1-1989

c.c. 1.7

TAV. 01.40/1

c.c. 32

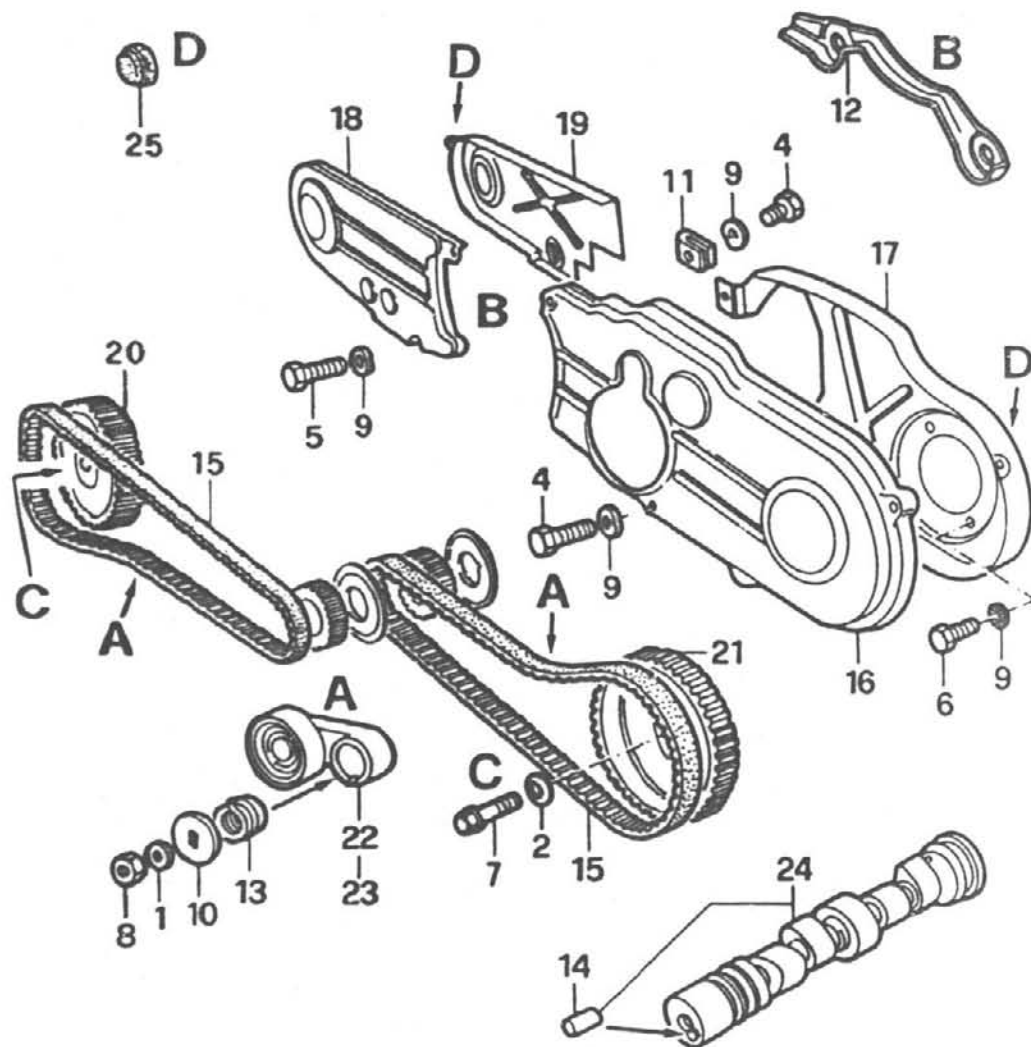

| pos. | TEILNUMMER | ref. | mg. benennung |
|------|-------------------|------|------------------|
| 1 | 02100 81437 00 00 | | 2 SCHEIBE |
| 2 | 02100 81440 00 00 | | 2 SCHEIBE |
| 4 | 00109 02411 | | 3 SCHRAUBE |
| 5 | 00109 03211 | | 2 SCHRAUBE |
| 6 | 00109 02121 | | 4 SCHRAUBE |
| 7 | 00109 35721 | | 2 SCHRAUBE |
| 8 | 00121 64711 | | 2 MUTTER |
| 9 | 00126 01279 | | 8 SCHEIBE |
| 10 | 00605 02922 | | 2 SCHEIBE |
| 11 | 00605 03003 | | 4 HALTER |
| 12 | 00605 03291 | | 1 BLECHTEIL |
| 13 | 00605 03292 | | 2 FEDER |
| 14 | 00605 03584 | | 2 PASSTIFT |
| 15 | 00605 15034 | | 2 RIEMEN |
| 16 | 00605 15055 | A | 1 DECKEL |
| 17 | 00605 15051 | P | 1 DECKEL |
| 18 | 00605 15054 | A | 1 DECKEL |
| 19 | 00605 15052 | P | 1 DECKEL |
| 20 | 00605 15036 | | 1 RIEMENSCHLEIFE |
| 21 | 00605 15037 | | 1 RIEMENSCHLEIFE |
| 22 | 00605 04224 | | 1 SPANNROLLE |
| 23 | 00605 04225 | | 1 SPANNROLLE |
| 24 | 00605 15038 | | 2 NOCKENWELLE |
| 25 | 00605 15053 | | 2 STOPFEN |

◆ Links
◆ Rechts

D14

SPRINT
Ed. 87
Meccanica
1-1989

c.c. 1.3

TAV. 01.40

c.c. 32

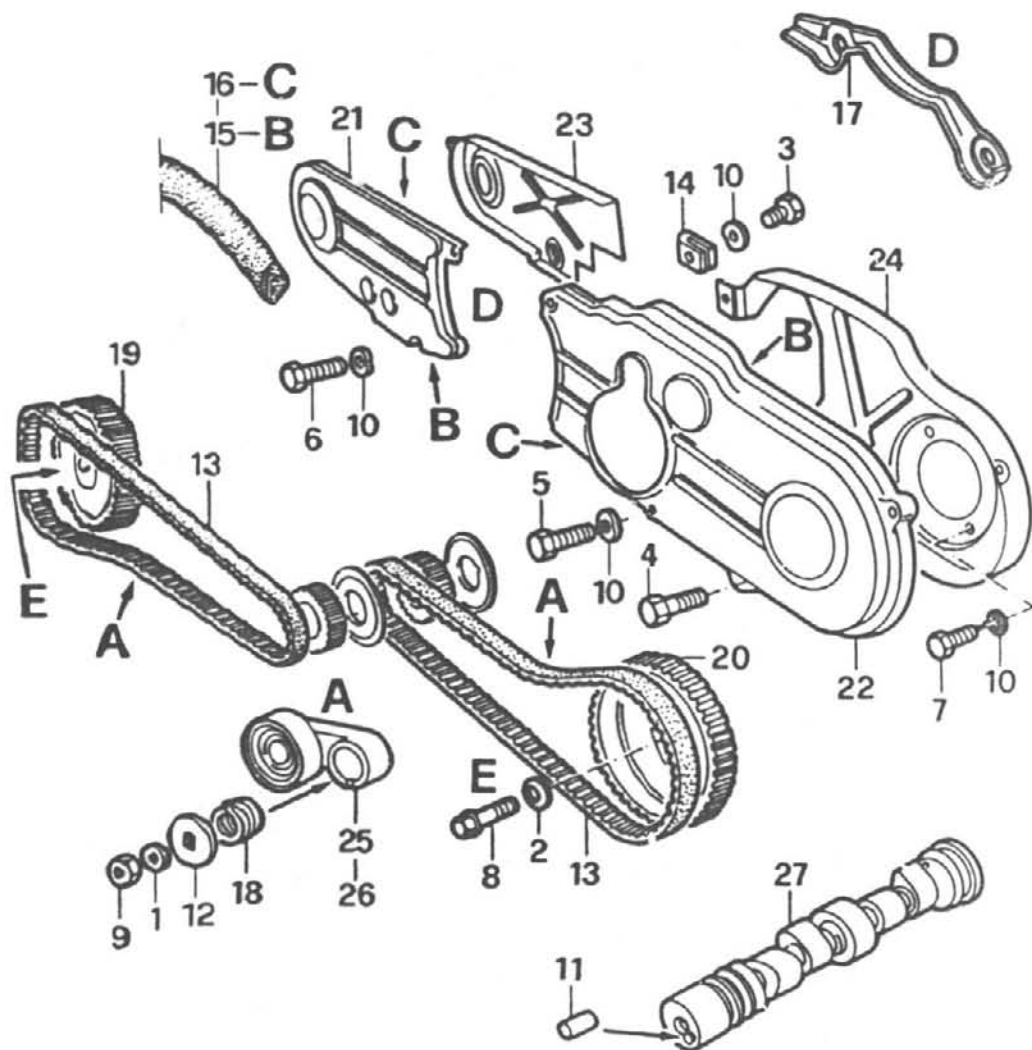

| pos. | TEILNUMMER | ref. | mg. | benennung |
|------|-------------------|------|-----|------------------|
| 1 | 02100 81437 00 00 | | 2 | SCHEIBE |
| 2 | 02100 81440 00 00 | | 2 | SCHEIBE |
| 3 | 00109 02211 | | 2 | SCHRAUBE |
| 4 | 00109 02411 | | 1 | SCHRAUBE |
| 5 | 00109 02611 | | 3 | SCHRAUBE |
| 6 | 00109 03211 | | 2 | SCHRAUBE |
| 7 | 00109 02121 | | 4 | SCHRAUBE |
| 8 | 00109 35721 | | 2 | SCHRAUBE |
| 9 | 00121 64711 | | 2 | MUTTER |
| 10 | 00126 01279 | | 2 | SCHEIBE |
| 11 | 00108 41520 | | 2 | PASSTIFT |
| 12 | 00605 02922 | | 2 | SCHEIBE |
| 13 | 00605 03002 | | 2 | RIEMEN |
| 14 | 00605 03003 | | 4 | HALTER |
| 15 | 00605 17512 | | 2 | DICHTUNG L = 140 |
| 16 | 00605 17513 | | 2 | DICHTUNG L = 80 |
| 17 | 00605 03291 | | 1 | BLECHTEIL |
| 18 | 00605 03292 | | 2 | FEDER |
| 19 | 00605 15036 | ♦ | 1 | RIEMENSCHLEIFE |
| 20 | 00605 15037 | ♦ | 1 | RIEMENSCHLEIFE |
| 21 | 00605 04220 | A ♦ | 1 | DECKEL |
| 22 | 00605 04221 | A ♦ | 1 | DECKEL |
| 23 | 00605 04222 | P ♦ | 1 | DECKEL |
| 24 | 00605 04223 | P ♦ | 1 | DECKEL |
| 25 | 00605 04224 | ♦ | 1 | SPANNROLLE |

♦ Rechts
♦ Links



D15

SPRINT
Ed. 87
Meccanica

1-1989

c.c. 1.3

TAV. 01.40

c.c. 32

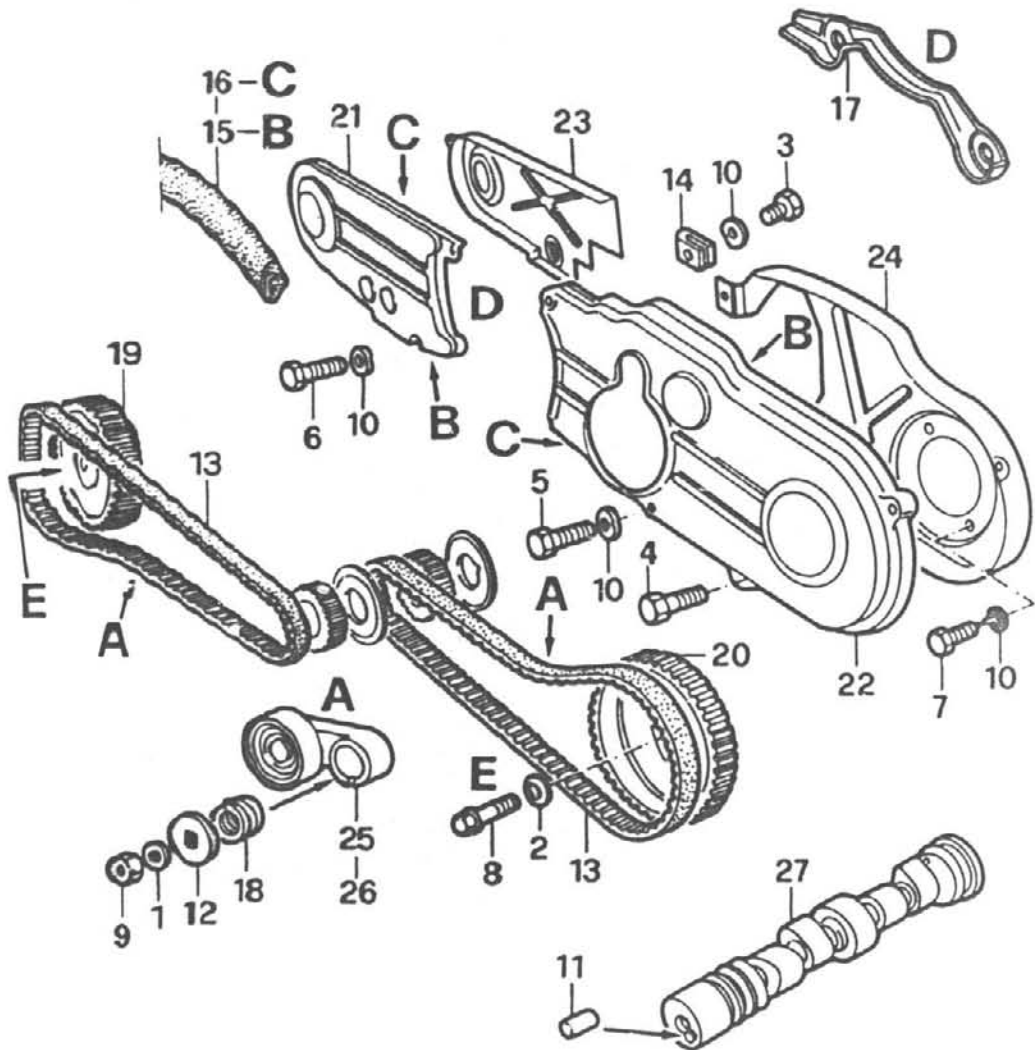

| pos. | TEILNUMMER | ref. | mg. benennung | ↑ |
|------|-------------|------|---------------|---|
| 26 | 00605 04225 | ◆ | 1 SPANNROLLE | |
| 27 | 00605 37313 | | 2 NOCKENWELLE | |

◆ Links

D16

SPRINT
Ed. 87
Meccanica

1-1989

I.E.

TAV. 01.40/5

c.c. 32

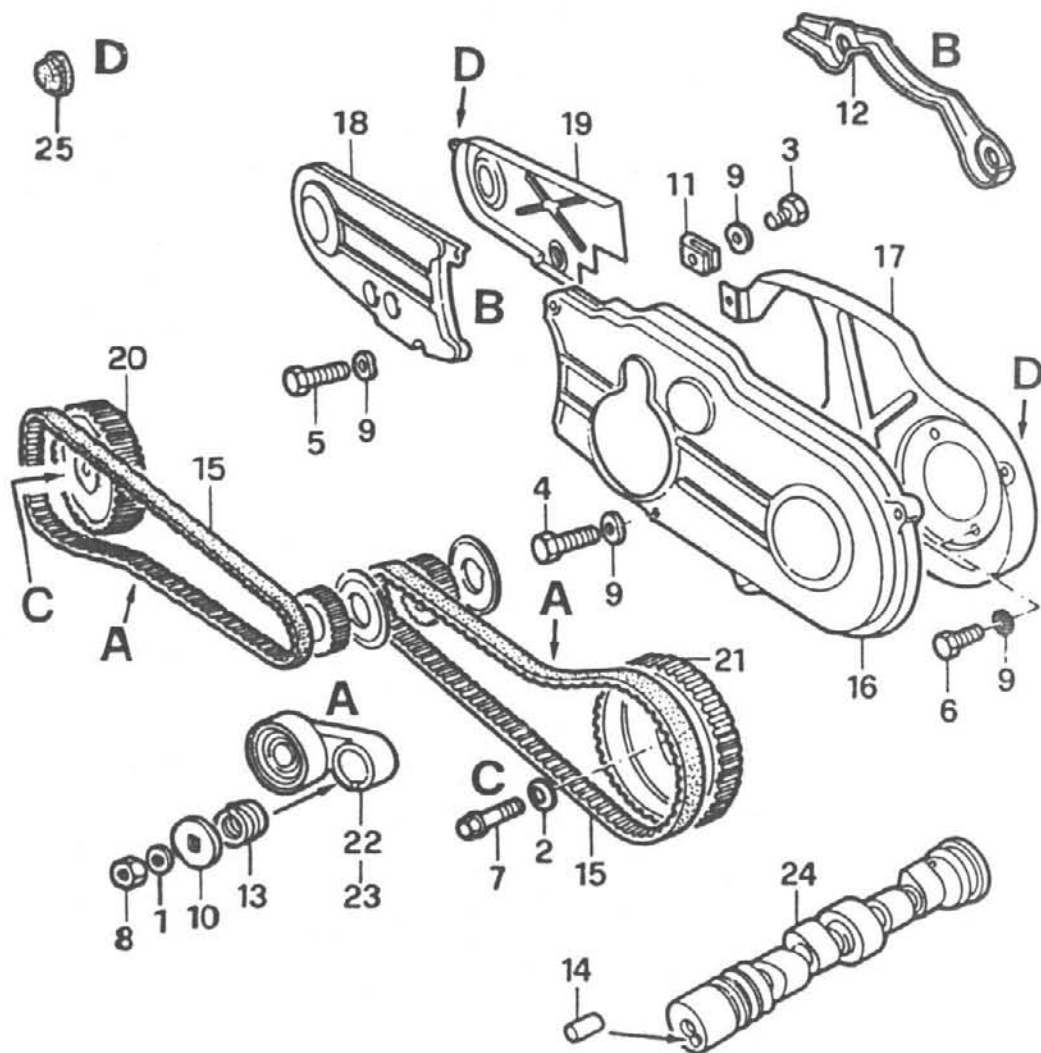

| pos. | TEILNUMMER | ref. | mg. | benennung |
|------|-------------------|------|-----|----------------|
| 1 | 02100 81437 00 00 | | 2 | SCHEIBE |
| 2 | 02100 81440 00 00 | | 2 | SCHEIBE |
| 3 | 00109 02211 | | 2 | SCHRAUBE |
| 4 | 00109 02411 | | 1 | SCHRAUBE |
| 5 | 00109 03211 | | 2 | SCHRAUBE |
| 6 | 00109 02121 | | 4 | SCHRAUBE |
| 7 | 00109 35721 | | 2 | SCHRAUBE |
| 8 | 00121 64711 | | 2 | MUTTER |
| 9 | 00126 01279 | | 8 | SCHEIBE |
| 10 | 00605 02922 | | 2 | SCHEIBE |
| 11 | 00605 03003 | | 4 | HALTER |
| 12 | 00605 03291 | | 1 | BLECHTEIL |
| 13 | 00605 03292 | | 2 | FEDER |
| 14 | 00605 03584 | | 2 | PASSTIFT |
| 15 | 00605 15034 | | 2 | RIEMEN |
| 16 | 00605 15055 | ◆ E | 1 | DECKEL |
| 17 | 00605 15051 | ◆ I | 1 | DECKEL |
| 18 | 00605 15054 | ◆ E | 1 | DECKEL |
| 19 | 00605 15052 | ◆ I | 1 | DECKEL |
| 20 | 00605 15036 | ◆ | 1 | RIEMENSCHLEIBE |
| 21 | 00605 15037 | ◆ | 1 | RIEMENSCHLEIBE |
| 22 | 00605 04224 | ◆ | 1 | SPANNROLLE |
| 23 | 00605 04225 | ◆ | 1 | SPANNROLLE |
| 24 | 00605 37868 | | 2 | NOCKENWELLE |
| 25 | 00605 15053 | | 2 | STOPFEN |

◆ Links
◆ Rechts

SPRINT 87
MECCANICA

9-1988

E

1

TAV 01.42/1

c.c. 1.7-c.c. 1.7 I.E.

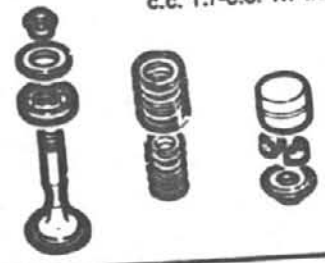

2

TAV 01.42

c.c. 1.3

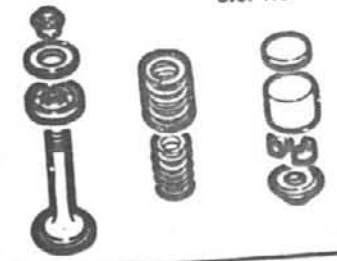

3

TAV 01.42

c.c. 1.3

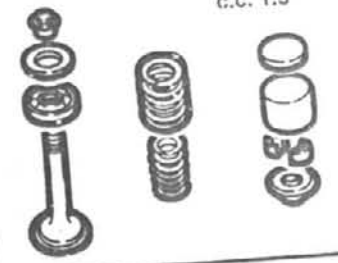

4

TAV

5

TAV

6

TAV 03.10



7

TAV

8

TAV

9

TAV

10

TAV

11

TAV

12

TAV

13

TAV

14

TAV

15

TAV

16

TAV

17

TAV

18

TAV

19

TAV

E₁

SPRINT
Ed. 87
Meccanica
1-1989

c.c. 1.7-c.c. 1.7 I.E.

TAV. 01.42/1

c.c. 32

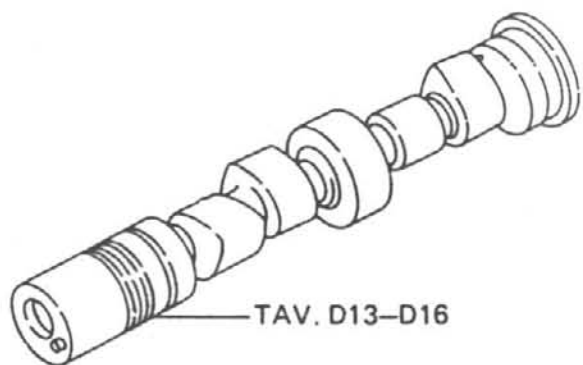
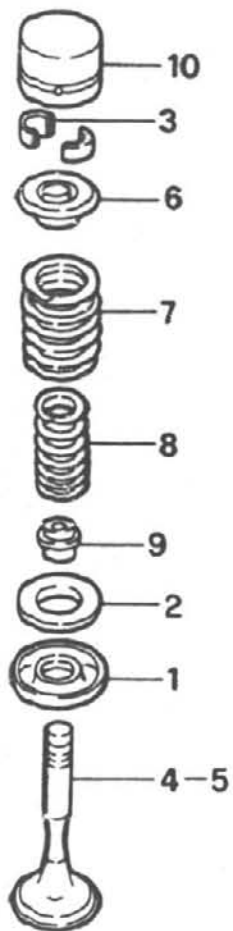

| pos. | TEILNUMMER | ref. | mg. benennung |
|------|-------------|------|-----------------|
| 1 | 00605 02911 | | 8 TELLER |
| 2 | 00605 02912 | | 8 SCHEIBE |
| 3 | 00605 03036 | | 16 HALBKEGEL |
| 4 | 00605 15042 | | 4 EINLASSVENTIL |
| 5 | 00605 15041 | | 4 AUSLASSVENTIL |
| 6 | 00605 15047 | | 8 TELLER |
| 7 | 00605 15044 | | 8 FEDER |
| 8 | 00605 15045 | | 8 FEDER |
| 9 | 00605 04110 | | 8 KAPPE |
| 10 | 00605 13941 | | 8 VENTILBECHER |

E₂

SPRINT
Ed. 87
Meccanica
1-1989

c.c. 1.3

TAV 01.42

c.c. 32

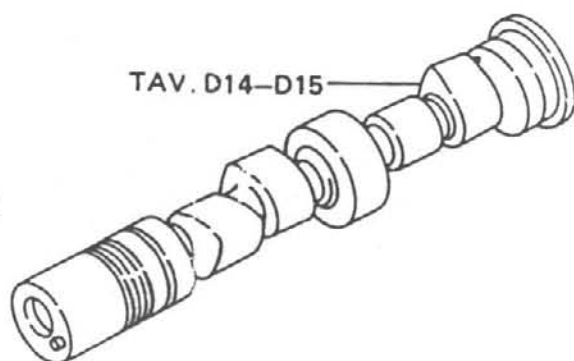
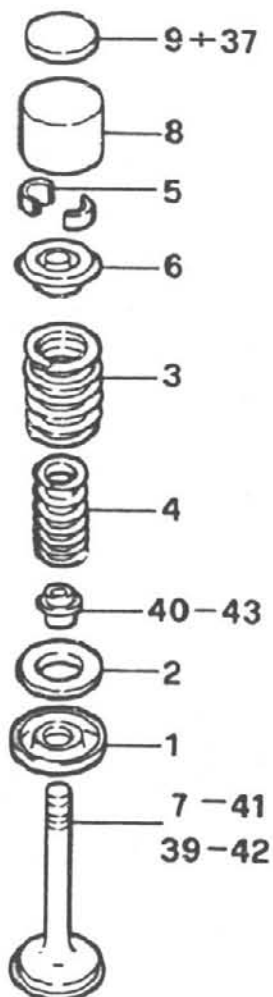

| pos. | TEILNUMMER | ref. | mg. benennung |
|------|-------------|------|--------------------|
| 1 | 00605 32911 | | 8 TELLER |
| 2 | 00605 02912 | | 8 SCHEIBE |
| 3 | 00605 02958 | | 8 FEDER |
| 4 | 00605 03101 | | 8 FEDER |
| 5 | 00605 03036 | | 16 HALBKEGEL |
| 6 | 00605 03039 | | 8 TELLER |
| 7 | 00605 04784 | | 4 AUSLASSVENTIL |
| 8 | 00605 03405 | | 8 VENTILBECHER |
| 9 | 00605 03408 | | BEILAGSCH. 3,25 MM |
| 10 | 00605 03409 | | BEILAGSCH. 3,30 MM |
| 11 | 00605 03410 | | BEILAGSCH. 3,35 MM |
| 12 | 00605 03411 | | BEILAGSCH. 3,40 MM |
| 13 | 00605 03412 | | BEILAGSCH. 3,45 MM |
| 14 | 00605 03413 | | BEILAGSCH. 3,50 MM |
| 15 | 00605 03414 | | BEILAGSCH. 3,55 MM |
| 16 | 00605 03415 | | BEILAGSCH. 3,60 MM |
| 17 | 00605 03416 | | BEILAGSCH. 3,65 MM |
| 18 | 00605 03417 | | BEILAGSCH. 3,70 MM |
| 19 | 00605 03418 | | BEILAGSCH. 3,75 MM |
| 20 | 00605 03419 | | BEILAGSCH. 3,80 MM |
| 21 | 00605 03420 | | BEILAGSCH. 3,85 MM |
| 22 | 00605 03421 | | BEILAGSCH. 3,90 MM |
| 23 | 00605 03422 | | BEILAGSCH. 3,95 MM |
| 24 | 00605 03423 | | BEILAGSCH. 4,00 MM |
| 25 | 00605 03424 | | BEILAGSCH. 4,05 MM |



E₃

SPRINT
Ed. 87
Meccanica
1-1989

c.c. 1.3

TAV. 01.42

c.c. 32

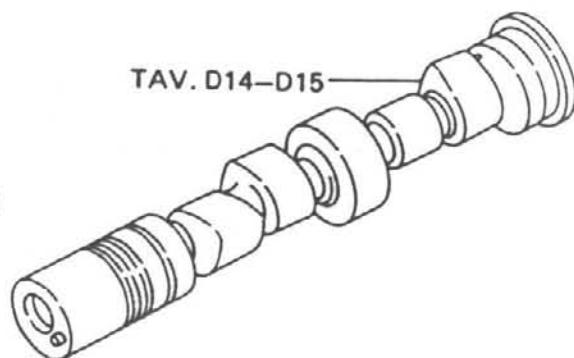
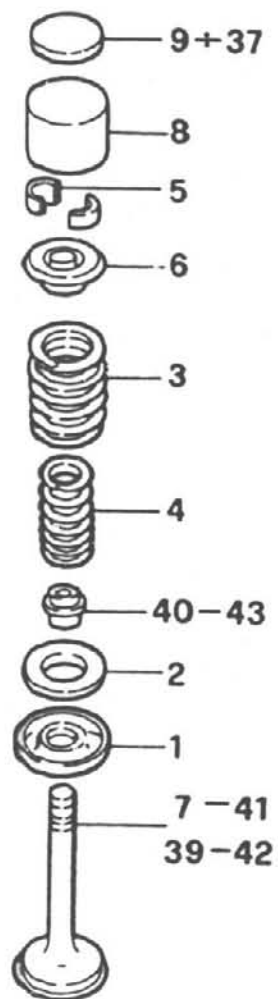

| pos. | TEILNUMMER | ref. | mg. benennung | ↑ |
|------|-------------|------|--------------------|---|
| 26 | 00605 03425 | | BEILAGSCH. 4,10 MM | |
| 27 | 00605 03426 | | BEILAGSCH. 4,15 MM | |
| 28 | 00605 03427 | | BEILAGSCH. 4,20 MM | |
| 29 | 00605 03428 | | BEILAGSCH. 4,25 MM | |
| 30 | 00605 03429 | | BEILAGSCH. 4,30 MM | |
| 31 | 00605 03430 | | BEILAGSCH. 4,35 MM | |
| 32 | 00605 03431 | | BEILAGSCH. 4,40 MM | |
| 33 | 00605 03432 | | BEILAGSCH. 4,45 MM | |
| 34 | 00605 03433 | | BEILAGSCH. 4,50 MM | |
| 35 | 00605 03434 | | BEILAGSCH. 4,55 MM | |
| 36 | 00605 03435 | | BEILAGSCH. 4,60 MM | |
| 37 | 00605 03436 | | BEILAGSCH. 4,65 MM | |
| 39 | 00605 04783 | | 4 EINLASSVENTIL | |
| 40 | 00605 35949 | | 8 KAPPE | |
| 41 | 00605 03993 | ■ | 4 AUSLASSVENTIL | |
| 42 | 00605 06548 | ■ | 4 EINLASSVENTIL | |
| 43 | 00605 04110 | ■ | 8 KAPPE | |

E₆

SPRINT
Ed. 87
Meccanica
1-1989

TAV. 03.10

c.c. 32

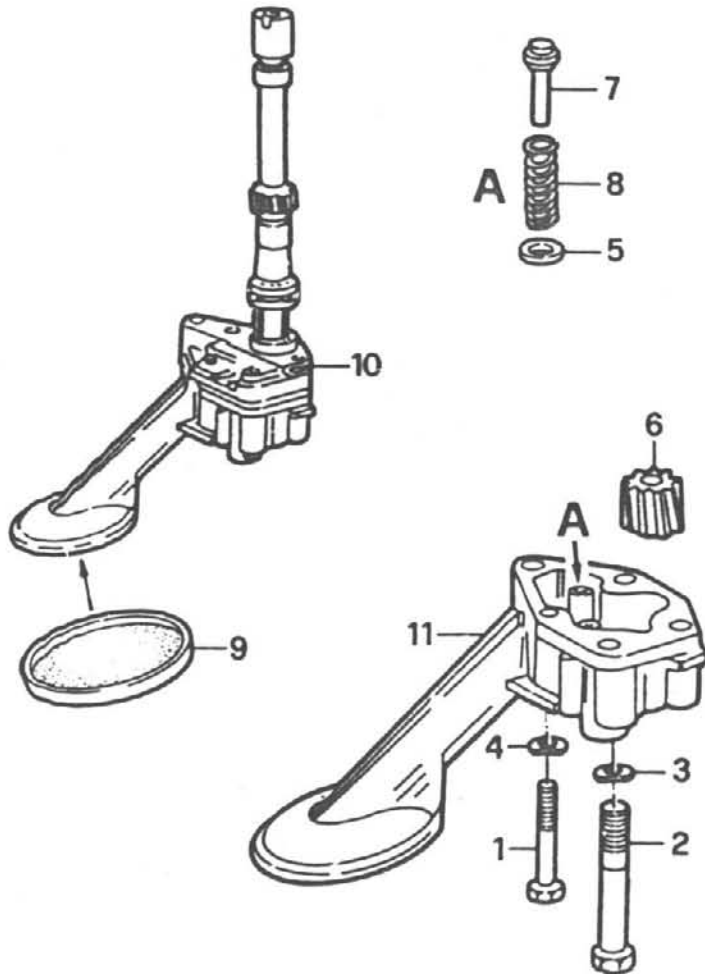

| pos. | TEILNUMMER | ref. | mg. benennung |
|------|-------------|------|----------------|
| 1 | 00109 03723 | 2 | SCHRAUBE |
| 2 | 02100 20187 | 3 | SCHRAUBE |
| 3 | 00126 01370 | 3 | SCHEIBE |
| 4 | 00126 01279 | 2 | SCHEIBE |
| 5 | 00605 02907 | 1 | SCHEIBE |
| 6 | 00605 03168 | 1 | ZAHNRAD |
| 7 | 00605 03170 | 1 | VENTIL |
| 8 | 00605 03172 | 1 | SPIRALFEDER |
| 9 | 00605 03309 | 1 | SIEB |
| 10 | 00605 04357 | 1 | OELPUMPE |
| 11 | 00605 04358 | 1 | PUMPENGEHAEUSE |

F

1 TAV 02.04

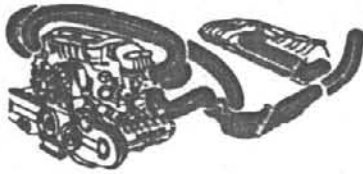

2 TAV 02.03



3 TAV 02.03/1

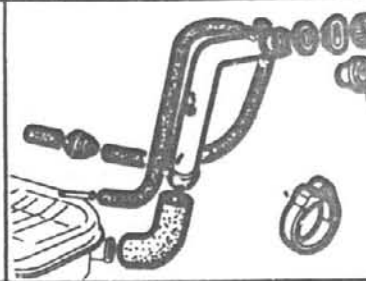

4 TAV

5 TAV 02.11

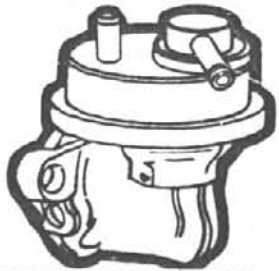

6 TAV

7 TAV 02.11/4

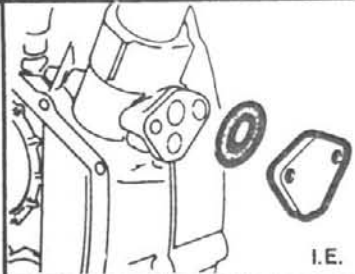

8 TAV 02.04/5

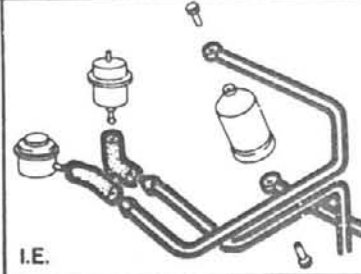

9 TAV 02.11/6

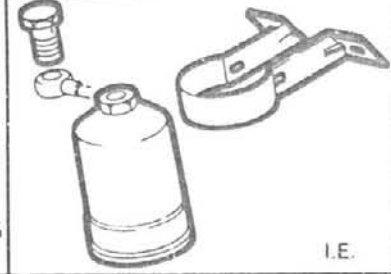

10 TAV 02.11/5

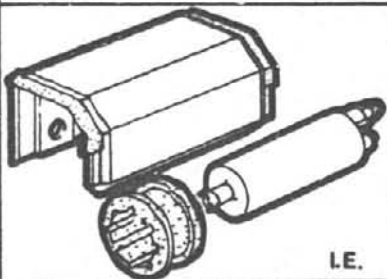

11 TAV 02.08

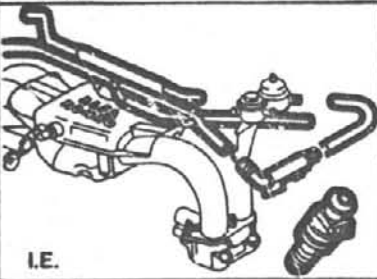

12 TAV 02.06/1

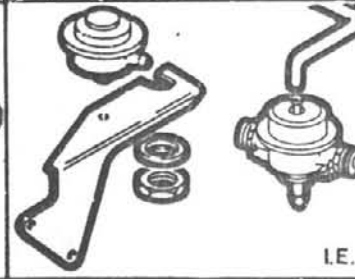

13 TAV 02.73/5

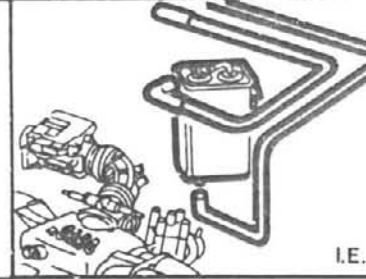

14 TAV 02.03/7

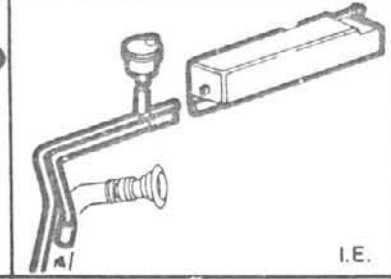

15 TAV 02.03/5

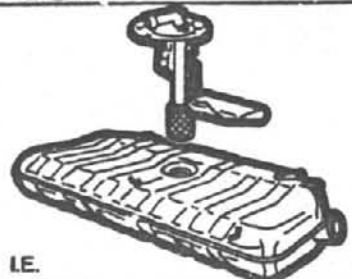

16 TAV 02.03/8

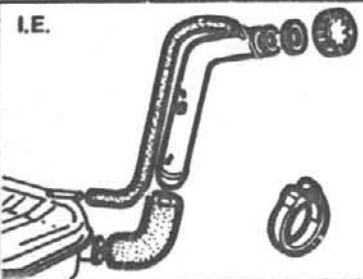

17 TAV

18 TAV

19 TAV

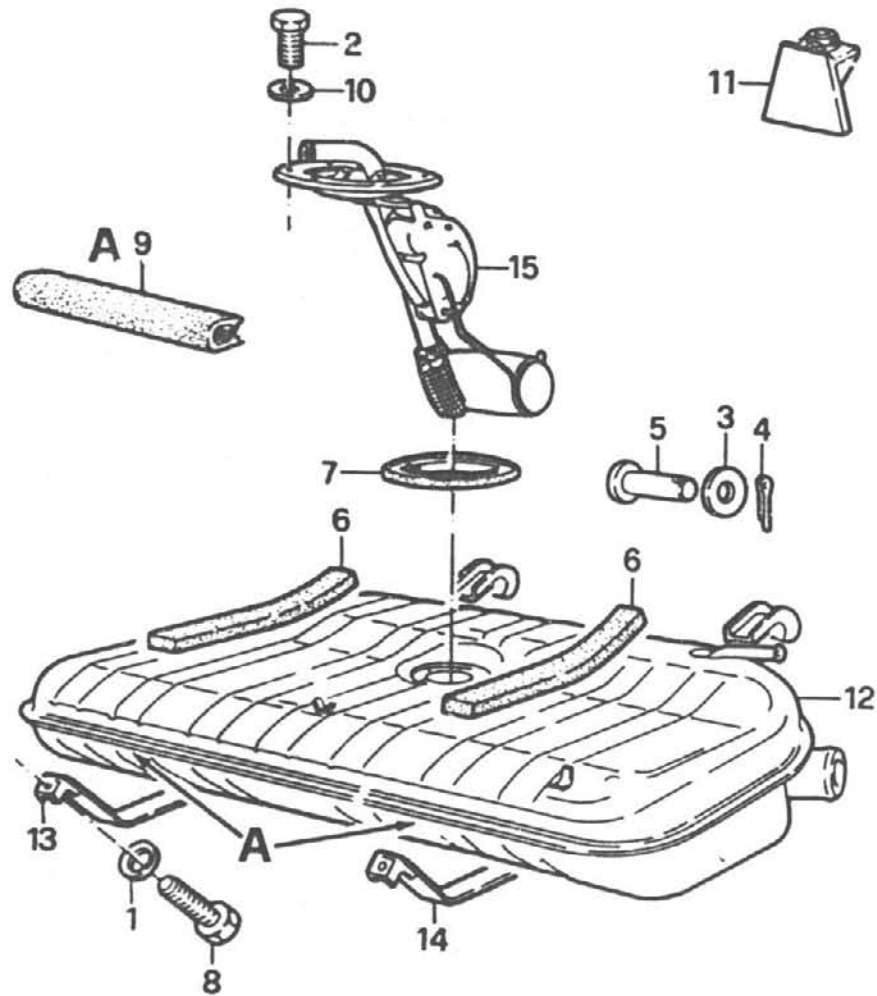

| pos. | TEILNUMMER | ref. | mg. benennung |
|------|-------------------|------|---------------|
| 1 | 02100 31434 00 00 | 2 | SCHEIBE |
| 2 | 00104 44621 | 6 | SCHRAUBE |
| 3 | 02145 16664 00 00 | 2 | SCHEIBE |
| 4 | 00107 66800 | 2 | SPLINT |
| 5 | 00100 41513 | 2 | BOLZEN |
| 6 | 00605 02934 | 2 | FILZ |
| 7 | 00605 02961 | 1 | DICHTUNG |
| 8 | 00605 03200 | 2 | SCHRAUBE |
| 9 | 12591 60000 00 00 | 1 | DICHTUNG |
| 10 | 00605 03683 | 6 | SCHEIBE |
| 11 | 00605 04180 | 1 | ABSTANDSTUECK |
| 12 | 00605 04188 | 1 | BEHALTER |
| 13 | 00605 04238 | 1 | FANGBAND |
| 14 | 00605 04307 | 1 | FANGBAND |
| 15 | 00605 04327 | 1 | GEBER |

F₃

SPRINT
Ed. 87
Meccanica

1-1989

TAV. 02.03/1

c.c. 32

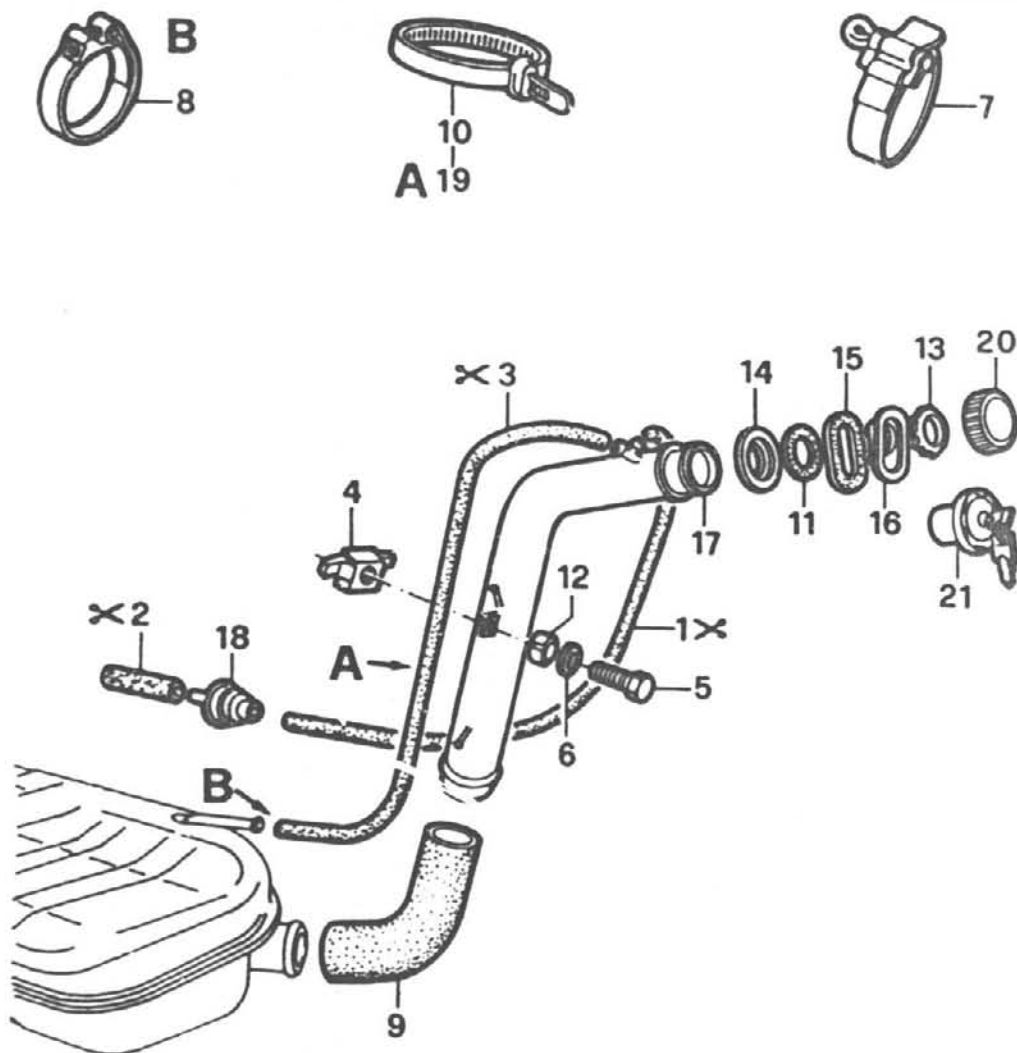

| pos. | TEILNUMMER | ref. | mg. benennung |
|------|-------------------|------|---------------|
| 1 | 00670 99987 | | ROHR |
| 2 | 00323 52004 52 14 | | ROHR |
| 3 | 00670 99974 | | ROHR |
| 4 | 00146 48790 | | 1 MUTTER |
| 5 | 00109 02421 | | 1 SCHRAUBE |
| 6 | 02142 16673 00 00 | | 1 SCHEIBE |
| 7 | 00121 68190 | | 2 SCHELLE |
| 8 | 00131 00590 | | 1 SCHELLE |
| 9 | 00605 02957 | | 1 ROHR |
| 10 | 00605 01344 | | 2 SCHELLE |
| 11 | 00605 17693 | | 1 DICHTUNG |
| 12 | 00605 17699 | | 1 RING |
| 13 | 00605 17700 | | 1 RINGMUTTER |
| 14 | 00605 17703 | | 1 RINGMUTTER |
| 15 | 00605 17704 | | 1 DICHTUNG |
| 16 | 00605 17705 | | 1 FLANSCH |
| 17 | 00605 18443 | | 1 ROHR |
| 18 | 00605 22477 | | 1 VENTIL |
| 19 | 12716 00000 00 00 | | 1 SCHELLF |
| 20 | 00605 36764 | | 1 STOPFEN |
| 21 | 00607 49698 | | 1 STOPFEN |

F₅

SPRINT
Ed. 87
Meccanica

1-1989

TAV. 02.11

c.c. 32

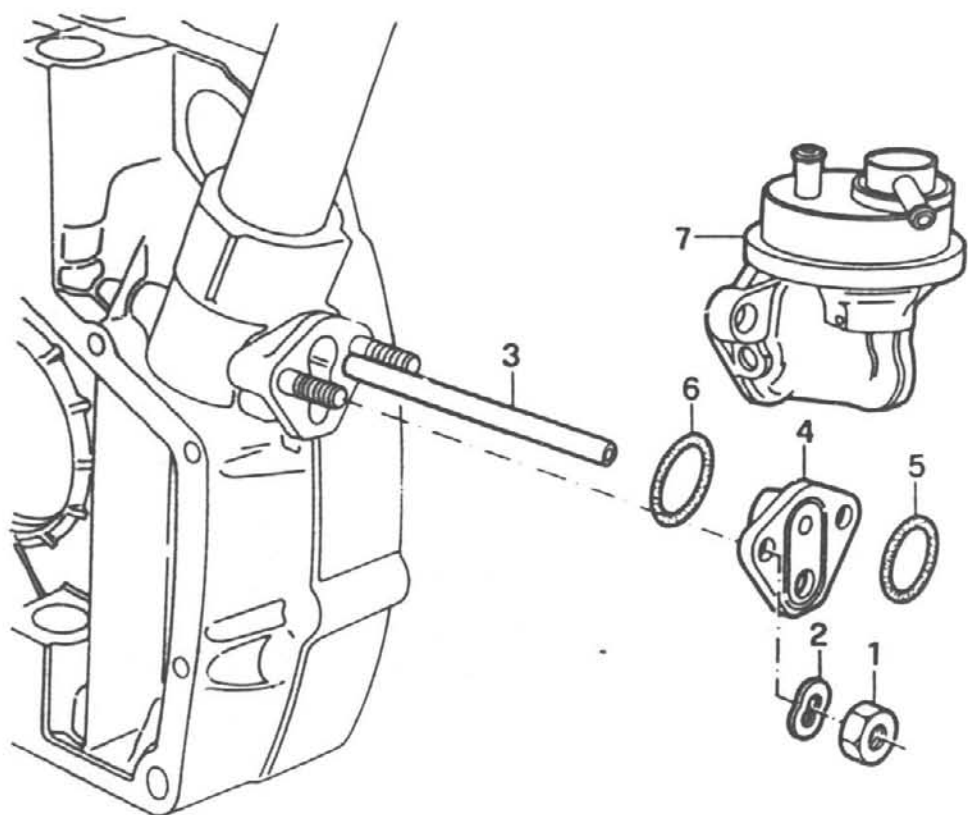

| pos. | TEILNUMMER | ref. | mg. benennung |
|------|-------------|------|-------------------|
| 1 | 00161 00811 | | 2 MUTTER |
| 2 | 00126 01379 | | 2 SCHEIBE |
| 3 | 00605 03083 | | 1 DRUCKSTANGE |
| 4 | 00605 03084 | | 1 ISOLIERSTOFF |
| 5 | 00605 03085 | | 1 DICHTUNG |
| 6 | 00605 03086 | | 1 DICHTUNG |
| 7 | 00605 04214 | | 1 KRAFTSTOFFPUMPE |

F7

SPRINT
Ed. 87
Meccanica

1-1989

I.E.

TAV. 02.11/4

c.c. 32

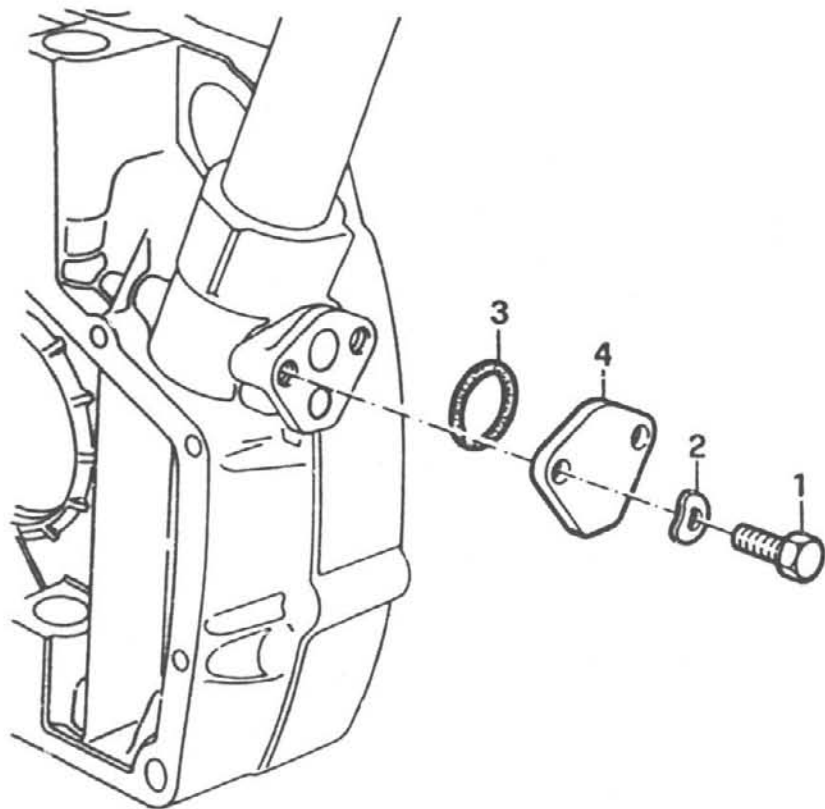

| pos. | TEILNUMMER | ref. | mg. benennung |
|------|-------------|------|---------------|
| 1 | 00160 43221 | | 2 SCHRAUBE |
| 2 | 00126 01379 | | 2 SCHEIBE |
| 3 | 00605 03086 | | 1 DICHTUNG |
| 4 | 00605 21557 | | 1 DECKEL |

F₉

SPRINT
Ed. 87
Meccanica

1-1989

I.E.

TAV 02.11/6

c.c. 32

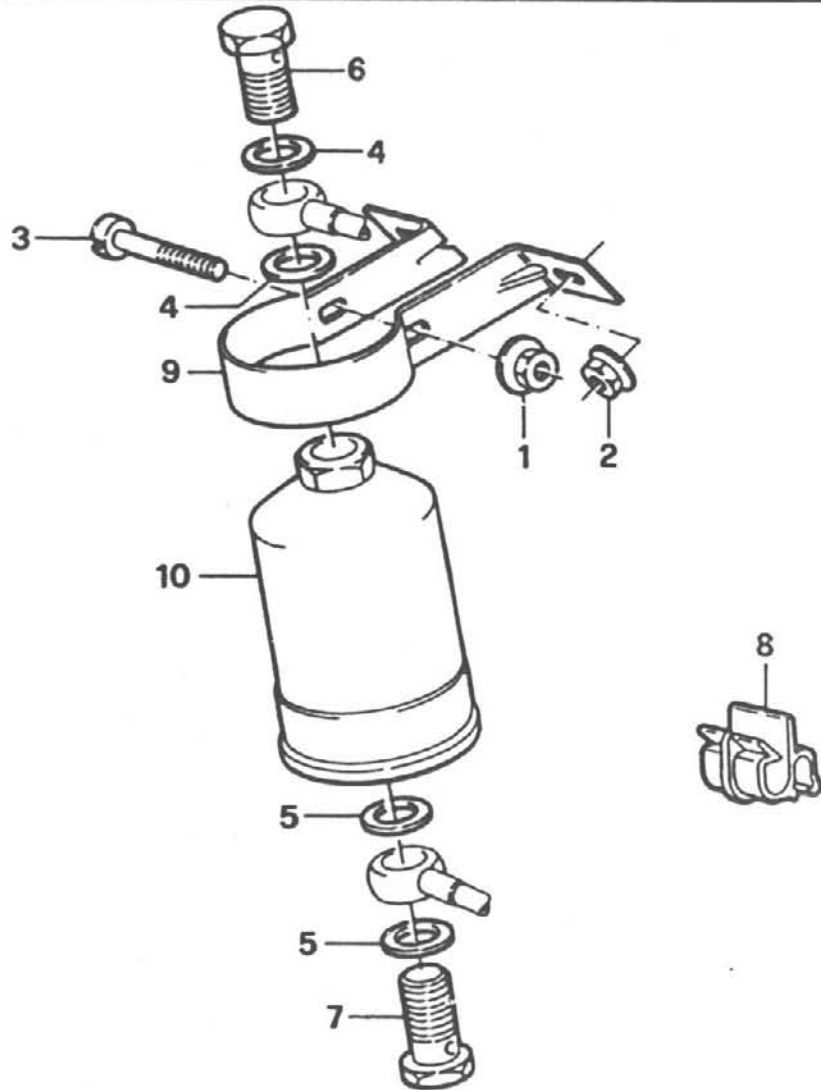

| pos. | TEILNUMMER | ref. | mg. benennung |
|------|-------------------|------|---------------|
| 1 | 00140 39511 | | 1 MUTTER |
| 2 | 00140 84211 | | 2 MUTTER |
| 3 | 00103 90511 | | 1 SCHRAUBE |
| 4 | 00102 61060 | | 2 DICHTUNG |
| 5 | 00102 61160 | | 2 DICHTUNG |
| 6 | 00101 81711 | | 1 VERTEILER |
| 7 | 02370 31483 00 00 | | 1 VERTEILER |
| 8 | 00605 07004 | | 1 KLAMMER |
| 9 | 00605 25049 | | 1 SCHELLE |
| 10 | 00824 16870 | | 1 FILTER |

F₁₀

SPRINT
Ed. 87
Meccanica

1-1989

I.E.

TAV. 02.11/5

c.c. 32

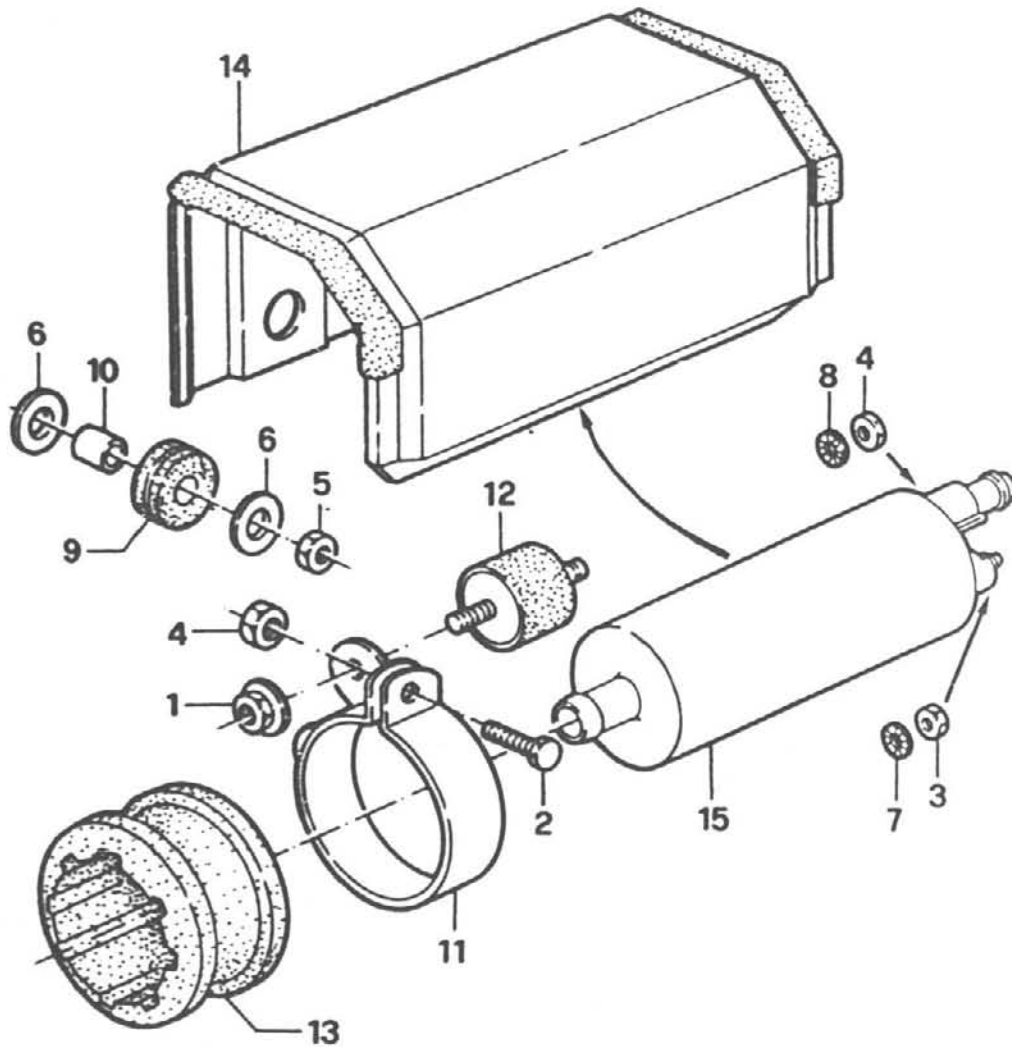

| pos. | TEILNUMMER | ref. | mg. benennung |
|------|-------------------|------|------------------|
| 1 | 00140 84211 | | 2 MUTTER |
| 2 | 00109 78011 | | 1 SCHRAUBE |
| 3 | 02125 15025 00 00 | | 1 MUTTER |
| 4 | 00158 96411 | | 2 MUTTER |
| 5 | 00158 96211 | | 4 MUTTER |
| 6 | 00135 77911 | | 8 SCHEIBE |
| 7 | 00106 15279 | | 1 SCHEIBE |
| 8 | 00106 15379 | | 1 SCHEIBE |
| 9 | 00605 02940 | | 4 ZWISCHENSTUECK |
| 10 | 00605 02967 | | 4 ABSTANDSTUECK |
| 11 | 00605 22648 | | 1 SCHELLE |
| 12 | 00605 07128 | | 1 LAGERUNG |
| 13 | 00605 24670 | | 1 RING |
| 14 | 00605 37605 | | 1 DECKEL |
| 15 | 00605 37611 | | 1 PUMPE |

F₁₁

SPRINT
Ed. 87
Meccanica

1-1989

I.E.

TAV. 02.06

c.c. 32

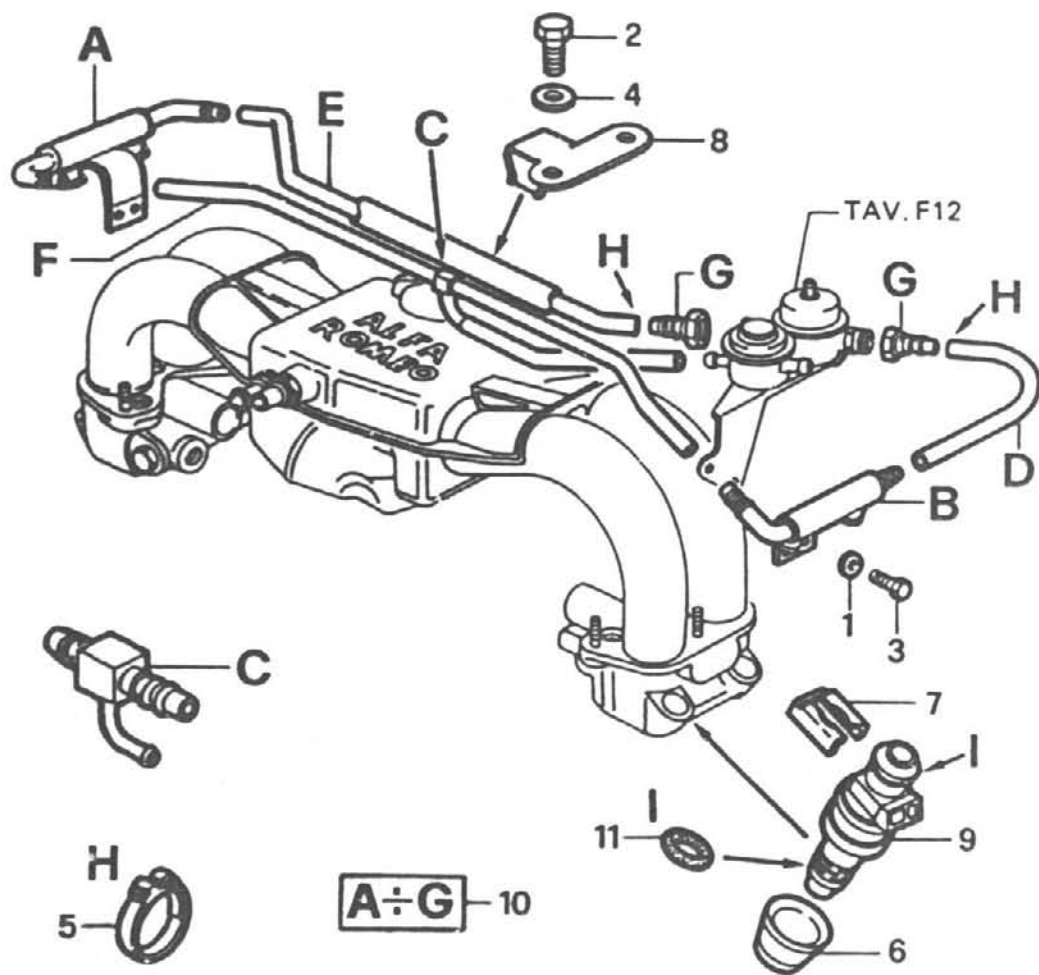

| pos. | TEILNUMMER | ref. | mg. | benennung |
|------|-------------------|------|-----|----------------|
| 1 | 02100 81408 00 00 | | 4 | SCHEIBE |
| 2 | 00109 79411 | | 2 | SCHRAUBE |
| 3 | 00143 05721 | | 4 | SCHRAUBE |
| 4 | 02105 81408 00 00 | | 2 | SCHEIBE |
| 5 | 00607 07716 | | 2 | SCHELLE |
| 6 | 00605 24529 | | 4 | DICHTUNG |
| 7 | 00605 07555 | | 4 | FEDER |
| 8 | 00605 25089 | | 1 | BUEGEL |
| 9 | 00605 37527 | | 4 | EINSPRITZDUESE |
| 10 | 00605 38012 | | 1 | AUSPUFFANLAGE |
| 11 | 00607 54003 | | 8 | ABDICHTUNG |

F12

SPRINT
Ed. 87
Meccanica

1-1989

I.E.

TAV. 02.06/1

c.c. 32

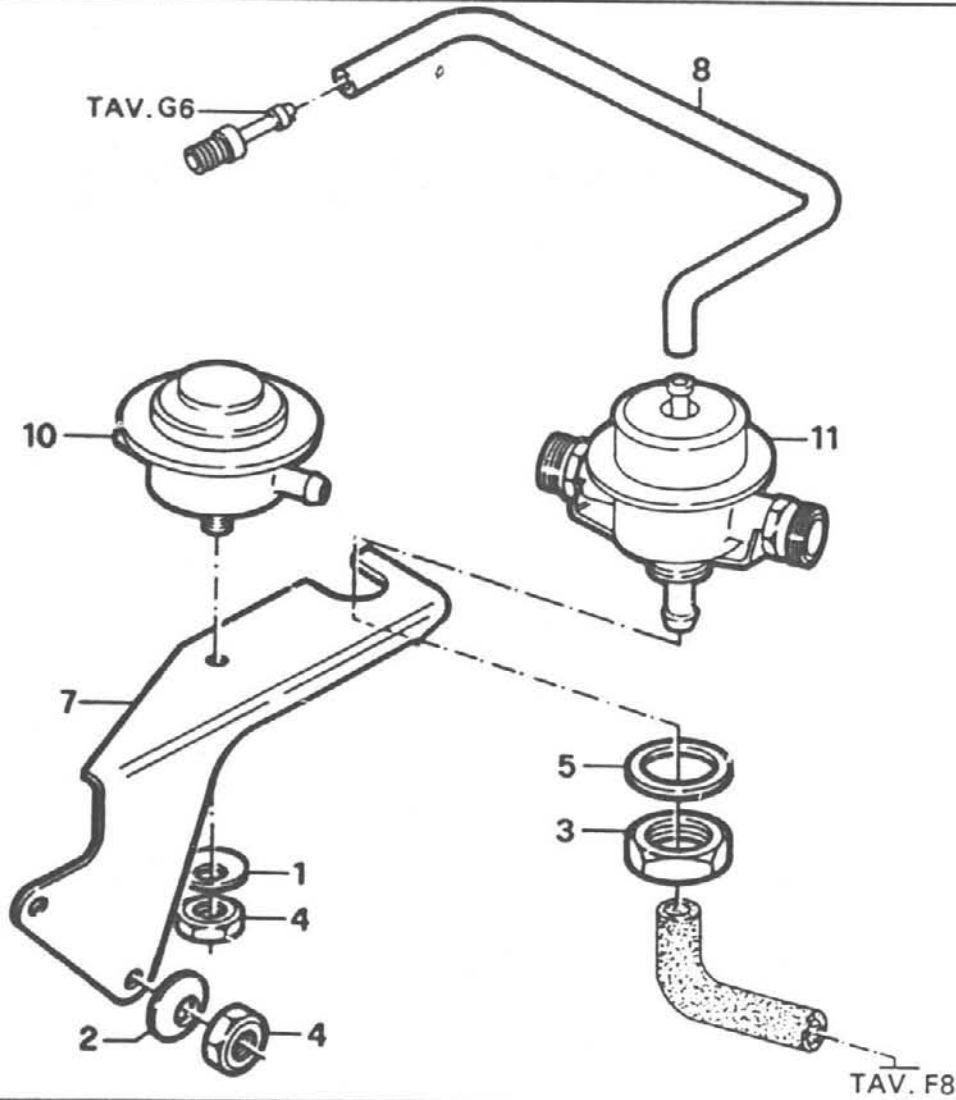

| pos. | TEILNUMMER | ref. | mg. benennung |
|------|-------------------|------|-----------------------|
| 1 | 02100 81405 00 00 | | 1 SCHEIBE |
| 2 | 02105 81408 00 00 | | 2 SCHEIBE |
| 3 | 00107 91411 | | 1 MUTTER |
| 4 | 00161 00811 | | 2 MUTTER |
| 5 | 00126 01779 | | 1 SCHEIBE |
| 7 | 00605 24520 | | 1 BUEGEL |
| 8 | 00605 25072 | | 1 ROEHRCHEN |
| 10 | 00605 07656 | | 1 SCHWINGUNGSDAEMPFER |
| 11 | 00605 37528 | | 1 REGLERGRUPPE |

F13

SPRINT
Ed. 87
Meccanica
1-1989

I.E.

TAV. 02.73/5

c.c. 32

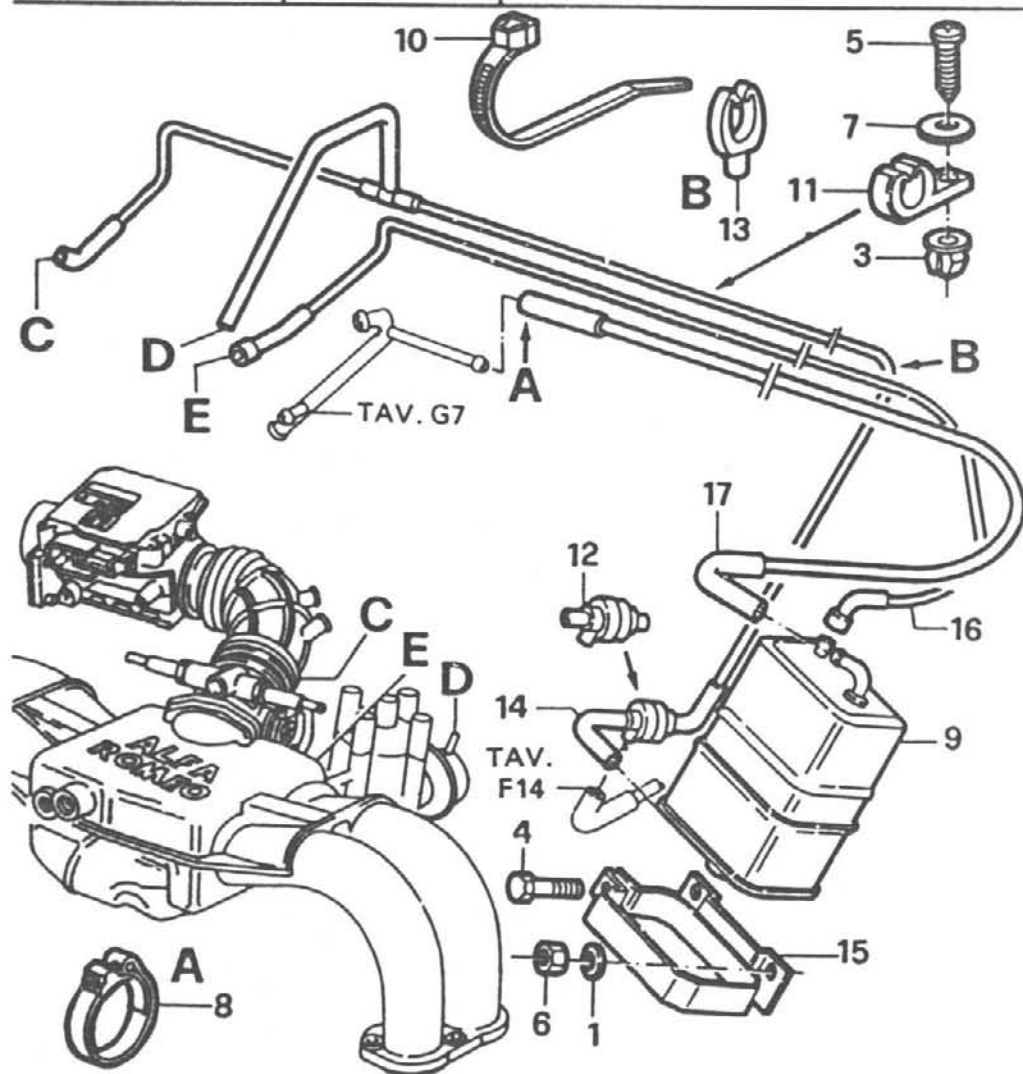

| pos. | TEILNUMMER | ref. | mg. | benennung |
|------|-------------------|------|-----|----------------|
| 1 | 02100 81408 00 00 | | 4 | SCHEIBE |
| 3 | 00141 15780 | | 1 | ZWISCHENSTUECK |
| 4 | 00109 02211 | | 5 | SCHRAUBE |
| 5 | 00156 44201 | | 1 | SCHRAUBE |
| 6 | 00158 96211 | | 1 | MUTTER |
| 7 | 00126 01079 | | 1 | SCHEIBE |
| 8 | 00131 00790 | | 1 | SHELLE |
| 9 | 00605 18165 | | 1 | FILTER |
| 10 | 12716 00000 00 00 | | 4 | SHELLE |
| 11 | 00605 25170 | | 1 | KLAMMER |
| 12 | 00605 31065 | | 1 | VENTIL |
| 13 | 00605 14976 | | 1 | KLAMMER |
| 14 | 00605 38675 | | 1 | ROHR |
| 15 | 00605 38456 | | 1 | HALTER |
| 16 | 00605 38631 | | 1 | ROHR |
| 17 | 00605 38677 | | 1 | ROHR |

F14

SPRINT
Ed. 87
Meccanica
1-1989

I.E.

TAV. 02.03/7

c.c. 32

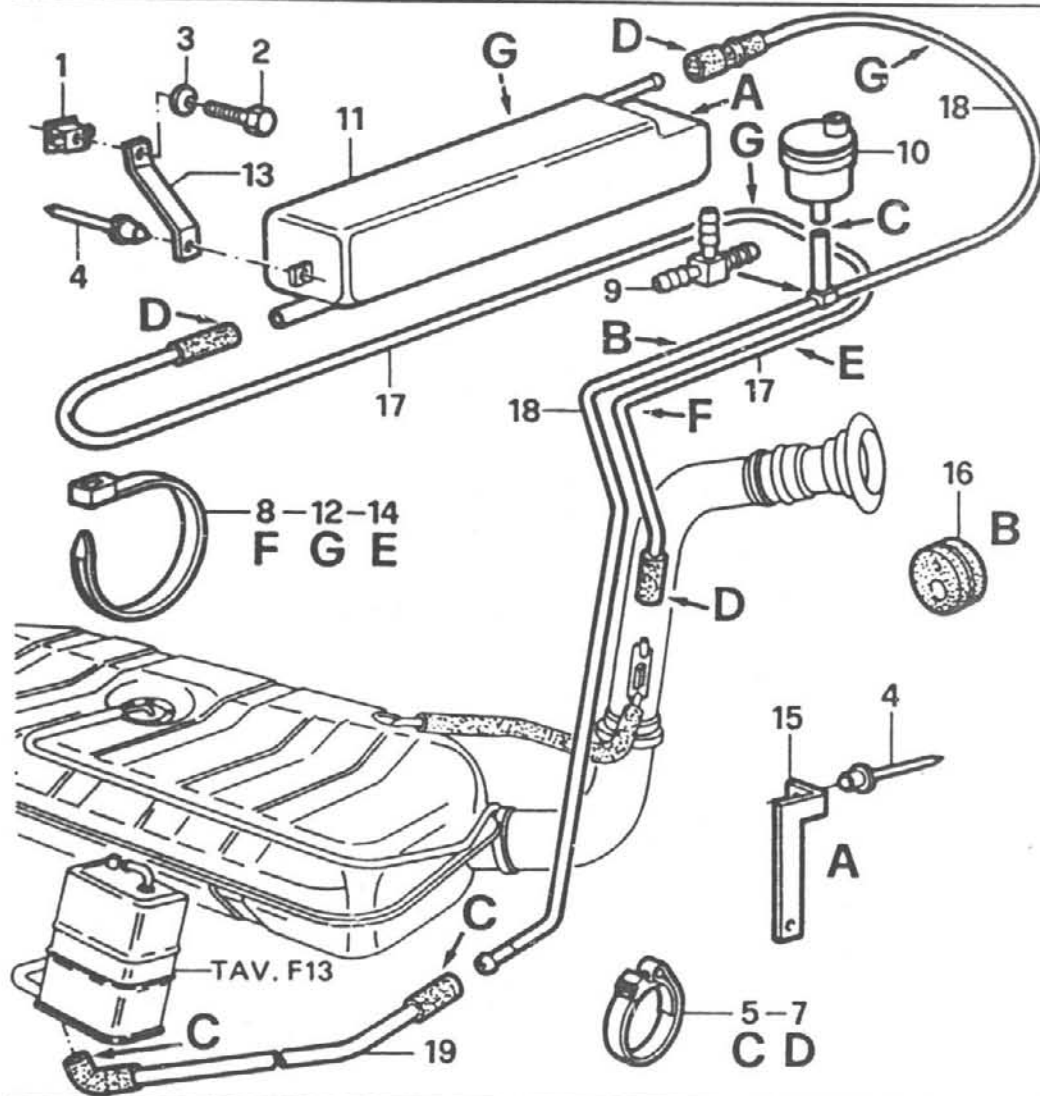

| pos. | TEILNUMMER | ref. | mg. benennung |
|------|-------------------|------|----------------------|
| 1 | 00146 48290 | | 1 MUTTER |
| 2 | 00161 32311 | | 1 SCHRAUBE |
| 3 | 02105 81408 00 00 | | 1 SCHEIBE |
| 4 | 00146 42594 | | 2 NIET |
| 5 | 00131 00290 | | 1 SCHELLE |
| 7 | 00131 00990 | | 3 SCHELLE |
| 8 | 00605 01344 | | 3 SCHELLE |
| 9 | 00605 17476 | | 1 VERTEILER |
| 10 | 00605 07127 | | 1 VENTIL |
| 11 | 00605 23696 | | 1 SCHALLDAEMPFER |
| 12 | 00605 23701 | | 2 HALTER |
| 13 | 00605 23798 | | 1 SCHELLE |
| 14 | 12716 00000 00 00 | | 1 SCHELLE |
| 15 | 00605 24273 | | 1 HALTER |
| 16 | 00605 25356 | | 1 KABELDURCHFUEHRUNG |
| 17 | 00605 38648 | | 1 ROHR |
| 18 | 00605 38565 | | 1 ROHR |
| 19 | 00605 38507 | | 1 ROHR |

F15

SPRINT
Ed. 87
Meccanica

1-1989

I.E.

TAV. 02.03/5

c.c. 32

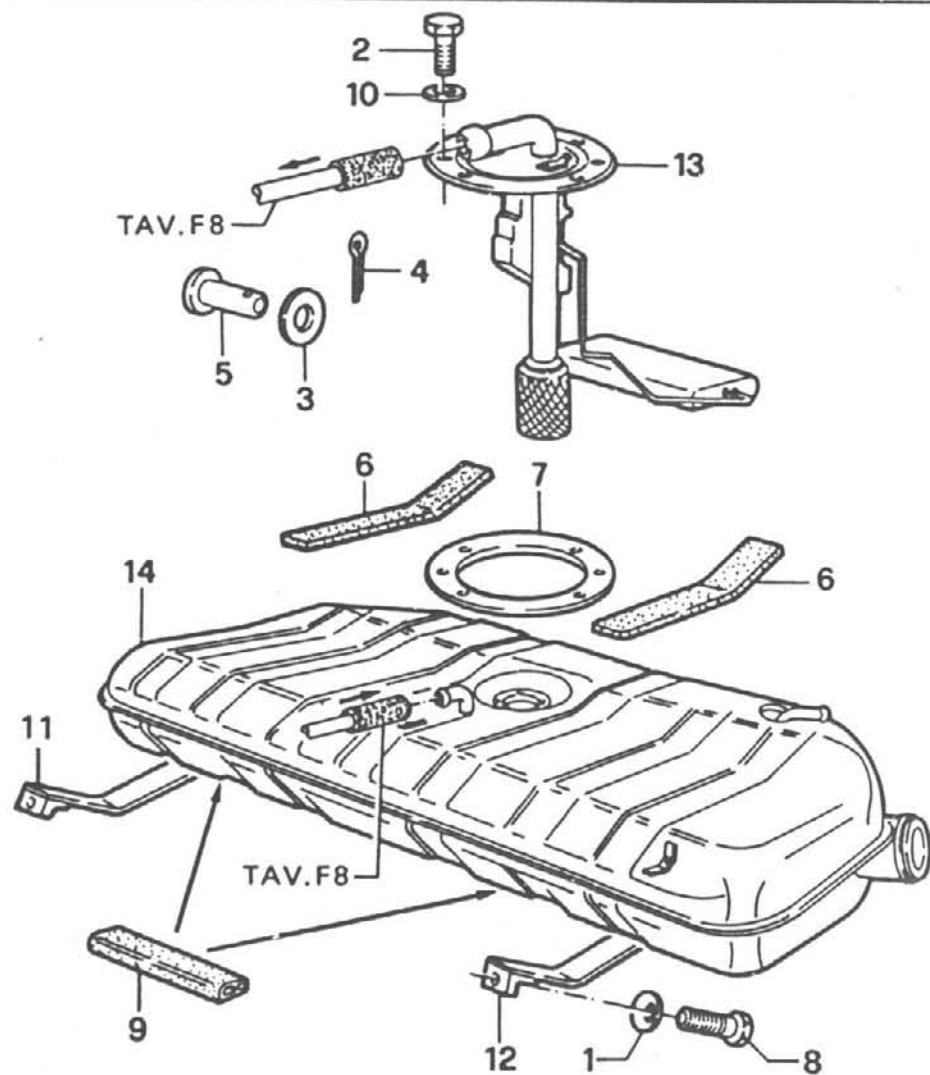

| pos. | TEILNUMMER | ref. | mg. | benennung |
|------|-------------------|------|-----|-----------|
| 1 | 02100 81434 00 00 | | 2 | SCHEIBE |
| 2 | 00104 44621 | | 6 | SCHRAUBE |
| 3 | 02145 16664 00 00 | | 2 | SCHEIBE |
| 4 | 00107 66800 | | 2 | SPLINT |
| 5 | 00100 41513 | | 2 | BOLZEN |
| 6 | 00605 02934 | | 2 | FILZ |
| 7 | 00605 02961 | | 1 | DICHTUNG |
| 8 | 00605 03200 | | 2 | SCHRAUBE |
| 9 | 12591 60000 00 00 | | 1 | DICHTUNG |
| 10 | 00605 03683 | | 6 | SCHEIBE |
| 11 | 00605 04238 | | 1 | FANGBAND |
| 12 | 00605 04307 | | 1 | FANGBAND |
| 13 | 00605 39799 | | 1 | GEBER |
| 14 | 00965 86827 | | 1 | BEHAELTER |

F₁₆

SPRINT
Ed. 87
Meccanica

1-1989

I.E.

TAV. 02.03/6

c.c. 32

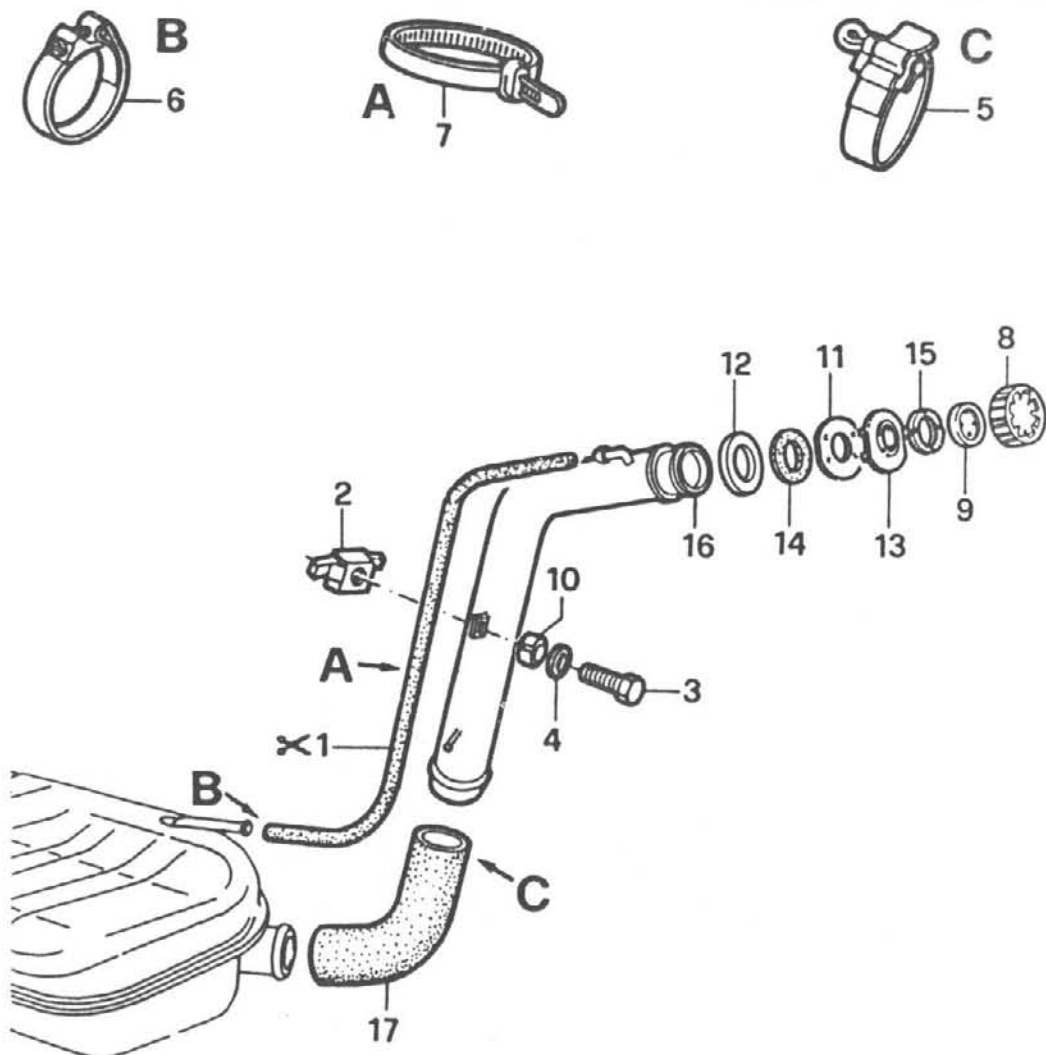

| pos. | TEILNUMMER | ref. | mg. benennung |
|------|-------------------|------|---------------|
| 1 | 00670 99974 | | ROHR |
| 2 | 00146 48790 | 1 | MUTTER |
| 3 | 00109 02421 | 1 | SCHRAUBE |
| 4 | 02142 16673 00 00 | 1 | SCHEIBE |
| 5 | 00121 68190 | 2 | SCHELLE |
| 6 | 00131 00590 | 1 | ROHR |
| 7 | 00605 01344 | 2 | SCHELLE |
| 8 | 00605 17102 | 1 | STOPFEN |
| 9 | 00605 17421 | 1 | DICHTUNG |
| 10 | 00605 17699 | 1 | RING |
| 11 | 00605 24623 | 1 | DICHTUNG |
| 12 | 00605 24624 | 1 | RINGMUTTER |
| 13 | 00605 24625 | 1 | FLANSCH |
| 14 | 00605 24626 | 1 | DICHTUNG |
| 15 | 00605 24647 | 1 | RINGMUTTER |
| 16 | 00605 38419 | 1 | ROHR |
| 17 | 00605 02957 | 1 | ROHR |

G

1

TAV 02.70



2

TAV 02.70/2

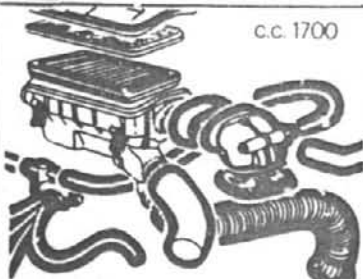

3

TAV 02.70/2

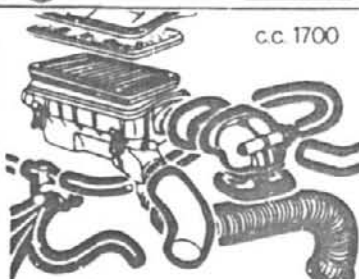

4

TAV 02.70/1

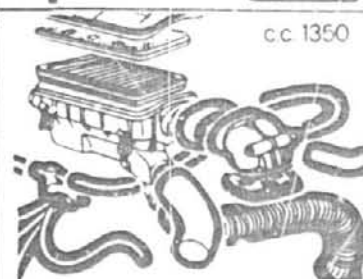

5

TAV 02.70/1

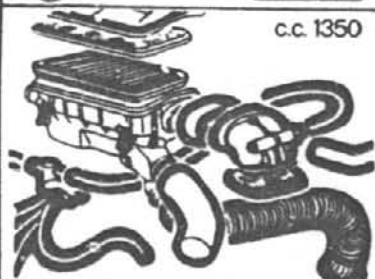

6

TAV 02.35

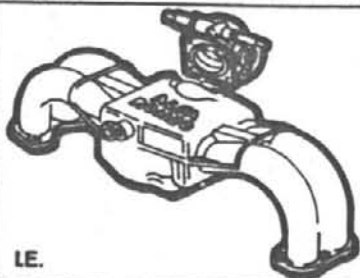

7

TAV 02.33

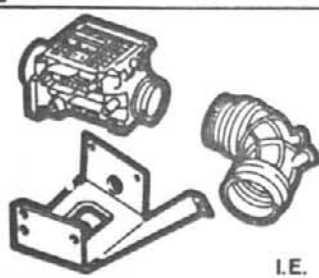

8

TAV 02.70/5

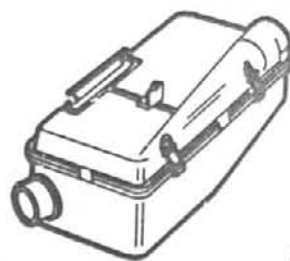

9

TAV 02.73/7

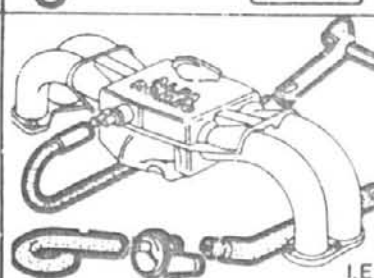

10

TAV

11

TAV 02.60/1

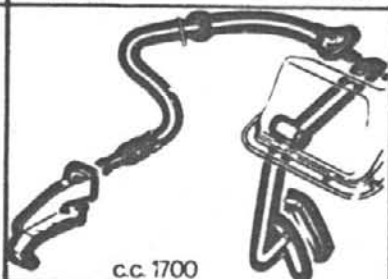

12

TAV 02.60/1

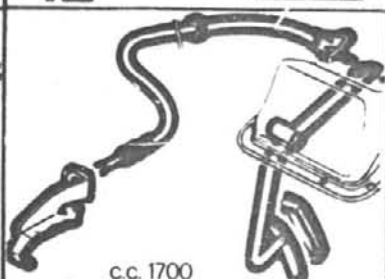

13

TAV 02.60

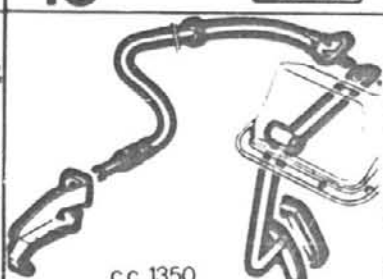

14

TAV 02.60

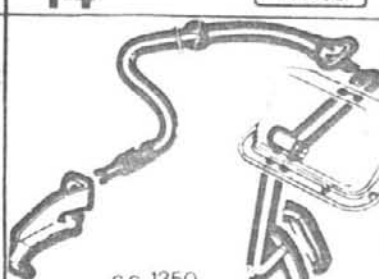

15

TAV 02.60/3

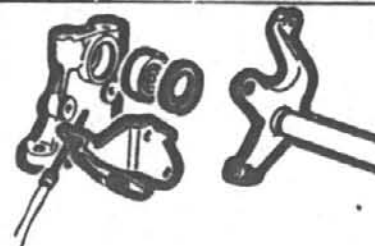

16

TAV 02.30/5



17

TAV 02.64



18

TAV



19

TAV



G₁

SPRINT
Ed. 87
Meccanica

1-1989

TAV. 02.70

c.c. 32

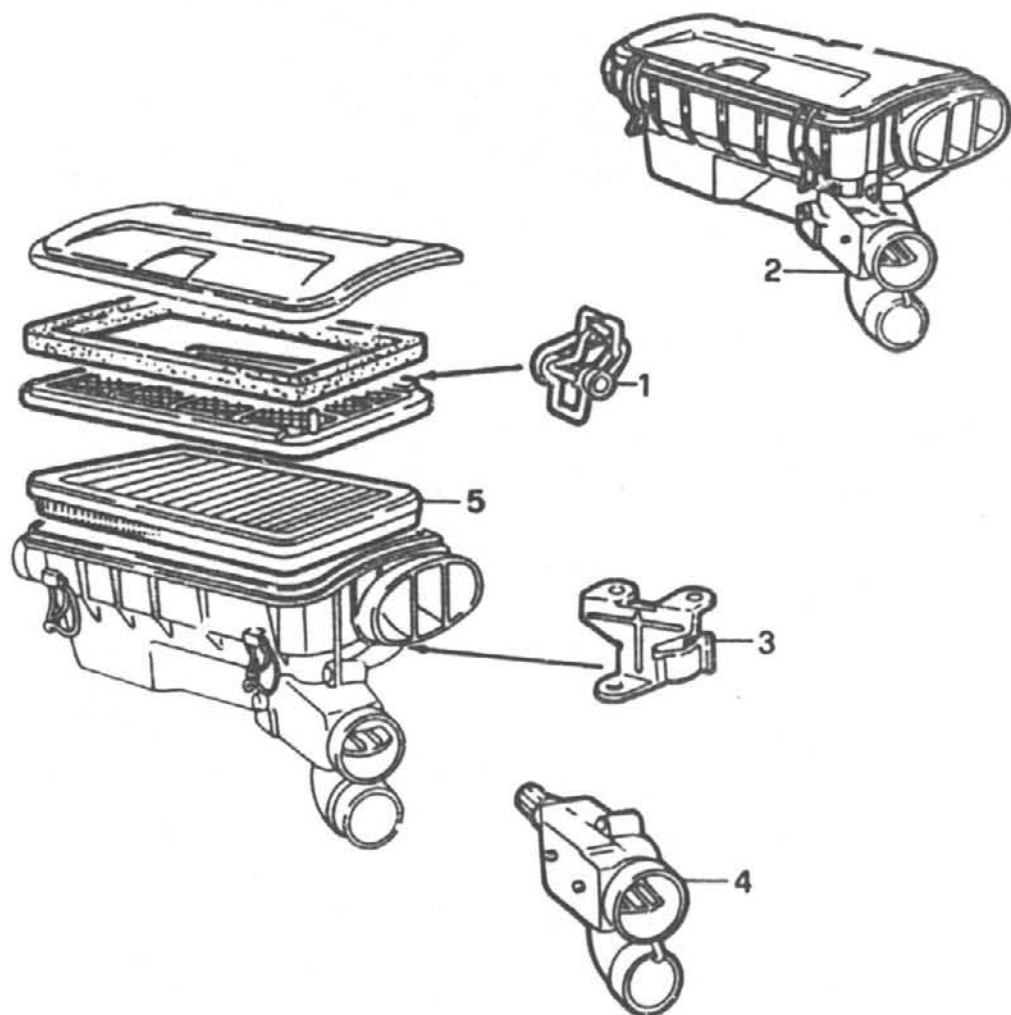

| pos. | TEILNUMMER | ref. | mg. benennung |
|------|-------------|------|------------------|
| 1 | 00607 38511 | | 4 KARABINERHAKEN |
| 2 | 00605 37477 | | 1 LUFTFILTER |
| 3 | 00607 49796 | | 1 HALTER |
| 4 | 00607 50414 | | 1 MISCHROHR |
| 5 | 00605 38923 | | 1 EINSATZ |

G₂

SPRINT
Ed. 87
Meccanica
1-1989

c.c. 1.7

TAV. 02.70/2

c.c. 32

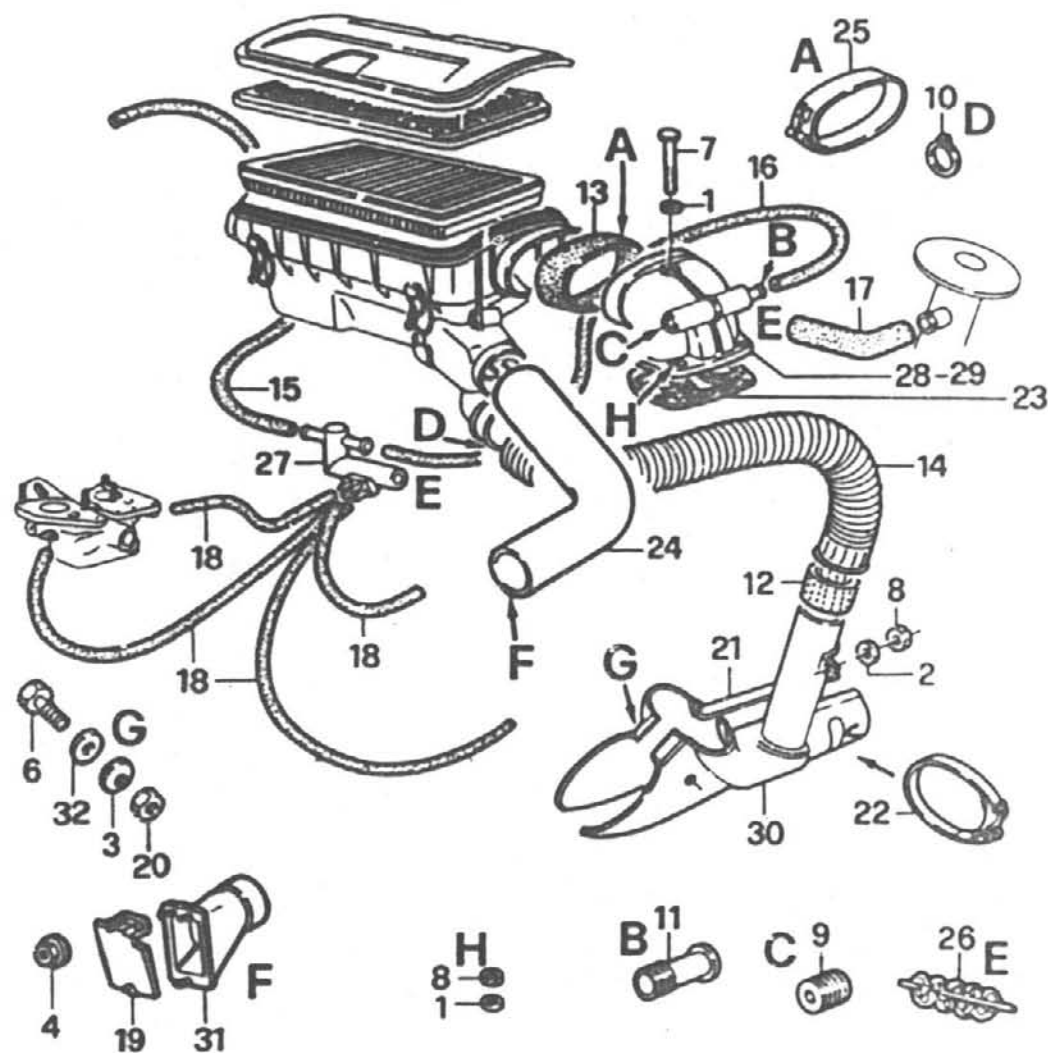

| pos. | TEILNUMMER | ref. | mg. benennung |
|------|-------------------|------|-------------------|
| 1 | 02100 31408 00 00 | | 6 SCHEIBE |
| 2 | 00111 94379 | | 6 SCHEIBE |
| 3 | 02100 81434 00 00 | | 6 SCHEIBE |
| 4 | 00140 84011 | | 3 MUTTER |
| 5 | 00109 78111 | | 1 SCHRAUBE |
| 6 | 02105 02017 00 00 | | 6 SCHRAUBE |
| 7 | 00110 30921 | | 2 SCHRAUBE |
| 8 | 00158 96211 | | 5 MUTTER |
| 9 | 00102 69650 | | 2 STOPFEN |
| 10 | 00605 02987 | | 1 SCHELLE |
| 11 | 00605 03019 | | 2 VERTEILER |
| 12 | 00605 03119 | | 1 BUECHSE |
| 13 | 00605 04860 | | 2 VERBINDUNGSRÖHR |
| 14 | 00605 17682 | | 1 VERBINDUNGSRÖHR |
| 15 | 00605 04870 | ↗ | 1 ROHR |
| 16 | 00605 04869 | ↖ | 1 ROHR |
| 17 | 00605 04866 | | 1 ROHR |
| 18 | 00605 17690 | | 4 ROEHRCHEN |
| 19 | 00605 17707 | | 1 TRENNWAND |
| 20 | 00161 00811 | | 1 MUTTER |
| 21 | 00605 24516 | | 1 LUFTEINLASS |
| 22 | 00605 24526 | | 1 SCHELLE |
| 23 | 00605 04856 | | 2 DICHTUNG |
| 24 | 00605 24895 | | 1 LUFTEINLASS |
| 25 | 00605 04861 | | 2 SCHELLE |

↗ Rechts
↖ Links



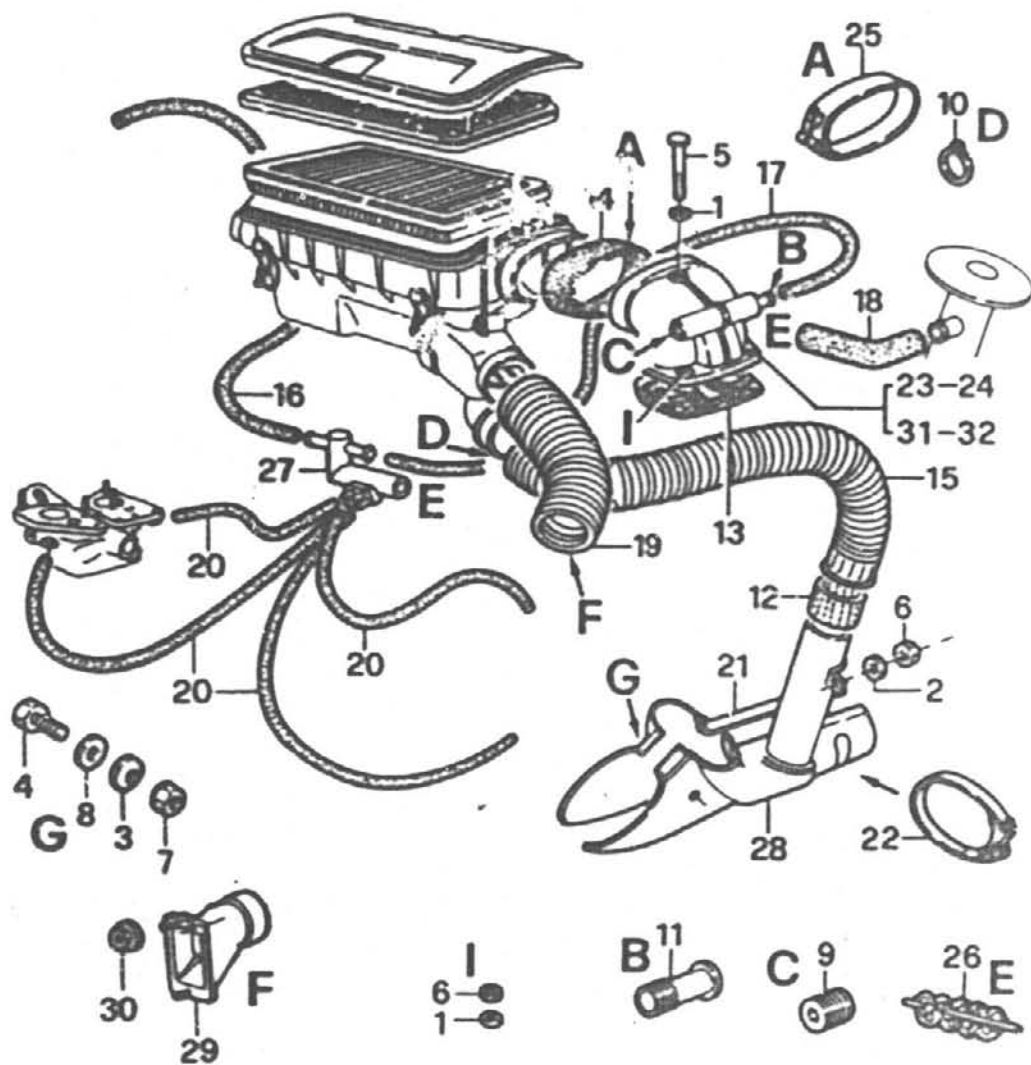

| pos. | TEILNUMMER | ref. | mg. benennung |
|------|-------------------|------|------------------|
| 1 | 02100 81408 00 00 | | 6 SCHEIBE |
| 2 | 00111 94379 | | 6 SCHEIBE |
| 3 | 02100 81434 00 00 | | 6 SCHEIBE |
| 4 | 00160 44621 | | 1 SCHRAUBE |
| 5 | 00110 30921 | | 2 SCHRAUBE |
| 6 | 00158 96211 | | 5 MUTTER |
| 7 | 00161 00811 | | 1 MUTTER |
| 8 | 00107 32211 | | 1 SCHEIBE |
| 9 | 00102 69650 | | 2 STOPFEN |
| 10 | 00605 02987 | | 1 SCHELLE |
| 11 | 00605 03019 | | 2 VERTEILER |
| 12 | 00605 03119 | | 1 BUECHSE |
| 13 | 00605 17617 | | 2 DICHTUNG |
| 14 | 00605 04860 | | 2 ANSCHLUSSTUECK |
| 15 | 00605 17682 | | 1 SCHUTZSCHLAUCH |
| 16 | 00605 04870 | ◆ | 1 ROHR |
| 17 | 00605 04869 | ◆ | 1 ROHR |
| 18 | 00605 04866 | | 1 ROHR |
| 19 | 00605 04862 | | 1 LUFTEINLASS |
| 20 | 00605 17690 | | 4 ROEHRCHEN |
| 21 | 00605 23722 | | 1 LUFTEINLASS |
| 22 | 00605 06562 | | 1 SCHELLE |
| 23 | 00605 36227 | ◆ | 1 KRUEMMER |
| 24 | 00605 36228 | ◆ | 1 KRUEMMER |
| 25 | 00605 04861 | | 2 SCHELLE |

◆ Rechts
◆ Links



G5

SPRINT
Ed. 87
Meccanica

1-1989

c.c. 1.3

TAV. 02.70/1

c.c. 32

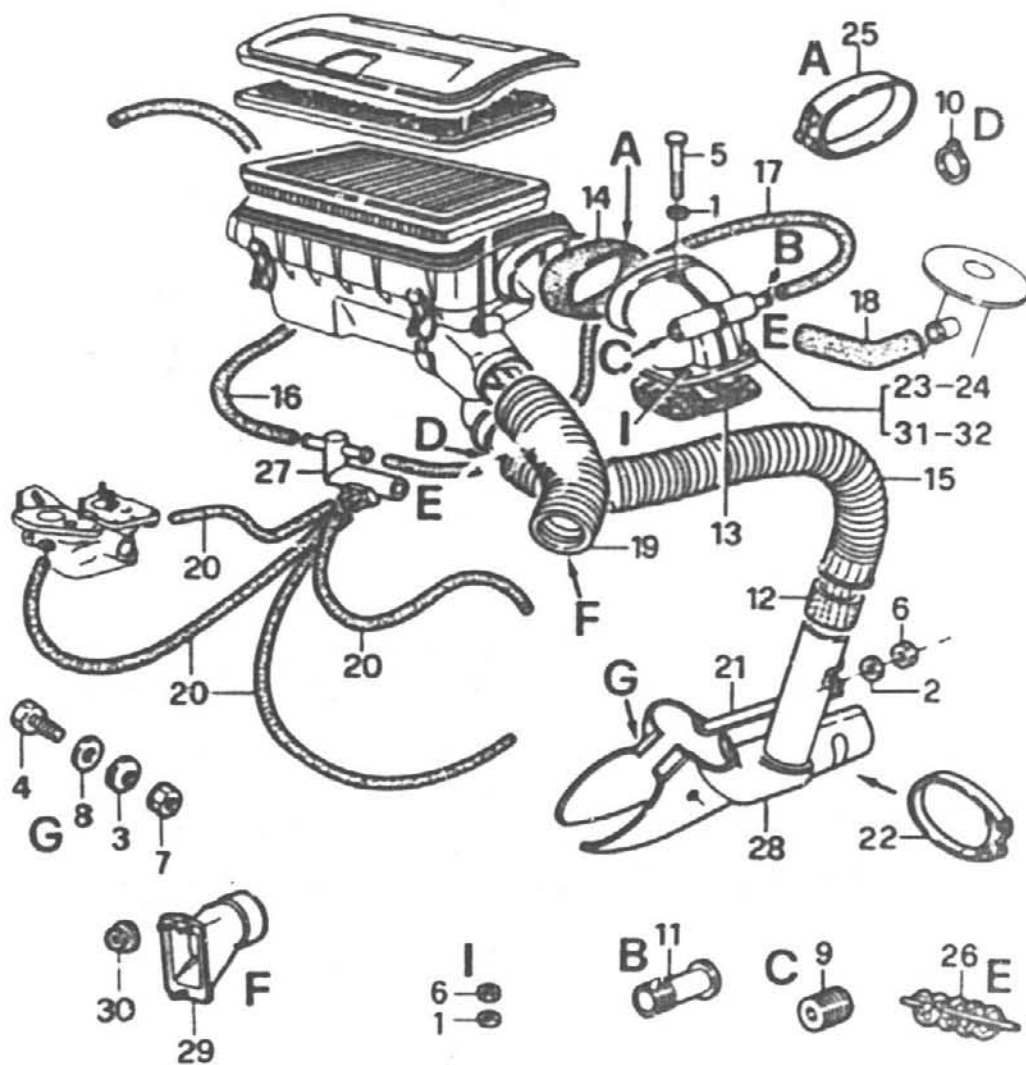

| pos. | TEILNUMMER | ref. | mg. | benennung | |
|------|-------------|------|-----|---------------|--|
| 26 | 00605 04868 | | 2 | FEUERLOESCHER | |
| 27 | 00605 04867 | | 2 | VERTEILER | |
| 28 | 00605 04305 | | 1 | LUFTEINLASS | |
| 29 | 00605 38120 | | 1 | HALTER | |
| 30 | 00140 39611 | | 1 | MUTTER | |
| 31 | 00605 04852 | ◆ ■ | 1 | KRUEMMER | |
| 32 | 00605 04855 | ◆ ■ | 1 | KRUEMMER | |

- ◆ Rechts
- 95 F.O.N.
- ◆ Links

G6

SPRINT
Ed. 87
Meccanica

1-1989

I.E.

TAV. 02.35

c.c. 32

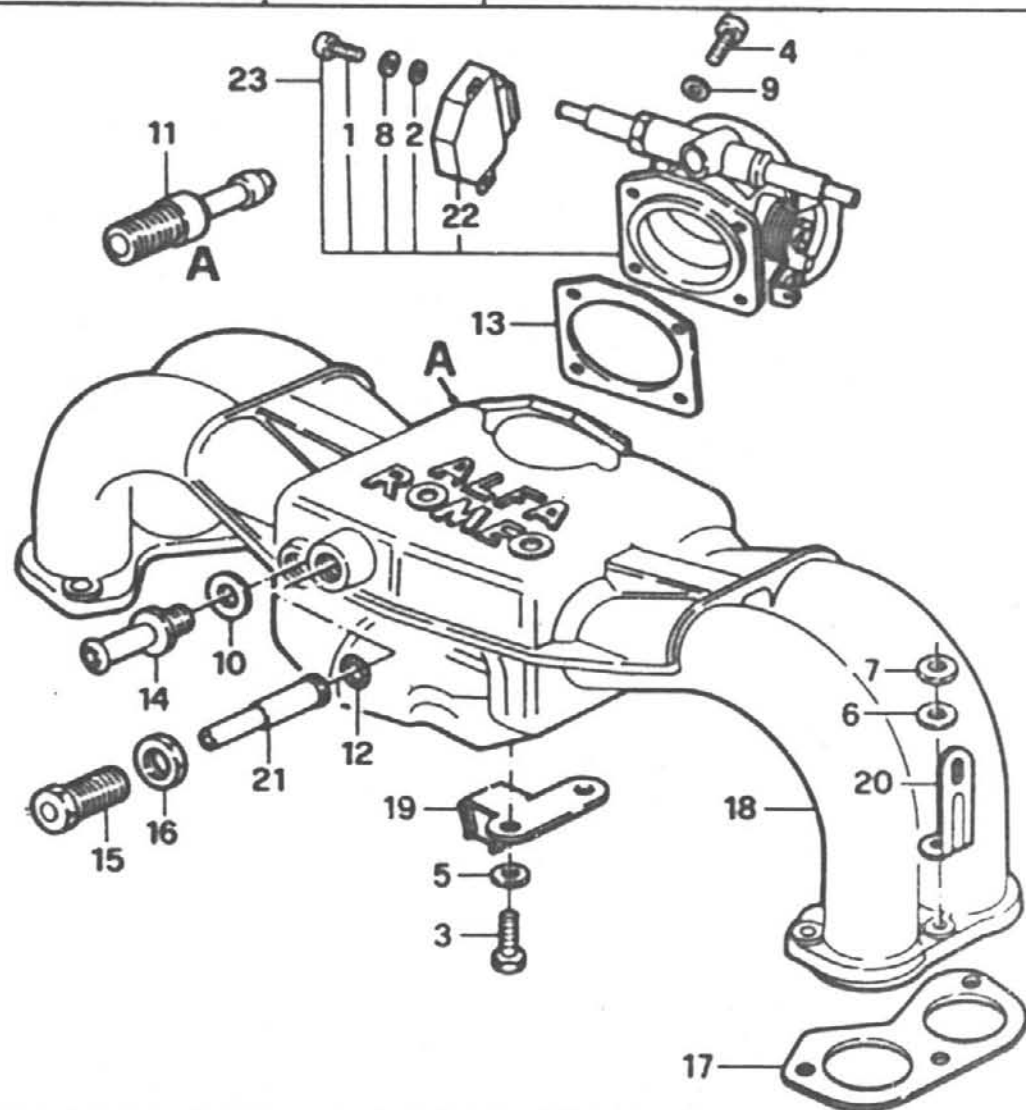

| pos. | TEILNUMMER | ref. | mg. benennung |
|------|-------------------|------|---------------|
| 1 | 00104 44513 | 2 | SCHRAUBE |
| 2 | 02100 81400 00 00 | 2 | SCHIEBE |
| 3 | 00109 79411 | 2 | SCHRAUBE |
| 4 | 00144 17821 | 1 | SCHRAUBE |
| 5 | 02105 81408 00 00 | 1 | SCHIEBE |
| 6 | 02105 81434 00 00 | 6 | SCHIEBE |
| 7 | 00161 00811 | 6 | MUTTER |
| 8 | 00135 06611 | 2 | SCHIEBE |
| 9 | 00126 03879 | 1 | SCHIEBE |
| 10 | 00102 80060 | 1 | DICHTUNG |
| 11 | 00605 06897 | 2 | VERTEILER |
| 12 | 00605 17044 | 1 | RING |
| 13 | 00605 18683 | 1 | DICHTUNG |
| 14 | 00605 18686 | 1 | VERTEILER |
| 15 | 00605 18738 | 1 | SCHRAUBE |
| 16 | 00605 18739 | 1 | MUTTER |
| 17 | 00605 24717 | 2 | DICHTUNG |
| 18 | 00605 24917 | 1 | GEHAEUSE |
| 19 | 00605 25089 | 1 | WINKELSTUECK |
| 20 | 00605 25143 | 2 | WINKELSTUECK |
| 21 | 00605 25640 | 1 | ROEHRCHEN |
| 22 | 00605 12672 | 1 | SCHALTER |
| 23 | 00605 38413 | 1 | GEHAEUSE |

G7

SPRINT
Ed. 87
Meccanica
1-1989

I.E.

TAV. 02.33

c.c. 32

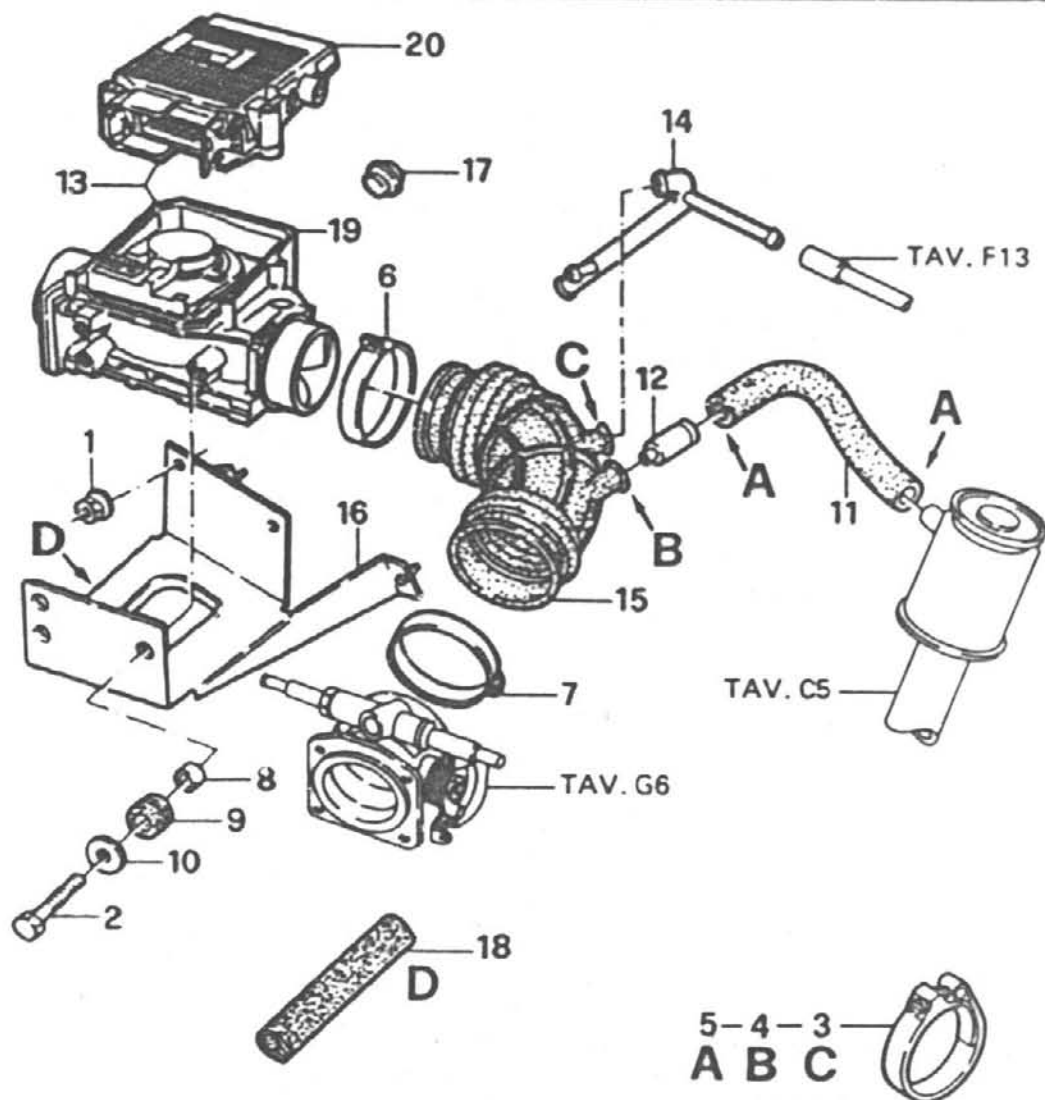

| pos. | TEILNUMMER | ref. | mg. benennung |
|------|-------------|------|--------------------|
| 1 | 00140 84211 | | 4 MUTTER |
| 2 | 00160 43611 | | 3 SCHRAUBE |
| 3 | 00131 00790 | | 1 SCHELLE |
| 4 | 00131 01190 | | 1 SCHELLE |
| 5 | 00607 07717 | | 2 SCHELLE |
| 6 | 00131 02890 | | 1 SCHELLE |
| 7 | 00131 03090 | | 1 SCHELLE |
| 8 | 00605 25070 | | 3 ABSTANDSTUECK |
| 9 | 00605 25071 | | 3 ZWISCHENSTUECK |
| 10 | 00605 25074 | | 6 SCHEIBE |
| 11 | 00605 25139 | | 1 ROHR |
| 12 | 00605 13187 | | 1 VERTEILER |
| 13 | 00605 37530 | | 1 WARNANZEIGE |
| 14 | 00605 38403 | | 1 VERTEILER |
| 15 | 00605 38402 | | 1 SCHALTMUFFE |
| 16 | 00605 38511 | | 1 WINKELSTUECK |
| 17 | 00605 23389 | | 1 STOPFEN |
| 18 | 00607 00750 | | 1 SNAPPON-DICHTUNG |
| 19 | 00607 55045 | | 1 WARNANZEIGE |
| 20 | 00607 55046 | | 1 ZJENDANLAGE |

G8

SPRINT
Ed. 87
Meccanica
1-1989

I.E.

TAV. 02.70/5

c.c. 32

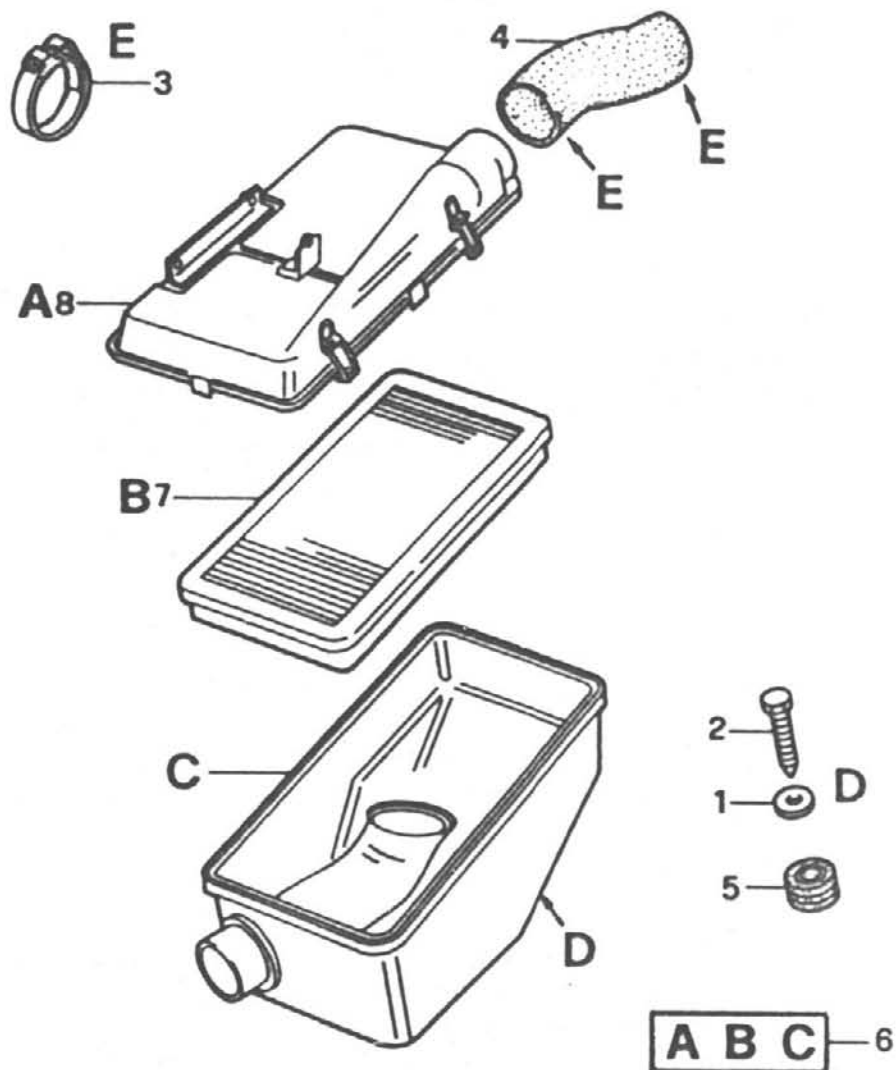

| pos. | TEILNUMMER | ref. | mg. benennung |
|------|-------------------|------|---------------|
| 1 | 02100 81414 00 00 | 2 | SCHEIBE |
| 2 | 00160 43211 | 2 | SCHRAUBE |
| 3 | 00131 02990 | 1 | SHELLE |
| 4 | 00605 25464 | 1 | SCHALTMUFFE |
| 5 | 00605 25465 | 2 | PUFFER |
| 6 | 00605 38404 | 1 | LUFTFILTER |
| 7 | 00605 38923 | 1 | EINSATZ |
| 8 | 00605 38400 | 1 | DECKEL |

G₉

SPRINT
Ed. 87
Meccanica

1-1989

I.E.

TAV. 02.73/7

c.c. 32

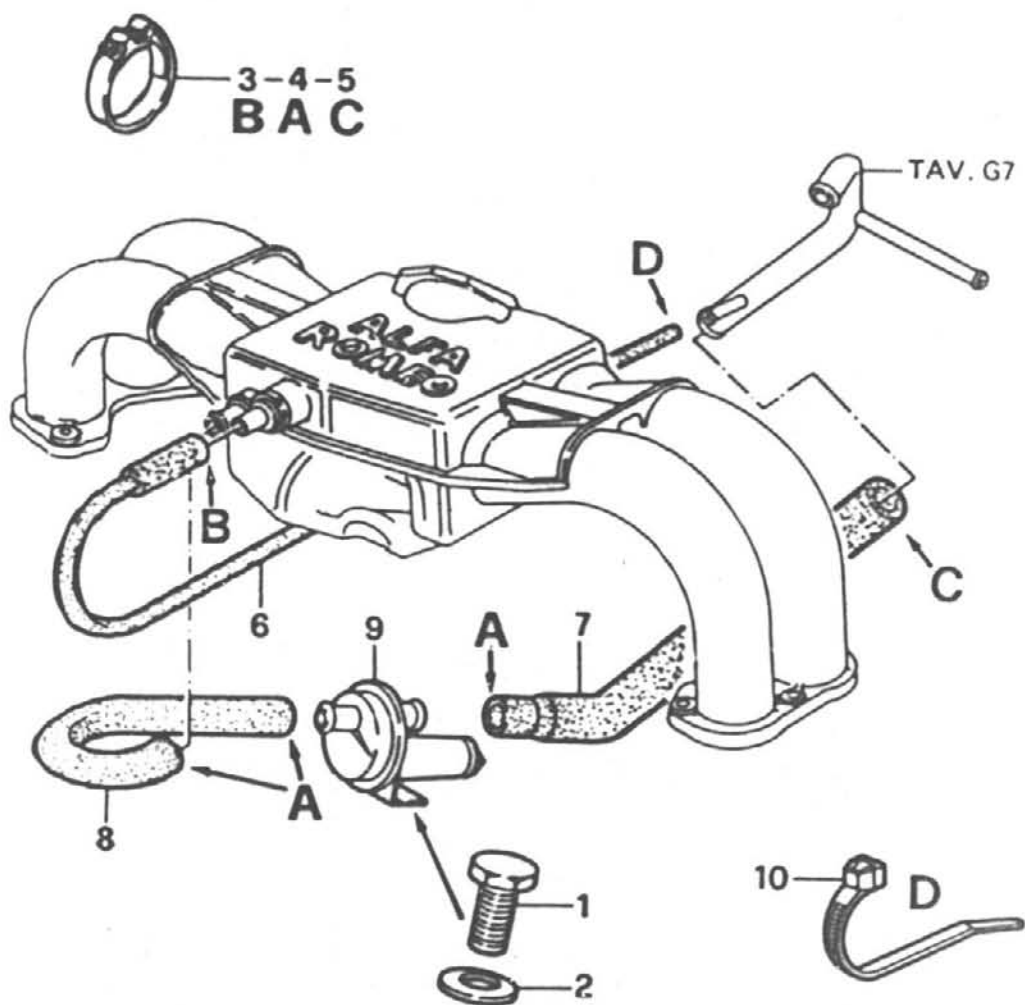

| pos. | TEILNUMMER | ref. | mg. | benennung |
|------|-------------------|------|-----|-----------|
| 1 | 00109 02121 | | 2 | SCHRAUBE |
| 2 | 02105 81408 00 00 | | 2 | SCHIEBE |
| 3 | 00131 00790 | | 1 | SCHELLE |
| 4 | 00131 00990 | | 3 | SCHELLE |
| 5 | 00607 07717 | | 1 | SCHELLE |
| 6 | 00605 24521 | | 1 | ROHR |
| 7 | 00605 25132 | | 1 | ROHR |
| 8 | 00605 25140 | | 1 | ROHR |
| 9 | 00605 37705 | | 1 | VENTIL |
| 10 | 12716 00000 00 00 | | 1 | SCHELLE |

G11

SPRINT
Ed. 87
Meccanica

1-1989

c.c. 1.7

TAV. 02.60/1

c.c. 32

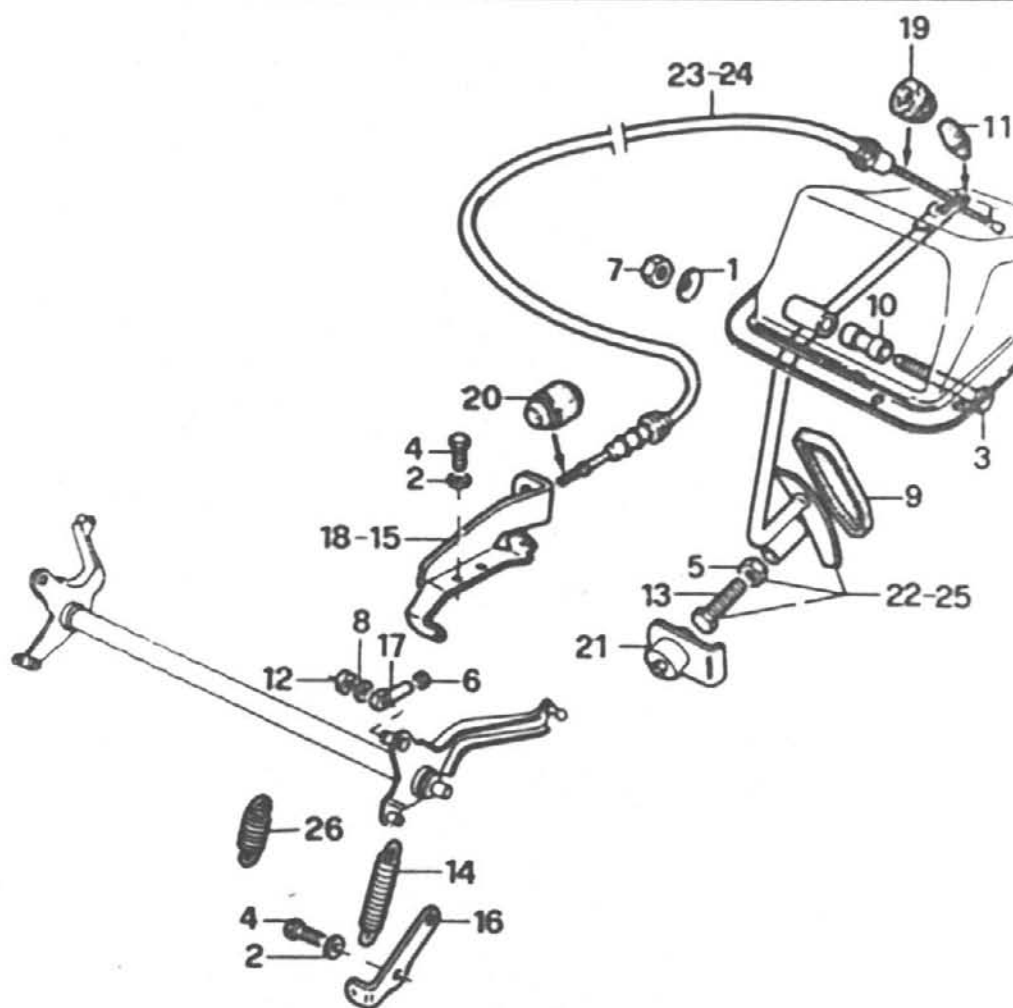

| pos. | TEILNUMMER | ref. | mq. | benennung |
|------|-------------------|------|-----|----------------|
| 1 | 00111 94379 | | 1 | SCHEIBE |
| 2 | 02100 81434 00 00 | | 18 | SCHEIBE |
| 3 | 00161 33221 | | 1 | SCHRAUBE |
| 4 | 00160 43221 | | 2 | SCHRAUBE |
| 5 | 00107 91013 | | 1 | MUTTER |
| 6 | 00158 96411 | | 1 | MUTTER |
| 7 | 00158 96211 | | 1 | MUTTER |
| 8 | 00135 79471 | | 1 | SCHEIBE |
| 9 | 00605 02966 | | 1 | PEDALGUMMI |
| 10 | 00605 03011 | | 1 | HUELSE |
| 11 | 00605 03013 | | 1 | GUMMITEIL |
| 12 | 00605 03017 | | 3 | SICHERUNGSRING |
| 13 | 00605 03092 | | 1 | SCHRAUBE |
| 14 | 00605 17611 | ⊙ | 1 | FEDER |
| 15 | 00605 17620 | ⊙ | 1 | PLATTE |
| 16 | 00605 17621 | ⊙ | 1 | HALTER |
| 17 | 00605 17642 | | 1 | GABEL |
| 18 | 00605 17725 | ⊠ | 1 | HALTER |
| 19 | 00605 25020 | | 1 | GUMMITEIL |
| 20 | 00605 25021 | | 1 | GUMMITEIL |
| 21 | 00605 36036 | | 1 | ANSCHLAG |
| 22 | 00605 37911 | ⊙ | 1 | FEDAL |
| 23 | 00605 37915 | ⊙ | 1 | ZUGKABEL |
| 24 | 00605 37916 | ⊠ | 1 | ZUGKABEL |
| 25 | 00605 37920 | ⊠ | 1 | GASPEDAL |

⊙ F. 2-1988

⊙ G.S.

⊠ G.D.



G12

SPRINT
Ed. 87
Meccanica
1-1989

c.c. 1.7

TAV. 02.60/1

c.c. 32

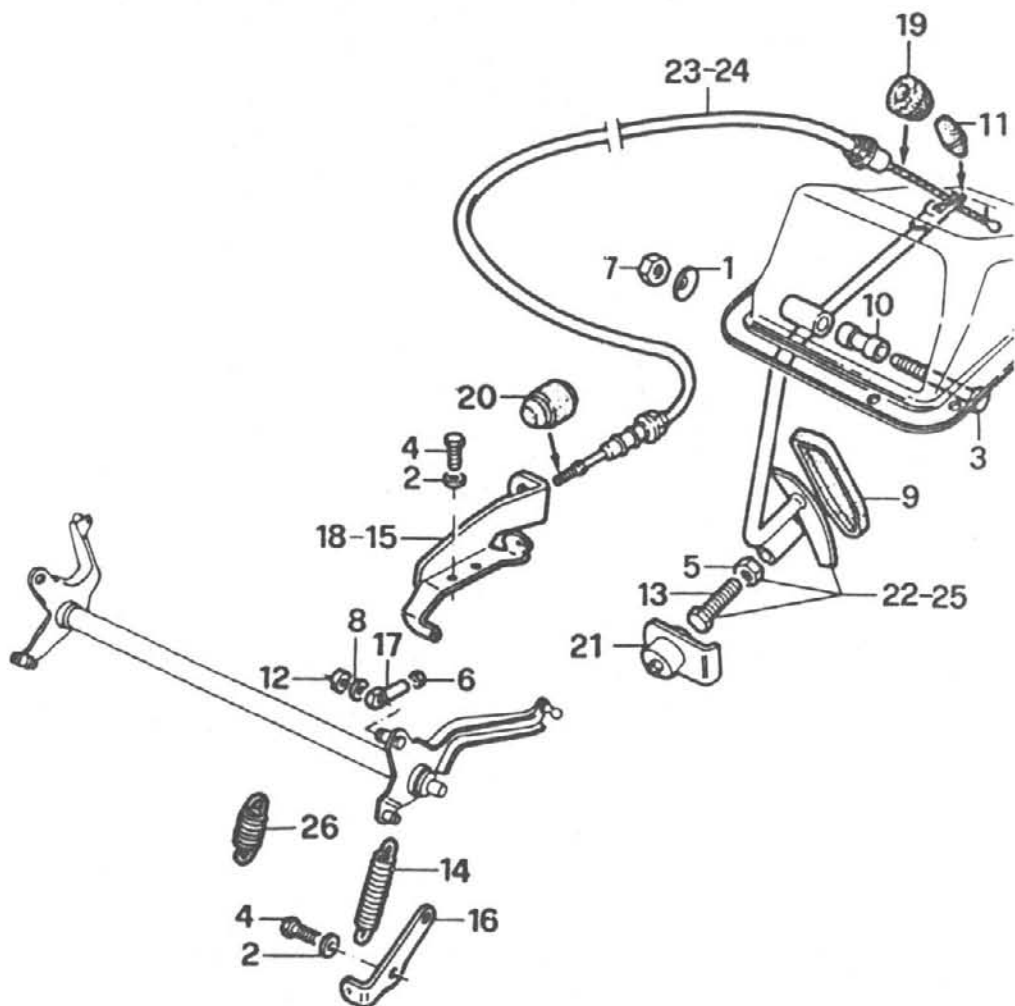

| pos. | TEILNUMMER | ref. | mg. | benennung | |
|------|-------------|------|-----|-----------|---|
| 26 | 00605 04811 | ⊙ | | 1 FEDER | ↑ |

G14

SPRINT
Ed. 87
Meccanica

1-1989

c.c. 1.3

TAV. 02.60

c.c. 32

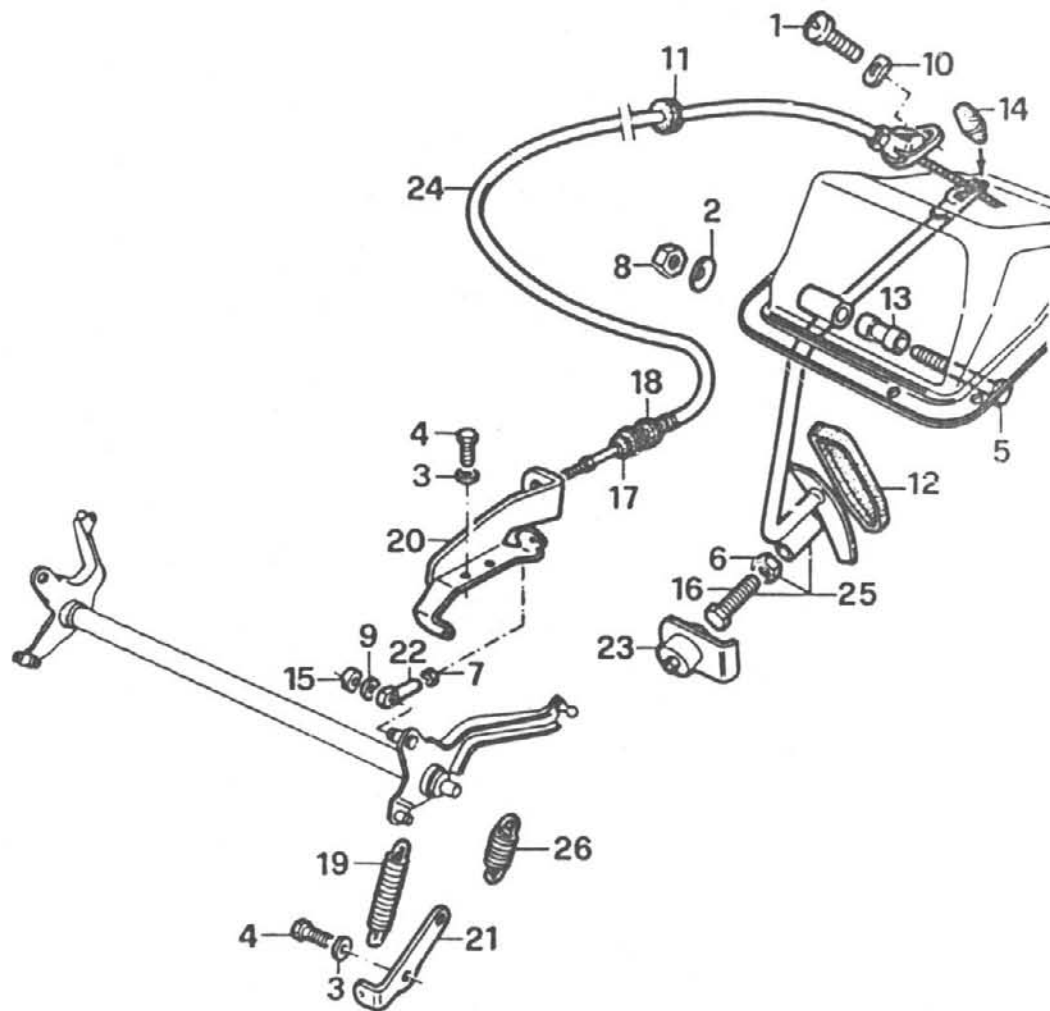

| pos. | TEILNUMMER | ref. | mg. | benennung | ↑ |
|------|-------------|------|-----|-----------|---|
| 26 | 00605 04811 | ⊙ | 1 | FEDER | |

G15

SPRINT
Ed. 87
Meccanica

1-1989

TAV. 02.60/3

c.c. 32

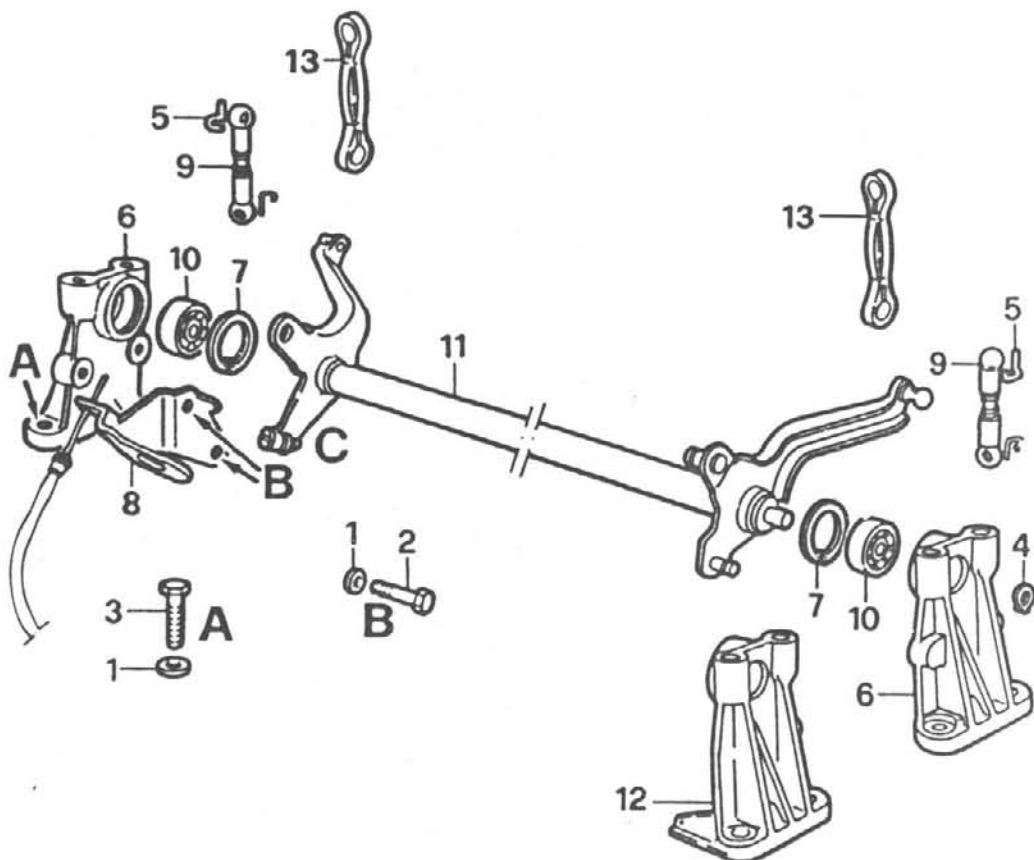

| pos. | TEILNUMMER | ref. | mg. benennung |
|------|------------------------|------|------------------|
| 1 | 02100 81434 00 00 | | 6 SCHEIBE |
| 2 | 00160 43221 | | 2 SCHRAUBE |
| 3 | 00160 43621 | | 4 SCHRAUBE |
| 4 | 00110 65770 | | 1 SICHERUNGSRING |
| 5 | 02300 00541 | | 4 BUEGEL |
| 6 | 00605 04798 | | 2 LAGERUNG |
| 7 | 00605 04802 | | 2 SPRENGRING |
| 8 | 00605 17696 | | 1 PLATTE |
| 9 | 00605 04813 | | 2 STANGE |
| 10 | 00605 04800 | | 2 LAGER |
| 11 | 00607 47262 | | 1 WELLE |
| 12 | 00605 04799 | ⊙ | 1 LAGERUNG |
| 13 | 00605 04812 | | 2 STANGE |

G17

SPRINT
Ed. 87
Meccanica

1-1989

TAV. 02.64

c.c. 32

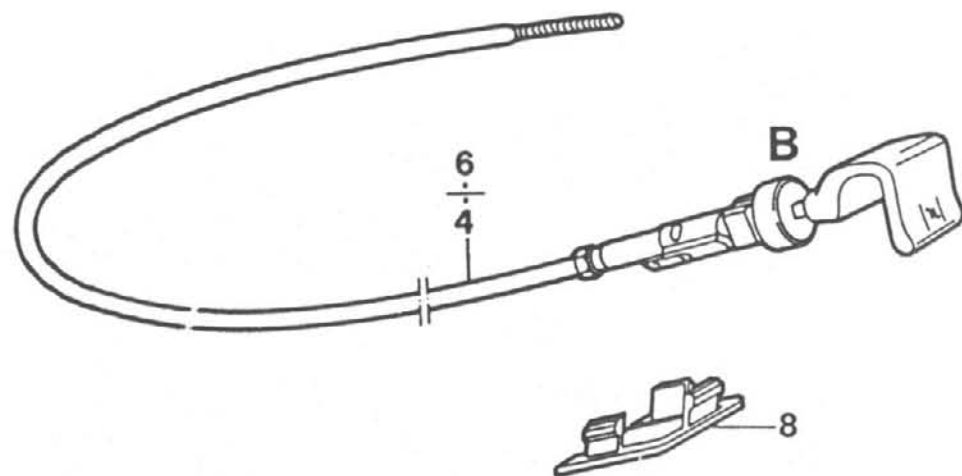
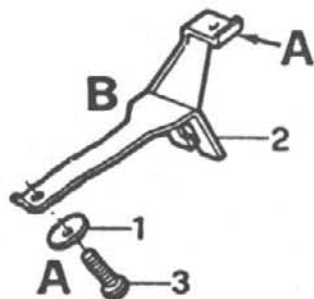

| pos. | TEILNUMMER | ref. | mg. benennung |
|------|-------------------|------|----------------------|
| 1 | 02100 81405 00 00 | | 2 SCHEIBE |
| 2 | 00605 03455 | | 1 HALTER |
| 3 | 00605 03518 | | 2 SCHRAUBE |
| 4 | 00605 36299 | ▲ | 1 CHOKE |
| 5 | 00605 36850 | ● □ | 1 CHOKE |
| 6 | 00605 06799 | ● ○ | 1 CHOKE |
| 7 | 00104 59787 | | 1 KABELDURCHFUEHRUNG |
| 8 | 00605 25488 | ■ | 1 STOPFEN |

▲ c.c. 1.3
● c.c. 1.7
■ G.D.

■ I.E.

H

1

TAV 02.40/3



WEBER c.c. 1700

2

TAV 02.48/1

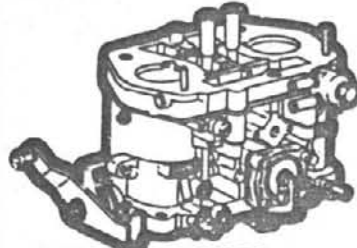

c.c. 1700 DELLORTO

3

TAV 02.40

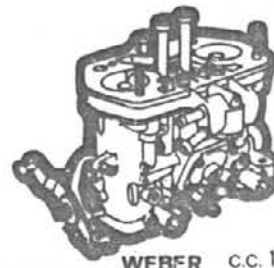

WEBER c.c. 1350

4

TAV 02.40

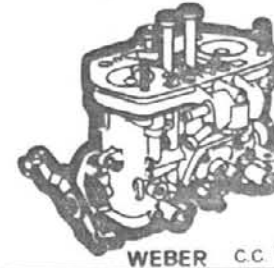

WEBER c.c. 1350

5

TAV 02.46



c.c. 1350 DELLORTO

6

TAV

7

TAV 02.35/5

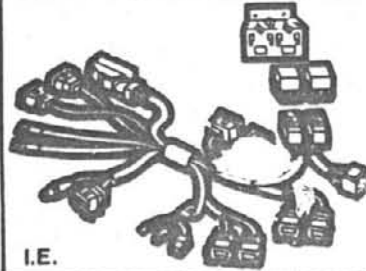

I.E.

8

TAV

9

TAV

10

TAV 41.00

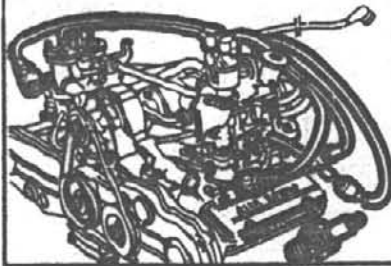

11

TAV 41.00/1

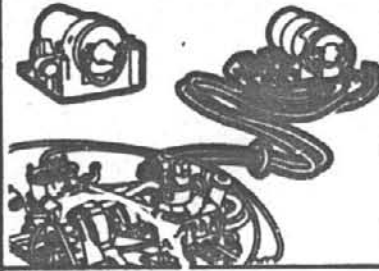

12

TAV 41.00/6

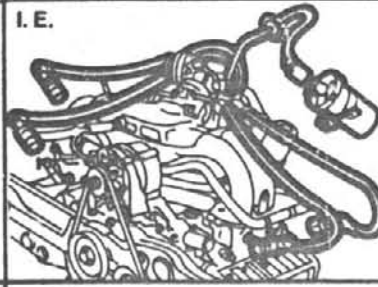

I.E.

13

TAV 41.21

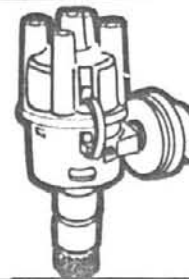

BOSCH

I.E.

14

TAV 41.27/3

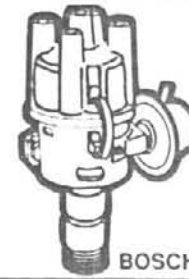

BOSCH - c.c. 1.7

15

TAV 41.21/1

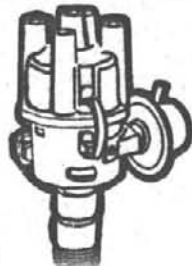

BOSCH

I.E.

16

TAV 41.28



MARELLI

17

TAV 41.25/1



DUCELLIER

18

TAV

19

TAV

H₁

SPRINT
Ed. 87
Meccanica

1-1989

c.c. 1.7 - WEBER

TAV. 02.40/3

c.c. 32

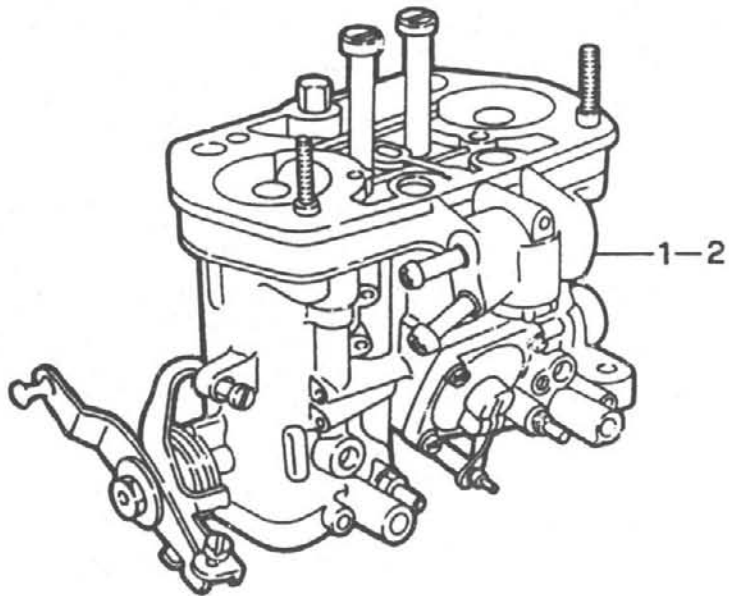

| pos. | TEILNUMMER | ref. | mg. benennung |
|------|-------------|------|---------------|
| 1 | 00605 15057 | ◆ | 1 VERGASER |
| 2 | 00605 37459 | ◆ | 1 VERGASER |

◆ Rechts
◆ Links

H₂

SPRINT
Ed. 87
Meccanica

1-1989

c.c. 1.7 - DELLORTO

TAV. 02.46/1

c.c. 32

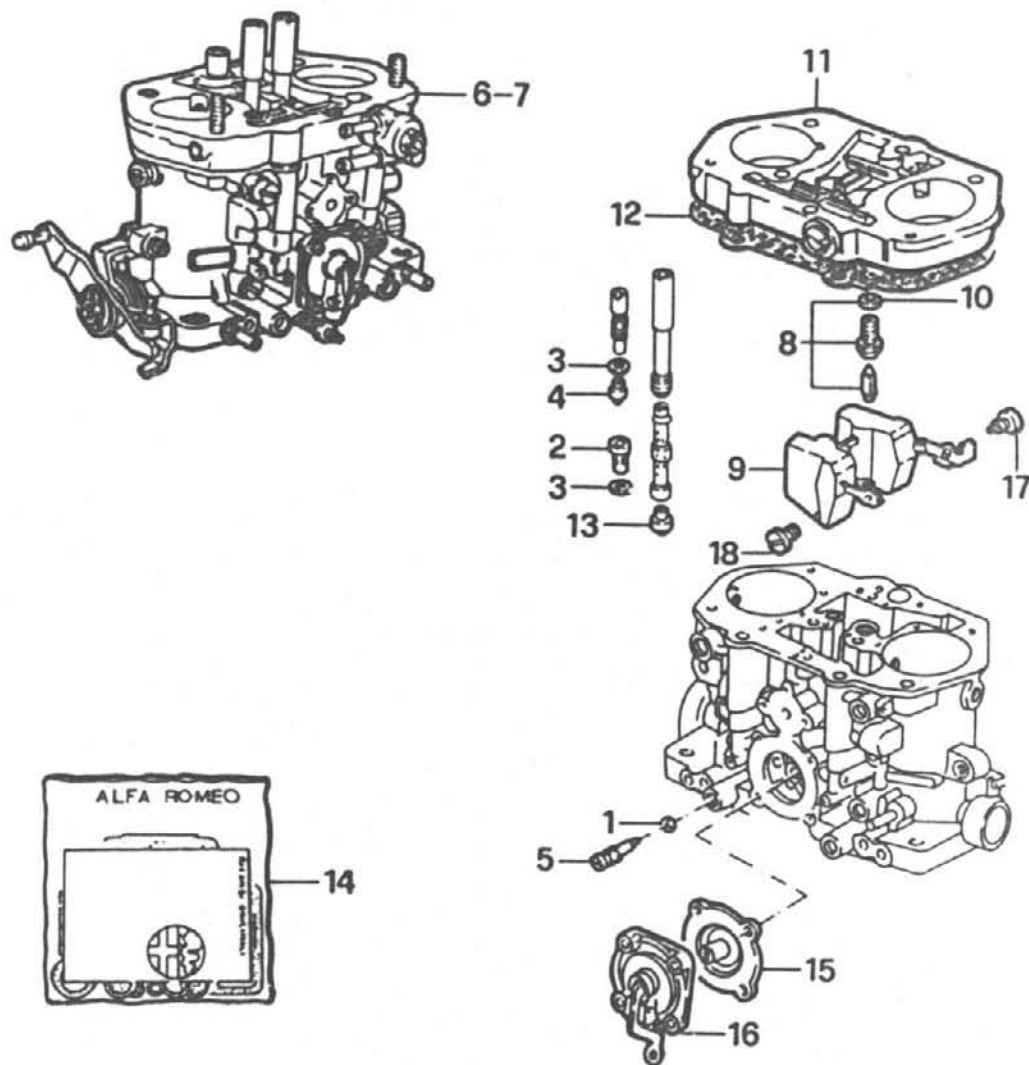

| pos. | TEILNUMMER | ref. | mg. benennung |
|------|-------------|------|-----------------|
| 1 | 00607 07730 | | 4 DICHTUNG |
| 2 | 00607 14203 | | 1 EINLASSVENTIL |
| 3 | 00607 14225 | | 3 DICHTUNG |
| 4 | 00607 27983 | | 2 LEERLAUFDUSE |
| 5 | 00607 29171 | | 2 SCHRAUBE |
| 6 | 00605 15059 | ◆ △ | 1 VERGASER |
| 7 | 00605 15060 | ◆ △ | 1 VERGASER |
| 8 | 00607 49716 | | 1 VENTIL |
| 9 | 00607 49718 | | 1 SCHWIMMER |
| 10 | 00607 49725 | | 1 DICHTUNG |
| 11 | 00607 50213 | | 1 DECKEL |
| 12 | 00607 50214 | | 1 DICHTUNG |
| 13 | 00607 50215 | | 2 HAUPTDUESE |
| 14 | 00607 50216 | | 1 DICHTUNGSSATZ |
| 15 | 00607 50217 | | 1 MEMBRANE |
| 16 | 00607 50218 | | 1 DECKEL |
| 17 | 00607 50219 | | 1 BOLZEN |
| 18 | 00607 50220 | | 1 BOLZEN |

- ◆ Rechts
- △ DRLA - 40 - F
- ◆ Links

H₃

SPRINT
Ed. 87
Meccanica

1-1989

c.c. 1.3 - WEBER

TAV. 02.40

c.c. 32

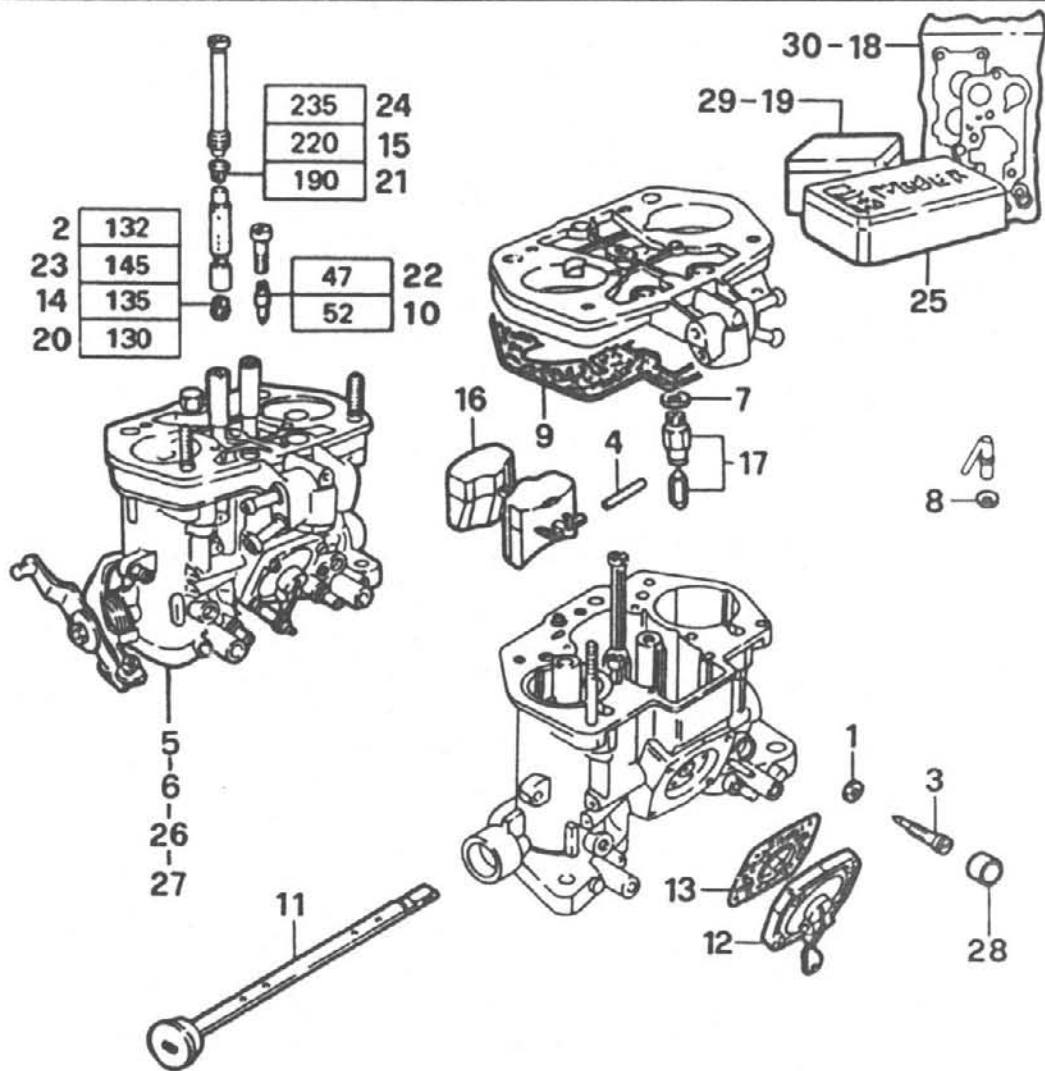

| pos. | TEILNUMMER | ref. | mg. benennung |
|------|-------------|------|--------------------|
| 1 | 00607 07733 | | 1 DICHRING |
| 2 | 00607 23727 | | 4 HAUPTDUESE |
| 3 | 00607 23735 | | 1 EINSTELLSCHRAUBE |
| 4 | 00607 24998 | | 2 BOLZEN |
| 5 | 00605 36242 | ↗ | 1 VERGASER |
| 6 | 00605 36243 | ↘ | 1 VERGASER |
| 7 | 00607 49090 | | 2 DICHTUNG |
| 8 | 00607 49162 | | 4 DICHRING |
| 9 | 00607 49630 | | 1 DICHTUNG |
| 10 | 00607 49633 | | 4 LEERLAUFDUSE |
| 11 | 00607 49643 | | 2 WELLE |
| 12 | 00607 49645 | | 1 PUMPE |
| 13 | 00607 49646 | | 1 MEMBRANE |
| 14 | 00607 49670 | | 4 HAUPTDUESE |
| 15 | 00607 49672 | | 4 LUFTDUSE |
| 16 | 00099 21377 | | 2 SCHWIMMER |
| 17 | 00607 49690 | | 2 NADELVENTIL |
| 18 | 00607 49695 | | 1 DICHTUNGSSATZ |
| 19 | 00607 49696 | | 1 REPARATURSATZ |
| 20 | 00607 49831 | | 4 HAUPTDUESE |
| 21 | 00607 50035 | | 4 LUFTDUSE |
| 22 | 00607 50038 | | 4 LEERLAUFDUSE |
| 23 | 00607 50039 | | 4 HAUPTDUESE |
| 24 | 00607 50067 | | 4 LUFTDUSE |
| 25 | 00607 50788 | | 1 REPARATURSATZ |

↗ Rechts
↘ Links



H4

SPRINT
Ed. 87
Meccanica

1-1989

c.c. 1.3 - WEBER

TAV. 02.40

c.c. 32

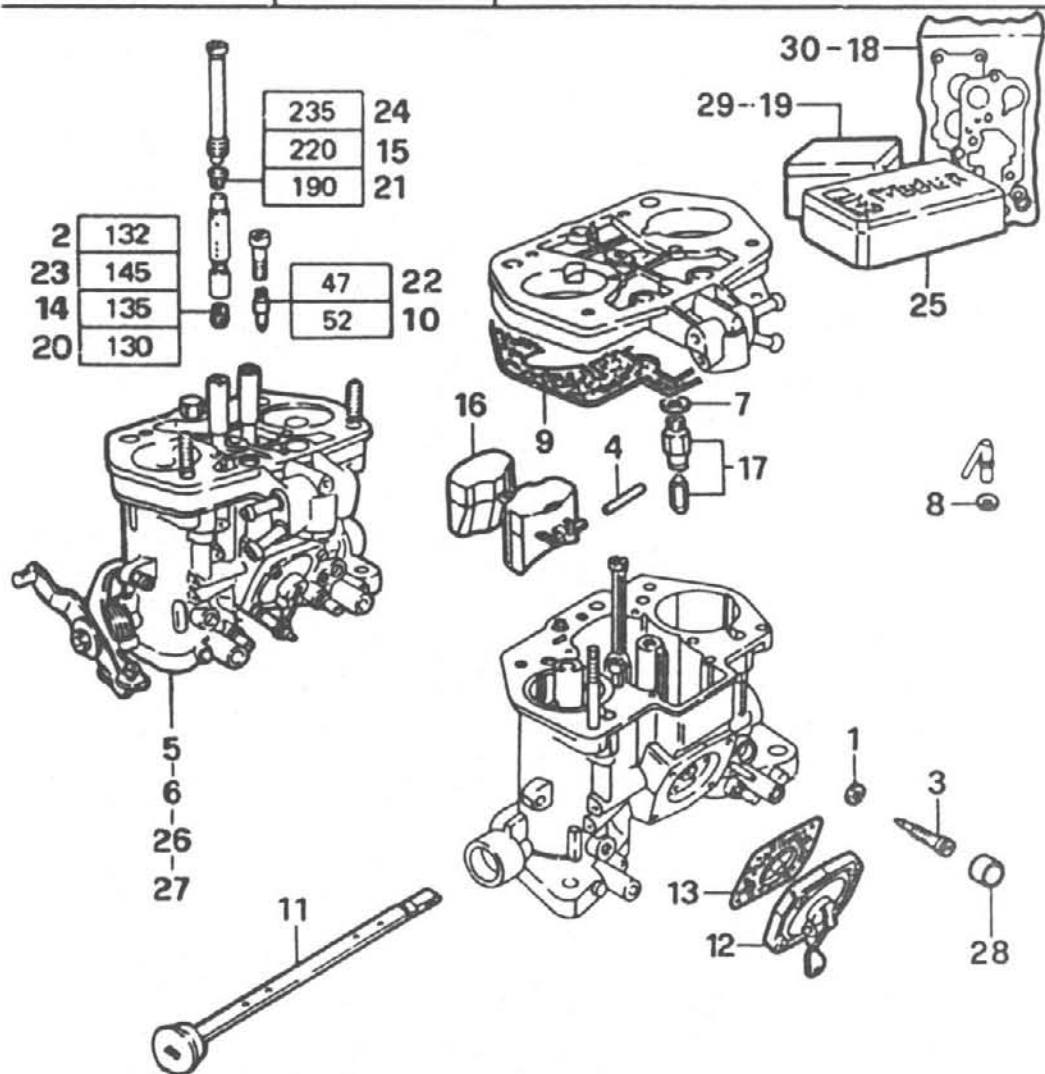

| pos. | TEILNUMMER | ref. | mg. | benennung | |
|------|-------------|------|-----|---------------|--|
| 26 | 00605 04790 | ◆ ■ | 1 | VERGASER | |
| 27 | 00605 04792 | ◆ ■ | 1 | VERGASER | |
| 28 | 00607 50268 | | 4 | STOPFEN | |
| 29 | 00607 50270 | ■ | 1 | REPARATURSATZ | |
| 30 | 00607 50271 | ■ | 1 | DICHTUNGSSATZ | |

◆ Rechts
■ 95 R.O.N.
◆ Links

H5

SPRINT
Ed. 87
Meccanica

1-1989

c.c. 1.3 - DELLORTO

TAV. 02.46

c.c. 32

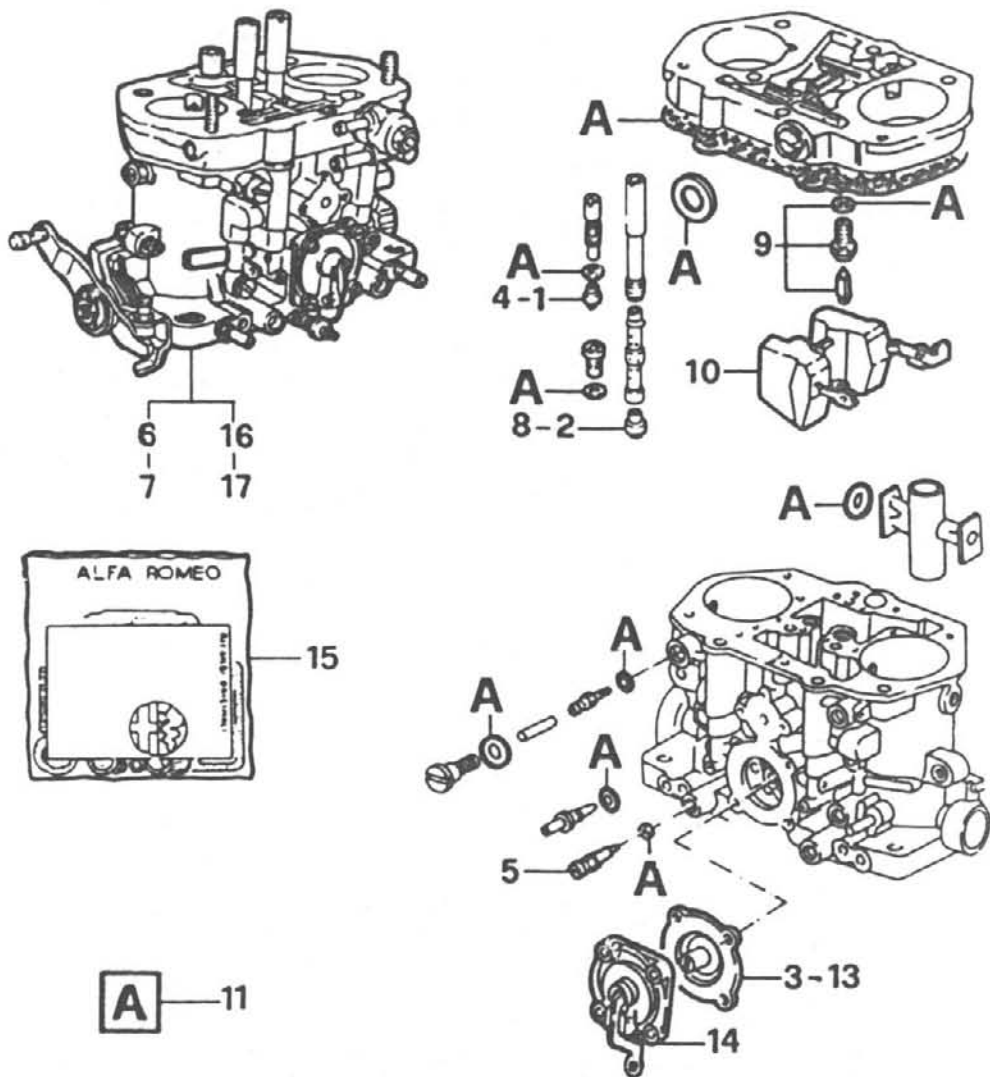

| pos. | TEILNUMMER | ref. | mg. | benennung |
|------|-------------|------|-----|---------------|
| 1 | 00607 55000 | ■ | 4 | SCHEIBE |
| 2 | 00607 55004 | ■ | 4 | HAUPTDUESE |
| 3 | 00607 55002 | ■ | 2 | MEMBRANE |
| 4 | 00607 27983 | | 4 | LEERLAUFDUSE |
| 5 | 00607 29171 | | 2 | SCHRAUBE |
| 6 | 00605 36300 | ◆ | 1 | VERGASER |
| 7 | 00605 36301 | ◆ | 1 | VERGASER |
| 8 | 00607 49713 | | 4 | HAUPTDUESE |
| 9 | 00607 49716 | | 2 | VENTIL |
| 10 | 00607 49718 | | 2 | SCHWIMMER |
| 11 | 00607 55003 | ■ | 1 | REPARATURSATZ |
| 13 | 00607 49752 | | 2 | MEMBRANE |
| 14 | 00607 49753 | | 2 | DECKEL |
| 15 | 00607 50033 | | 1 | REPARATURSATZ |
| 16 | 00605 04791 | ◆ ■ | 1 | VERGASER |
| 17 | 00605 04793 | ◆ ■ | 1 | VERGASER |

- 95 F.O.N.
- ◆ Rechts
- ◆ Links

H7

SPRINT
Ed. 87
Meccanica
1-1989

I.E.

TAV. 02.35/5

c.c. 32

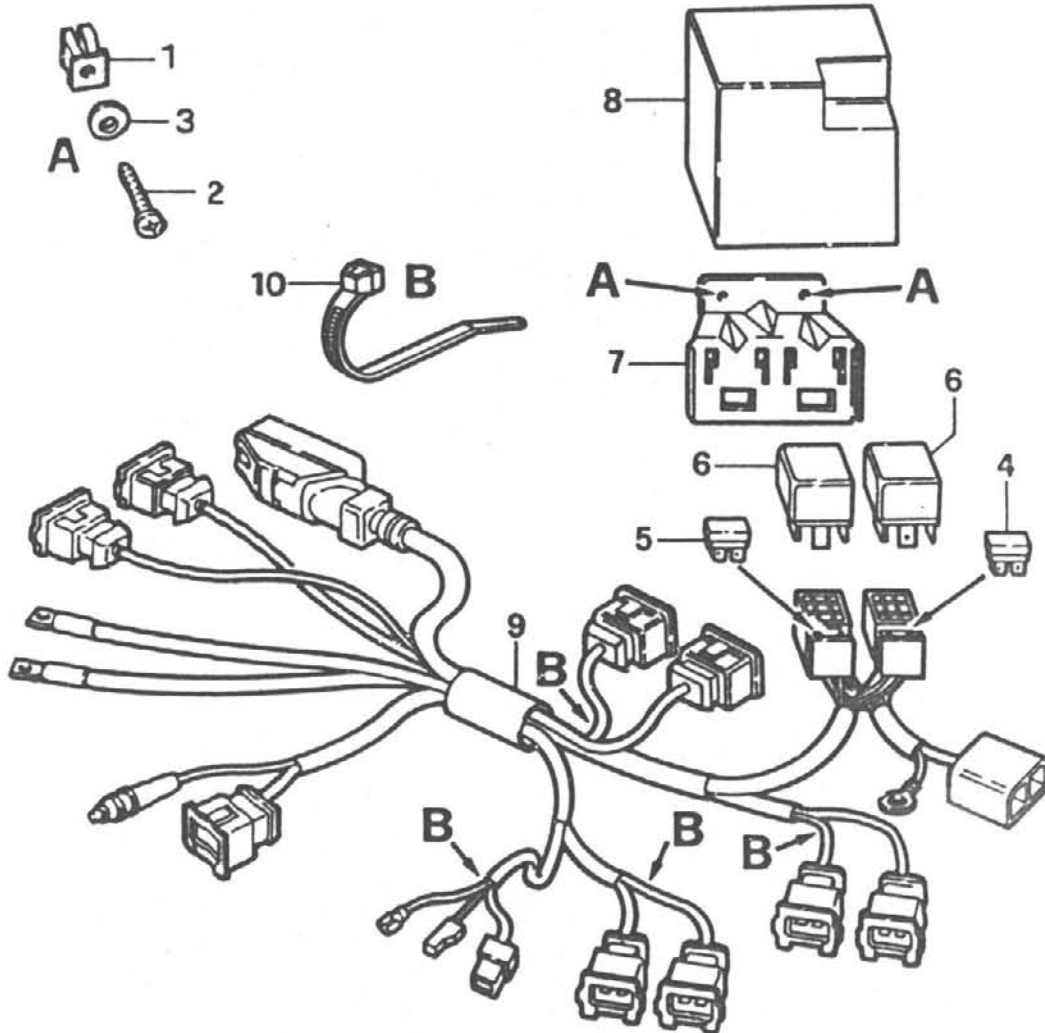

| pos. | TEILNUMMER | ref. | mg. benennung |
|------|-------------------|------|----------------|
| 1 | 00142 01980 | | 2 INNENGEWINDE |
| 2 | 02105 16339 00 00 | | 2 SCHRAUBE |
| 3 | 02105 81405 00 00 | | 2 SCHEIBE |
| 4 | 00110 54890 | | SICHERUNG |
| 5 | 00110 55090 | | SICHERUNG |
| 6 | 11610 65135 07 00 | | 1 RELAIS |
| 7 | 00605 06411 | | 1 BUEGEL |
| 8 | 00605 25234 | | 1 ABDECKUNG |
| 9 | 00605 38481 | | 1 KABELSATZ |
| 10 | 12716 00000 00 00 | | 4 SCHELLE |

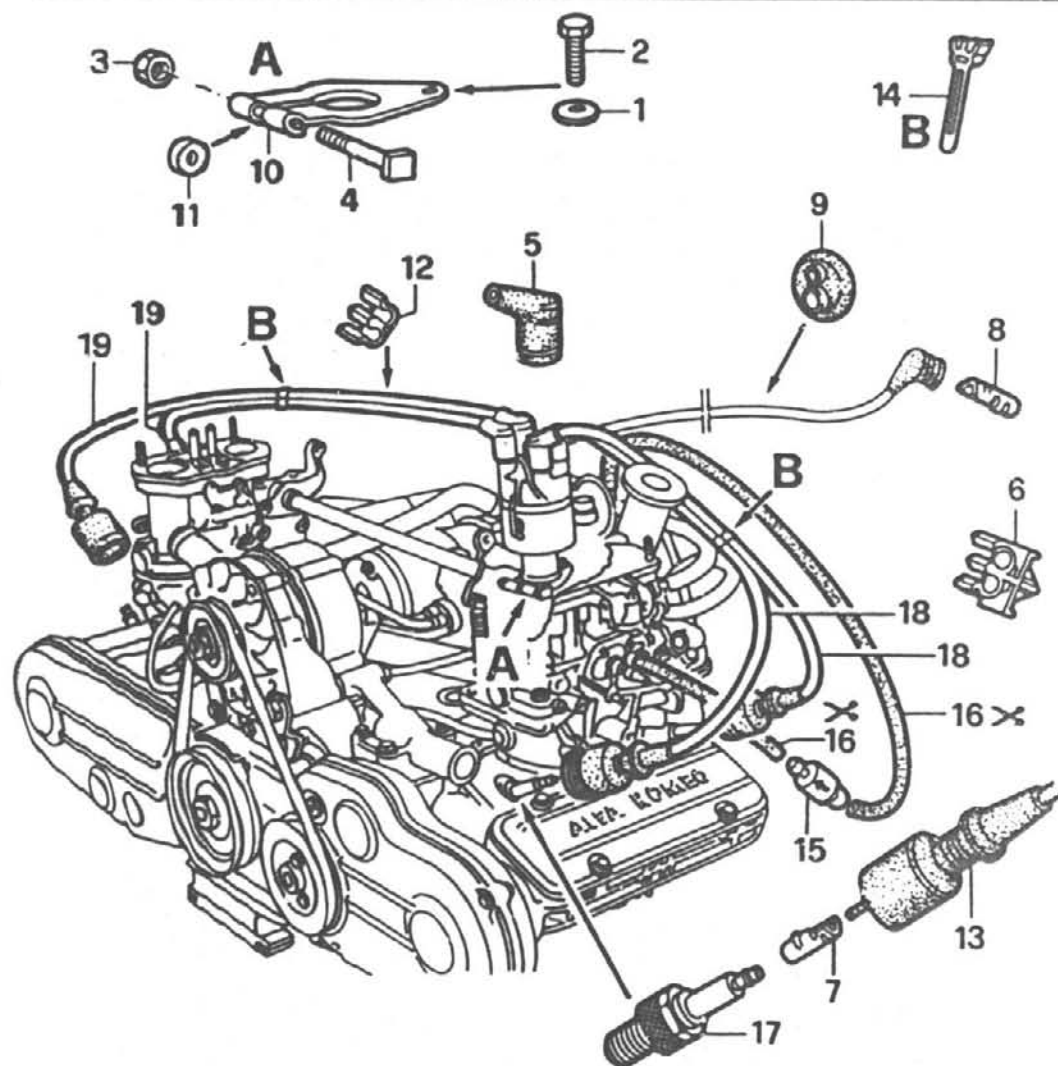

| pos. | TEILNUMMER | ref. | mg. benennung |
|------|-------------------|------|---------------|
| 1 | 00111 94379 | | 2 SCHEIBE |
| 2 | 00109 02221 | | 1 SCHRAUBE |
| 3 | 00158 96211 | | 1 MUTTER |
| 4 | 00605 02950 | | 1 SCHRAUBE |
| 5 | 10255 50000 00 00 | | 6 KAPPE |
| 6 | 00605 03005 | | 1 LAGERUNG |
| 7 | 00120 56340 | | 4 ENDSTUECK |
| 8 | 00120 56440 | | 6 ENDSTUECK |
| 9 | 00605 15697 | | 1 GUMMITEIL |
| 10 | 00605 03014 | | 1 HALTER |
| 11 | 00605 03015 | | 1 SCHEIBE |
| 12 | 10776 00000 00 00 | | 2 LAGERUNG |
| 13 | 00605 03156 | | 4 KAPPE |
| 14 | 00605 04825 | | 2 LAGERUNG |
| 15 | 00605 04821 | | 1 VENTIL |
| 16 | 00670 99951 | | ROHR |
| 17 | 00605 04563 | | 4 ZUENDKERZE |
| 18 | 00605 04232 | | 2 KABEL L 640 |
| 19 | 00605 04823 | | 2 KABEL L 730 |

H11

SPRINT
Ed. 87
Meccanica

1-1989

TAV. 41.00/1

c.c. 32

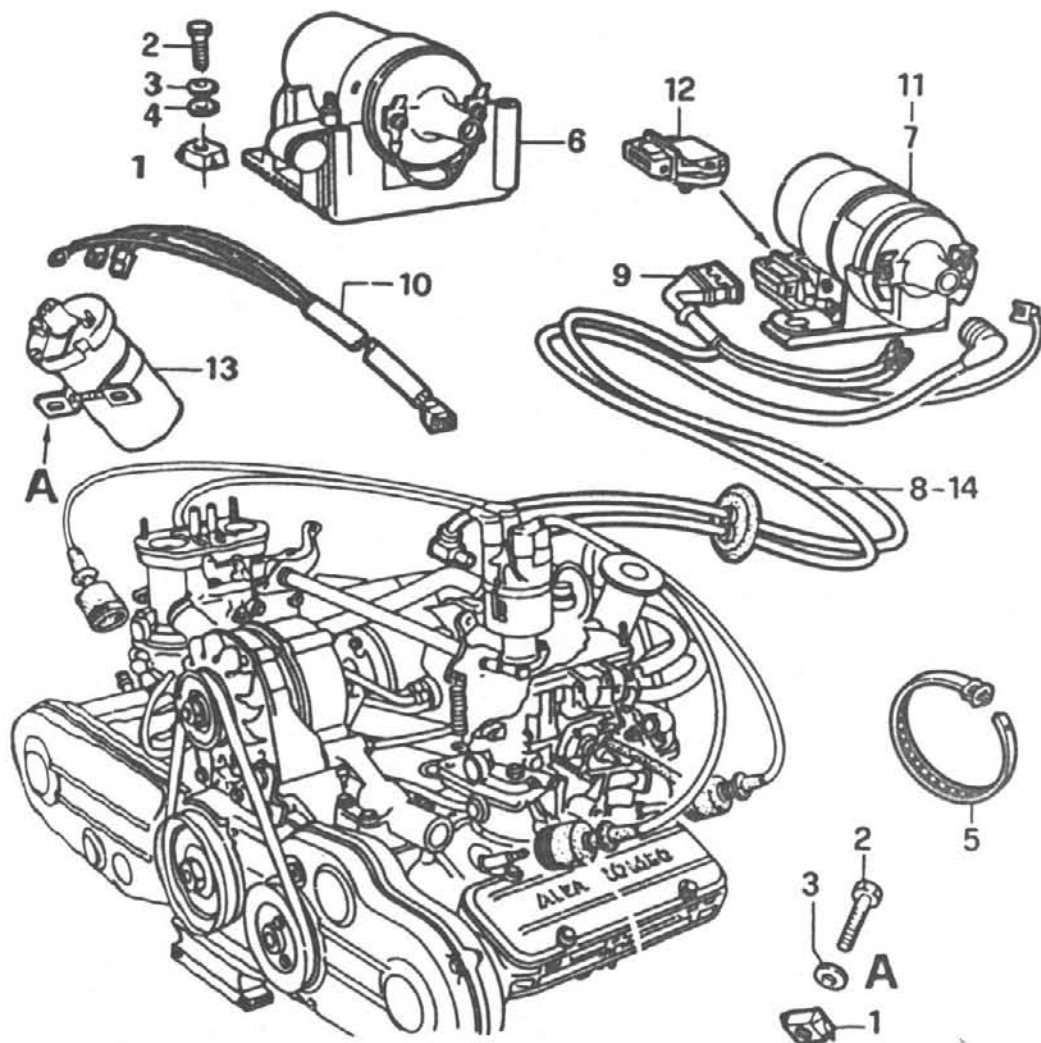

| pos. | TEILNUMMER | ref. | mg. benennung |
|------|-------------------|------|---------------|
| 1 | 00146 48390 | | 2 MUTTER |
| 2 | 00109 02411 | | 2 SCHRAUBE |
| 3 | 02105 81409 00 00 | | 2 SCHEIBE |
| 4 | 00135 77911 | | 2 SCHEIBE |
| 5 | 00605 01092 | | 1 SCHELLE |
| 6 | 00605 04289 | ■ | 1 ZUENDSPULE |
| 7 | 00605 04288 | ■ | 1 ZUENDSPULE |
| 8 | 00605 04325 | | 1 KABEL |
| 9 | 00605 04326 | | 1 KABELSATZ |
| 10 | 00605 43576 | □ ○ | 1 KABELSATZ |
| 11 | 00605 04337 | | 1 ZUENDSPULE |
| 12 | 00607 50065 | | 1 VORRICHTUNG |
| 13 | 00605 37610 | □ ○ | 1 ZUENDSPULE |
| 14 | 00605 36124 | ■ | 1 KABEL |

■ MARELLI

■ BOSCH

□ c.c. 1.3 D. T. 5135427

■ c.c. 1.395 R.O.N.

H12

SPRINT
Ed. 87
Meccanica

1-1989

I.E.

TAV. 41.00/6

c.c. 32

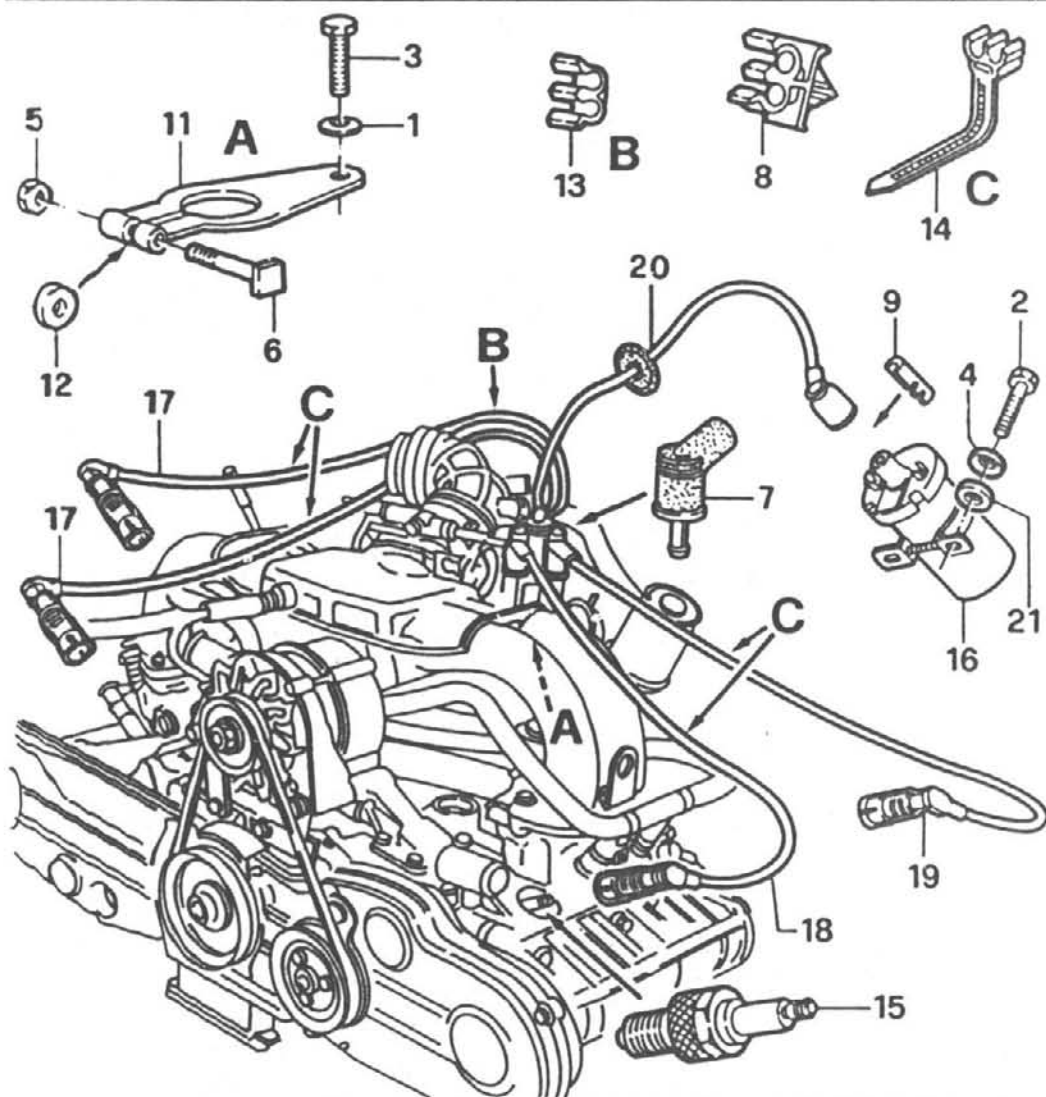

| pos. | TEILNUMMER | ref. | mg. benennung |
|------|-------------------|------|----------------|
| 1 | 00111 94379 | | 2 SCHEIBE |
| 2 | 00109 02111 | | 1 SCHRAUBE |
| 3 | 00109 02221 | | 1 SCHRAUBE |
| 4 | 02105 81409 00 00 | | 2 KLEMMSCHEIBE |
| 5 | 00158 96211 | | 1 MUTTER |
| 6 | 00605 02950 | | 1 SCHRAUBE |
| 7 | 10255 50000 00 00 | | 6 KAPPE |
| 8 | 00605 03005 | | 1 LAGERUNG |
| 9 | 00120 56440 | | 6 ENDSTUECK |
| 10 | 00605 15697 | | 1 GUMMITEIL |
| 11 | 00605 03014 | | 1 HALTER |
| 12 | 00605 03015 | | 1 SCHEIBE |
| 13 | 10776 00000 00 00 | | 2 LAGERUNG |
| 14 | 00605 04825 | | 2 LAGERUNG |
| 15 | 00605 04563 | | 4 ZUENDKERZE |
| 16 | 00605 37610 | | 1 ZUENDSPULE |
| 17 | 00605 37945 | | 2 KABEL |
| 18 | 00605 37946 | | 1 KABEL |
| 19 | 00605 38409 | | 1 KABEL |
| 20 | 00605 38523 | | 1 ZUENDKABEL |
| 21 | 00135 78311 | | 2 SCHEIBE |

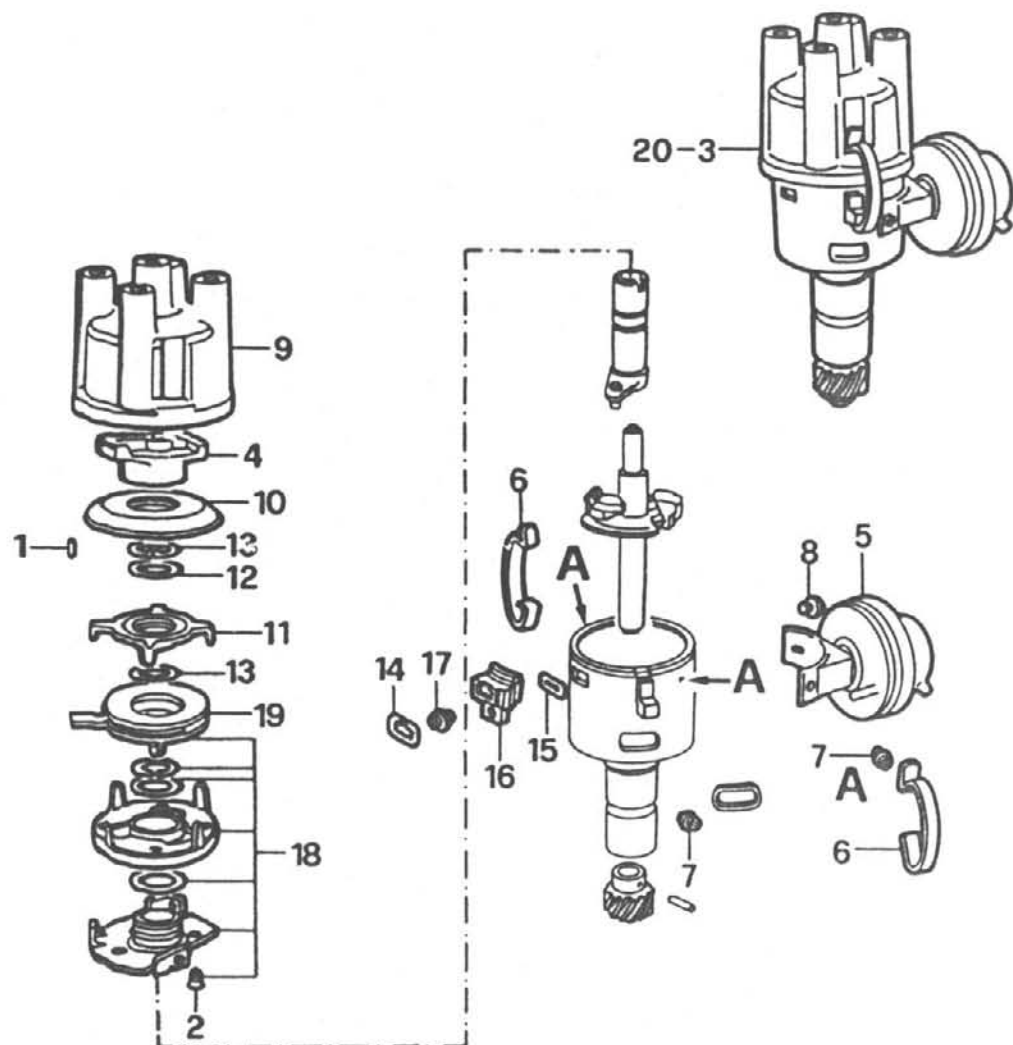

| pos. | TEILNUMMER | ref. | mg. benennung |
|------|-------------------|-------|------------------|
| 1 | 00607 11568 | | 1 BOLZEN |
| 2 | 00099 34657 | | 3 SCHRAUBE |
| 3 | 00605 04816 | □ ● ▲ | 1 ZUENDVERTEILER |
| 4 | 00607 49778 | | 1 SCHLOSS |
| 5 | 00607 49780 | | 1 UNTERDRUCKDOSE |
| 6 | 70540 70000 00 00 | | 1 UNTERDRUCKDOSE |
| 7 | 00607 49781 | | 4 SCHRAUBE |
| 8 | 00607 49782 | | 1 SCHRAUBE |
| 9 | 00965 86846 | | 1 VERTEILERKAPPE |
| 10 | 00099 36005 | | 1 PLATTE |
| 11 | 00607 49783 | | 1 IMPULSGEBER |
| 12 | 00607 49784 | | 1 SCHEIBE |
| 13 | 00607 49785 | | 2 RING |
| 14 | 00607 49786 | | 1 LAGERBOCK |
| 15 | 00607 49787 | | 1 DICHTUNG |
| 16 | 00099 36609 | | 1 KLEMME |
| 17 | 00607 49788 | | 1 SCHRAUBE |
| 18 | 00099 38956 | | 1 ANSCHLAG |
| 19 | 00099 38953 | | 1 WICKLUNG |
| 20 | 00605 43578 | □ | 1 ZUENDVERTEILER |

□ c.c. 1.3 95R.O.N.

● c.c. 1.7

▲ c.c. 1.3

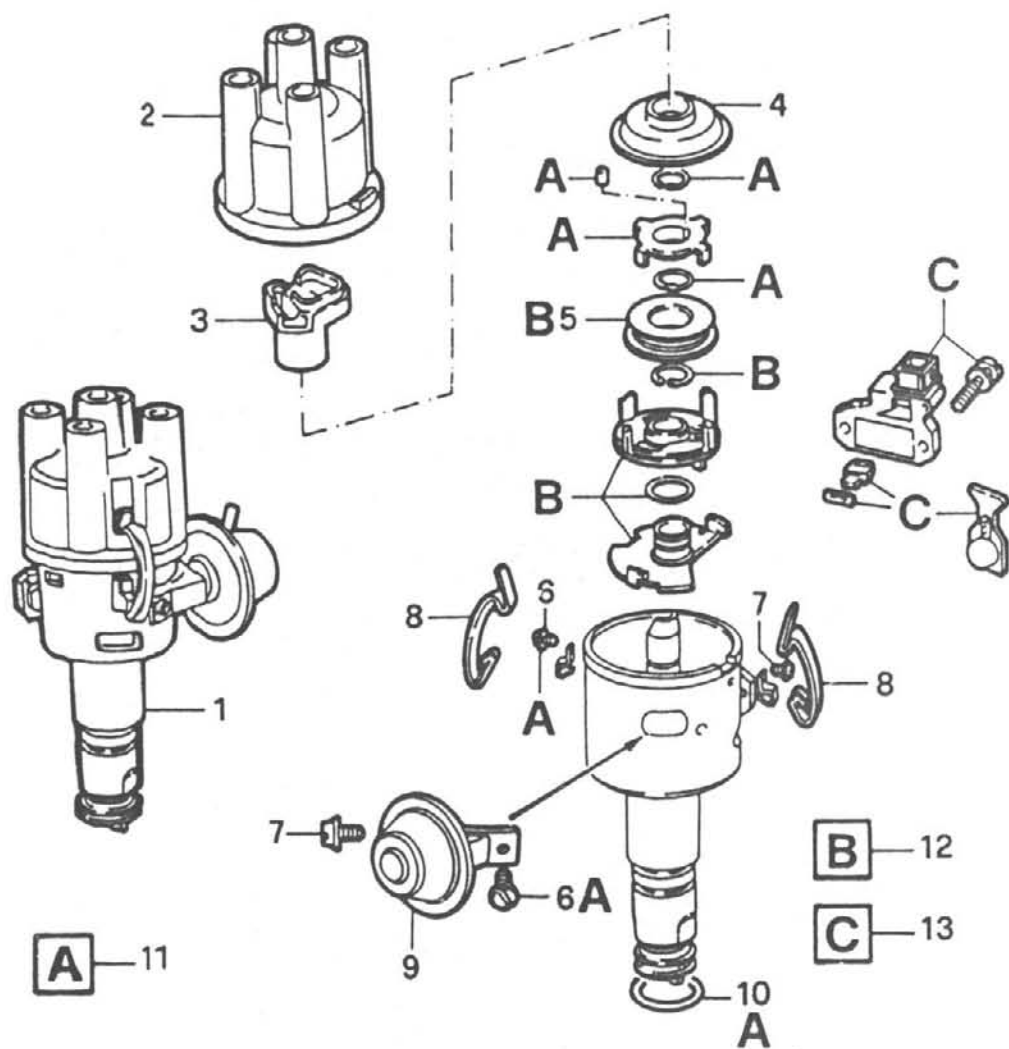

| pos. | TEILNUMMER | ref. | mg. benennung |
|------|-------------------|------|------------------|
| 1 | 00966 09890 | ≡ | 1 VERTEILER |
| 2 | 00823 05237 | | 1 VERTEILERKAPPE |
| 3 | 00607 55007 | | 1 ROTOR |
| 4 | 00607 52001 | | 1 STAUBSCHUTZ |
| 5 | 00607 55011 | | 1 WICKLUNG |
| 6 | 00607 55006 | | 2 SCHRAUBE |
| 7 | 00607 55005 | | 2 SCHRAUBE |
| 8 | 19517 05011 00 06 | | 2 FEDER |
| 9 | 00607 55009 | | 1 REGLERGRUPPE |
| 10 | 00607 55008 | | 1 RING |
| 11 | 00607 52002 | | 1 REPARATURSATZ |
| 12 | 00607 55010 | | 1 IMPULSGEBER |
| 13 | 00607 55012 | | 1 STEUER GERAET |

H15

SPRINT
Ed. 87
Meccanica

1-1989

BOSCH
I.E.

TAV. 41.21/1

c.c. 32

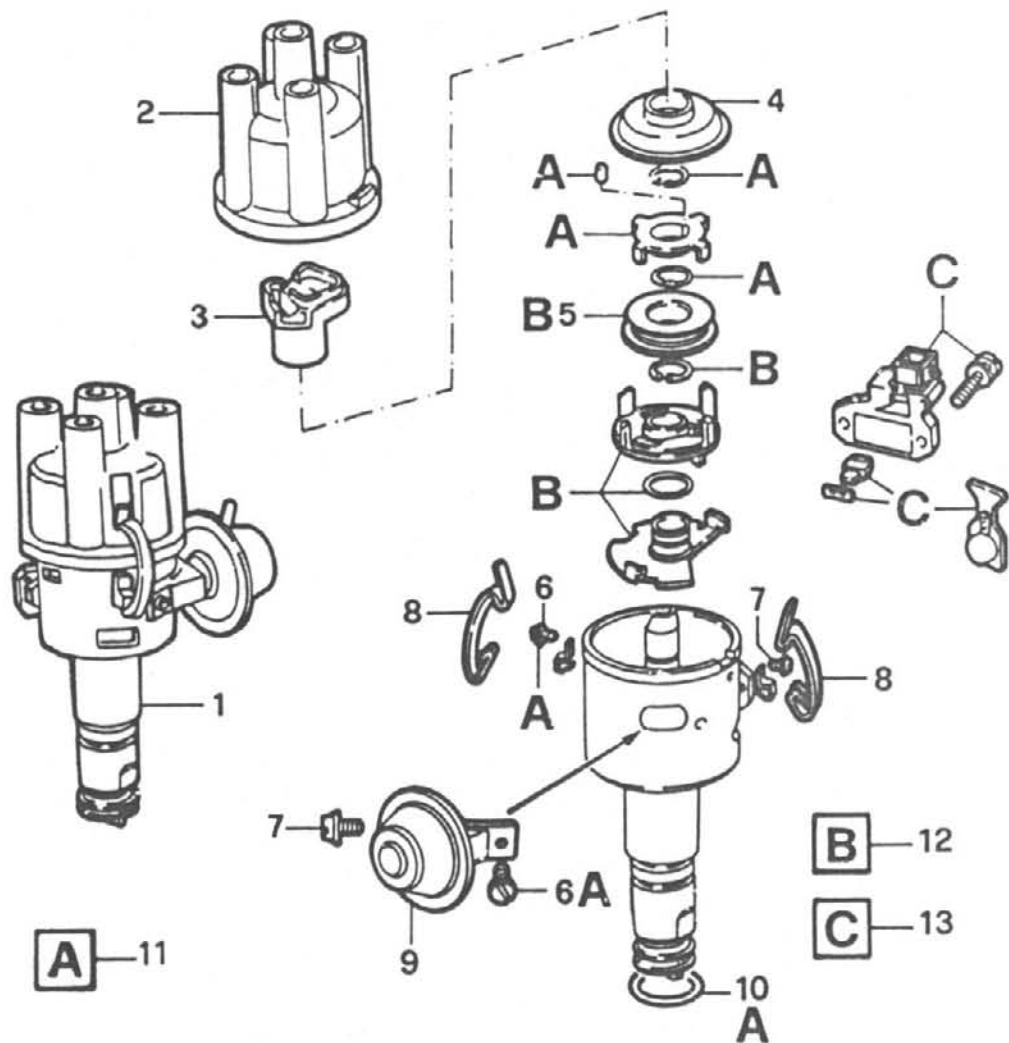

| pos. | TEILNUMMER | ref. | mg. | benennung |
|------|-------------------|------|-----|----------------|
| 1 | 00605 37704 | ⊗ | 1 | VERTEILER |
| 2 | 00823 05237 | | 1 | VERTEILERKAPPE |
| 3 | 00607 55007 | | 1 | ROTOR |
| 4 | 00607 52001 | | 1 | STAUBSCHUTZ |
| 5 | 00607 55011 | | 1 | WICKLUNG |
| 6 | 00607 55006 | | 2 | SCHRAUBE |
| 7 | 00607 55005 | | 2 | SCHRAUBE |
| 8 | 19517 05011 00 06 | | 2 | FEDER |
| 9 | 00607 54014 | | 1 | REGLERGRUPPE |
| 10 | 00607 55008 | | 1 | RING |
| 11 | 00607 52002 | | 1 | REPARATURSATZ |
| 12 | 00607 55010 | | 1 | IMPULSGEBER |
| 13 | 00607 55012 | | 1 | STEUER GERAET |

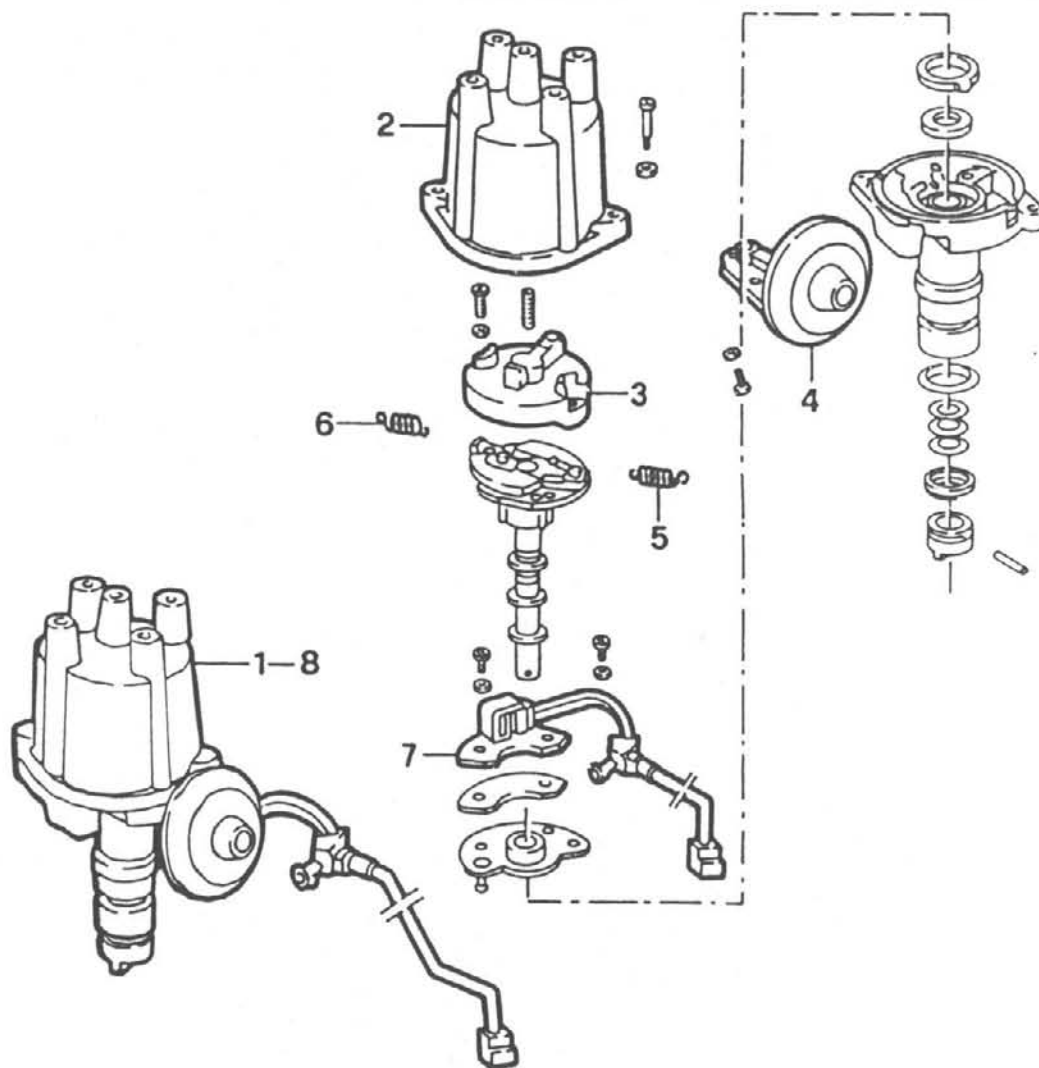

| pos. | TEILNUMMER | ref. | mg. | benennung |
|------|-------------|------|-----|----------------------|
| 1 | 00605 36768 | | 1 | ZJENDVERTEILER |
| 2 | 00607 49768 | | 1 | VERTEILERKAPPE |
| 3 | 00607 49769 | | 1 | VERTEILERLAEUFER |
| 4 | 00607 49770 | | 1 | UNTERDRUCKVERSTELLER |
| 5 | 00607 49772 | | 1 | FEDER |
| 6 | 00607 49773 | | 1 | FEDER |
| 7 | 00607 50221 | | 1 | KONTAKT |
| 8 | 00605 04818 | ■ | 1 | ZUENDVERTEILER |

H17

SPRINT
Ed. 87
Meccanica

1-1989

DUCELLIER

TAV. 41.25/1

c.c. 32

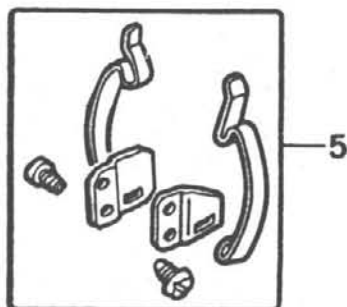
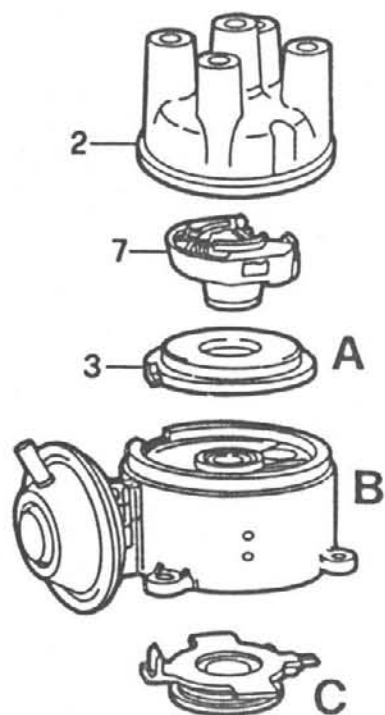
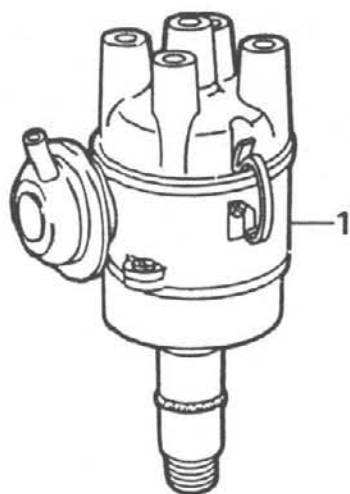

B+C — 6

A+C — 4

| pos. | TEILNUMMER | ref. | mg. benennung |
|------|-------------|------|----------------------|
| 1 | 00605 37108 | | 1 VERTEILER |
| 2 | 00607 49869 | | 1 VERTEILERKAPPE |
| 3 | 00607 50053 | | 1 UNTERBRECHERPLATTE |
| 4 | 00607 50074 | | 1 ZUENDSPULE |
| 5 | 00607 50075 | | 1 KLAMMER |
| 6 | 00607 50077 | | 1 VERTEILERGEAEUSE |
| 7 | 00607 50392 | | 1 VERTEILERLAEUFER |

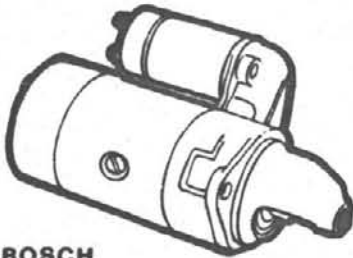
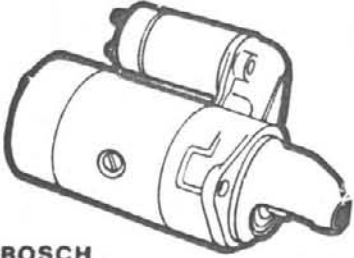
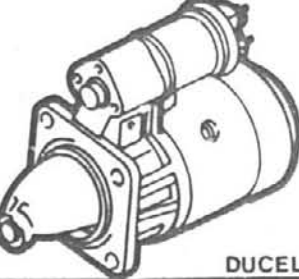
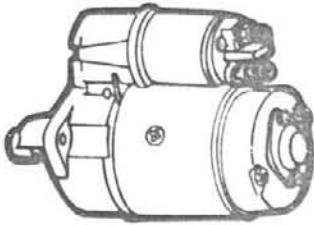
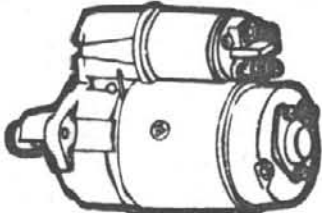
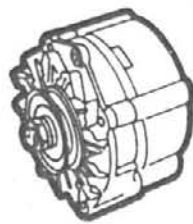
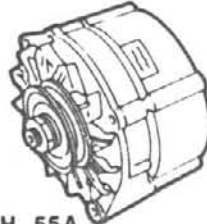
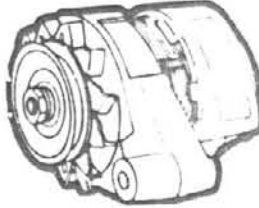
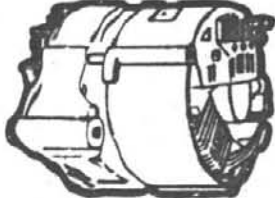
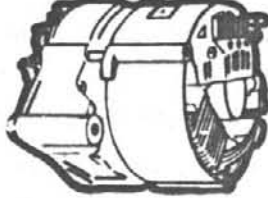
| SPRINT 87 MECCANICA | 9-1987 | 1 TAV 42.01 | 2 TAV 42.01 | 3 TAV 42.05 | 4 TAV 42.08 |
|--|--|---|--|--|--|
|  |  BOSCH |  BOSCH |  DUCELLIER |  MARELLI | |
| |  MARELLI | 6 TAV |  BOSCH |  BOSCH 55A |  DUCELLIER |
| 10 TAV 43.05  MARELLI | 11 TAV 43.05  MARELLI | 12 TAV | 13 TAV | 14 TAV | |
| 15 TAV | 16 TAV | 17 TAV | 18 TAV | 19 TAV | |

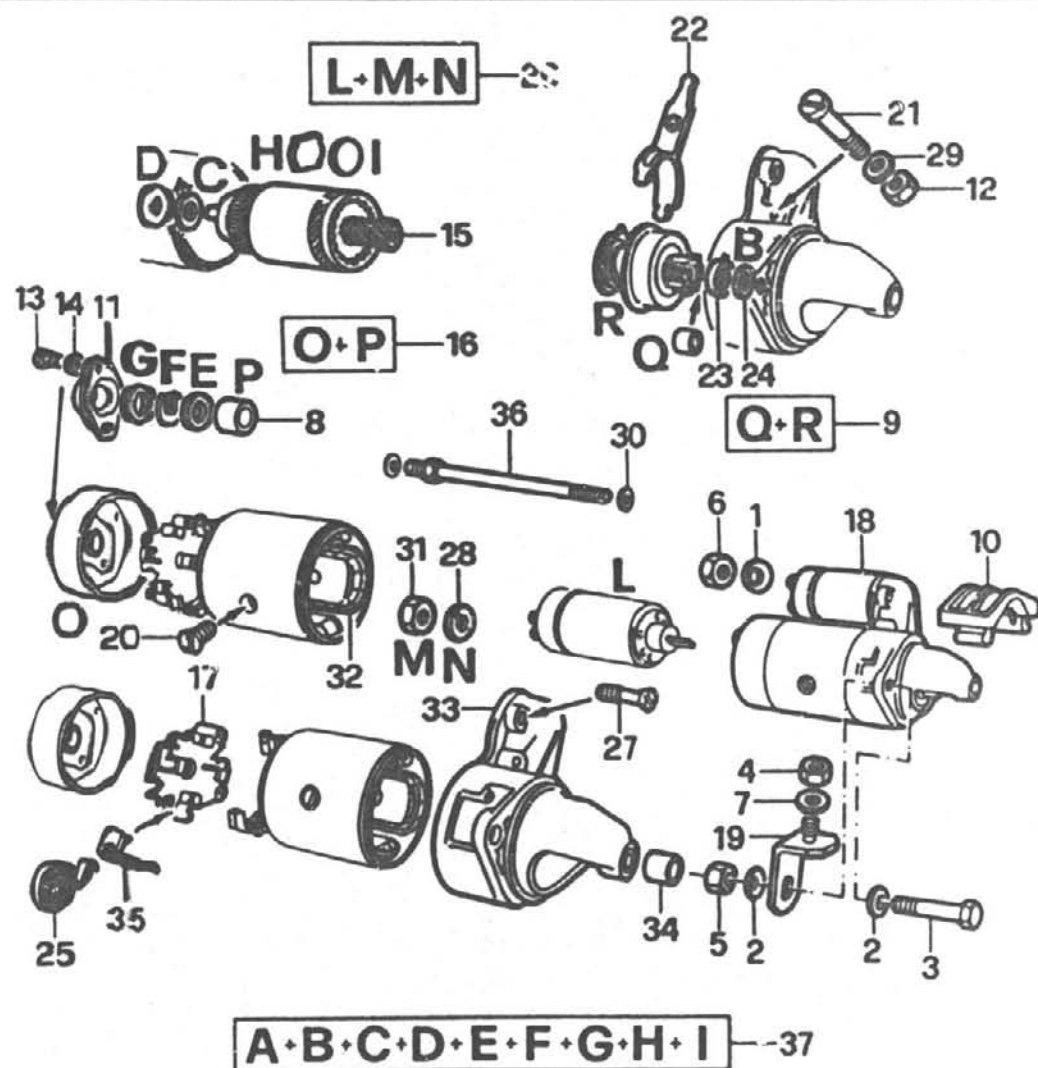

| pos. | TEILNUMMER | ref. | mg. benennung |
|------|-------------------|------|-------------------|
| 1 | 02100 81434 00 00 | | 1 SCHEIBE |
| 2 | 02100 81437 00 00 | | 2 SCHEIBE |
| 3 | 00159 71821 | | 1 SCHRAUBE |
| 4 | 00158 96211 | | 1 MUTTER |
| 5 | 00121 64711 | | 1 MUTTER |
| 6 | 00161 02311 | | 1 MUTTER |
| 7 | 00107 32011 | | 1 SCHEIBE |
| 8 | 00099 20623 | | 1 HUELSE |
| 9 | 00607 11578 | | 1 KEGELRAD |
| 10 | 00605 03102 | | 1 DECKEL |
| 11 | 00607 23799 | | 1 DECKEL |
| 12 | 00607 23806 | | 1 MUTTER |
| 13 | 00607 23808 | | 2 SCHRAUBE |
| 14 | 00607 23809 | | 2 UNTERLEGSCHIEBE |
| 15 | 00099 36598 | | 1 ANKER |
| 16 | 00607 25083 | | 1 LAGERUNG |
| 17 | 00607 25086 | | 1 KONTAKTTRAEGER |
| 18 | 00605 04218 | | 1 MOTOR |
| 19 | 00605 01222 | | 1 HALTER |
| 20 | 00607 48302 | | 4 SCHRAUBE |
| 21 | 00607 48305 | | 1 SCHRAUBE |
| 22 | 00607 48306 | | 1 GABEL |
| 23 | 00607 48310 | | 1 HUELSE |
| 24 | 00607 48311 | | 1 RING |
| 25 | 00607 48315 | | 4 FEDER |



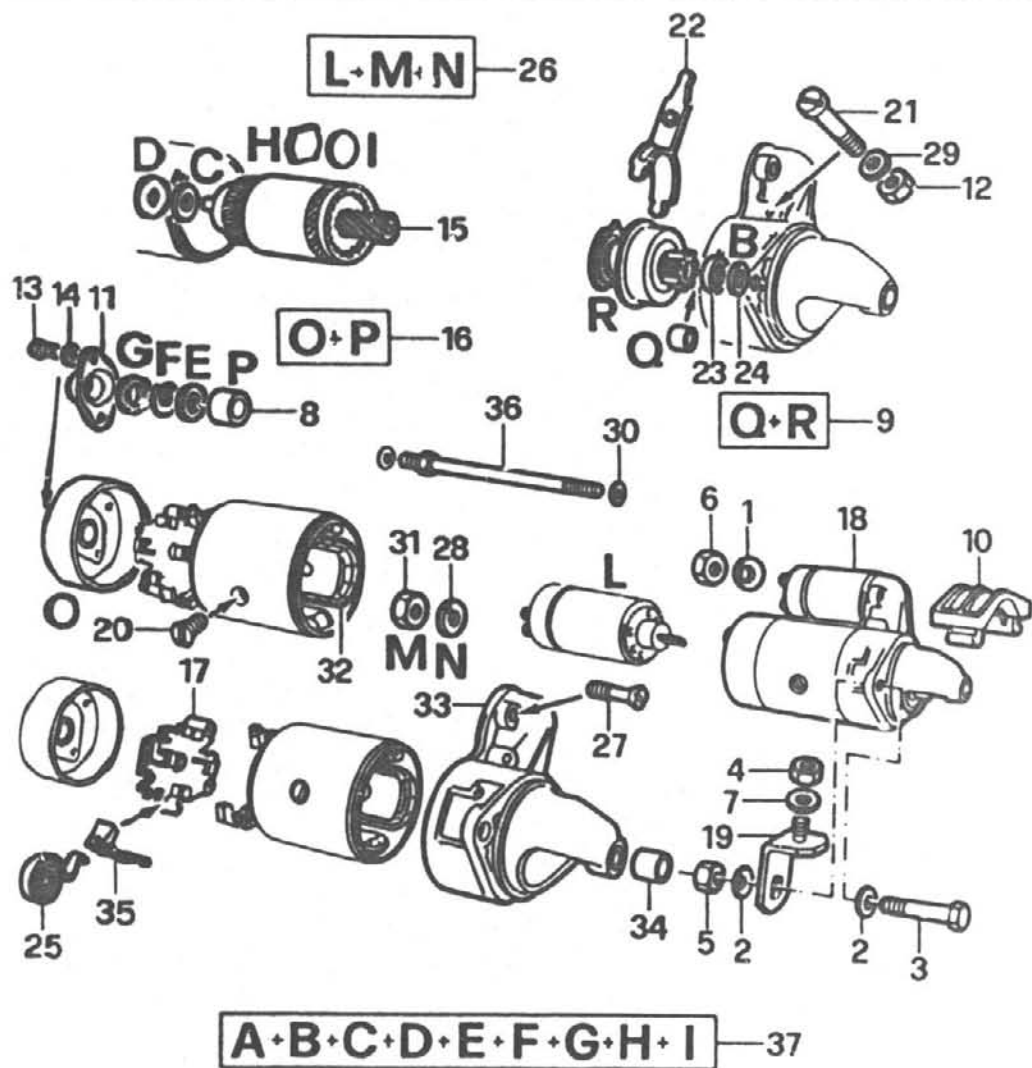

| pos. | TEILNUMMER | ref. | mg. | benennung | ↑ |
|------|-------------------|------|-----|---------------|---|
| 26 | 70019 30000 00 00 | | 1 | ELEKTROMAGNET | |
| 27 | 00607 48320 | | 2 | SCHRAUBE | |
| 28 | 00607 48322 | | 2 | SCHEIBE | |
| 29 | 00607 48409 | | 1 | SCHEIBE | |
| 30 | 00607 48412 | | 2 | SCHEIBE | |
| 31 | 00607 48414 | | 2 | MUTTER | |
| 32 | 00607 48910 | | 1 | WICKLUNG | |
| 33 | 00607 48911 | | 1 | LAGERUNG | |
| 34 | 00099 36616 | | 1 | HUELSE | |
| 35 | 00099 35949 | | 1 | REPARATURSATZ | |
| 36 | 00607 48917 | | 2 | STEBOLZEN | |
| 37 | 00607 48918 | | 1 | EINZELTEILE | |

DUCELLIER

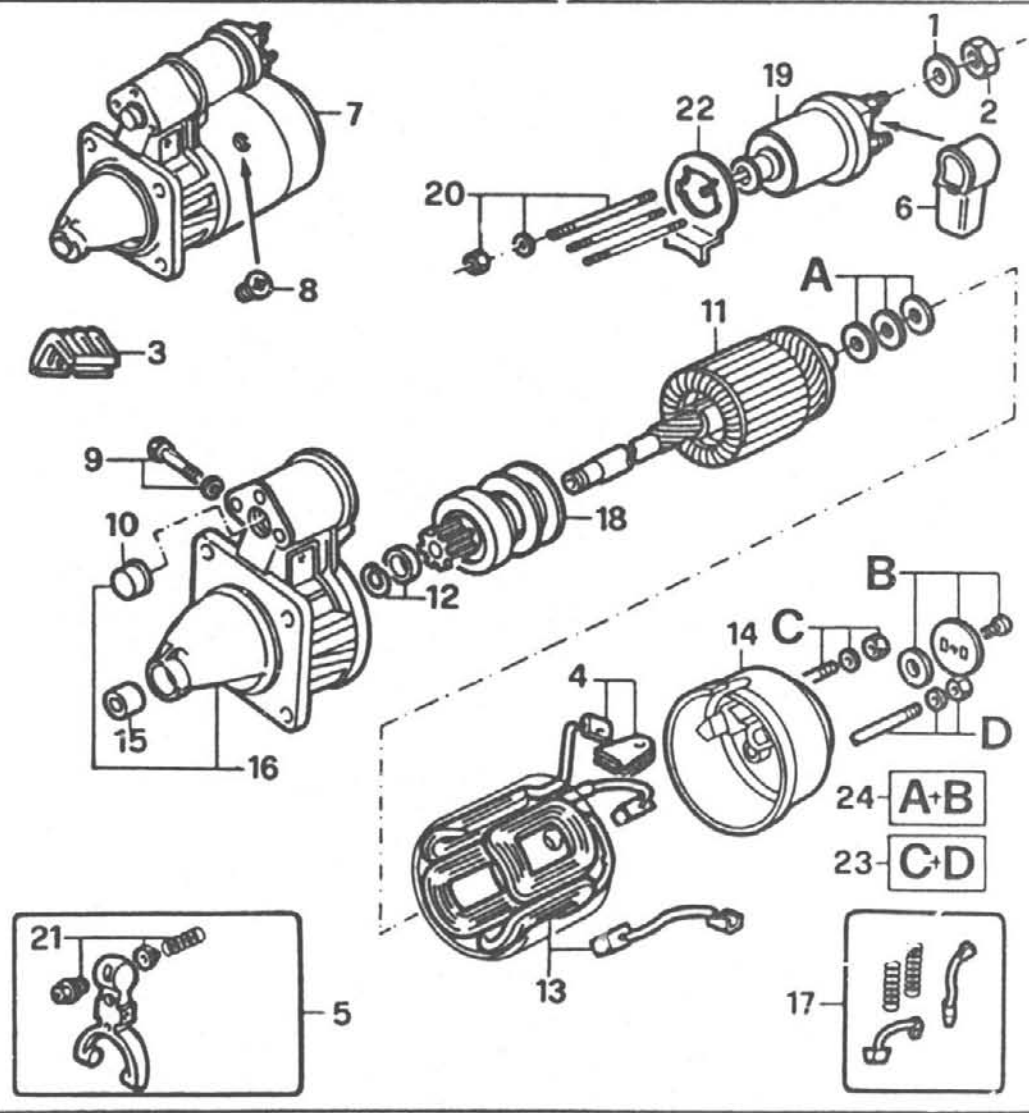

| pos. | TEILNUMMER | ref. | mg. benennung |
|------|-------------------|------|------------------|
| 1 | 02100 81434 00 00 | | 1 SCHEIBE |
| 2 | 00161 02311 | | 1 MUTTER |
| 3 | 00605 03102 | | 1 DECKEL |
| 4 | 00607 25100 | | ISOLIERSTOFF |
| 5 | 00607 25103 | | 1 GABEL |
| 6 | 00607 38104 | | 1 KAPPE |
| 7 | 00605 04218 | | 1 ANLASSER |
| 8 | 00607 48367 | | 4 SCHRAUBE |
| 9 | 00607 48370 | | 1 ANSCHLAG |
| 10 | 00607 48390 | | 1 STOPFEN |
| 11 | 00607 48971 | | 1 ANKER |
| 12 | 00607 48972 | | 1 HUELSE |
| 13 | 00607 48973 | | 1 WICKLUNG |
| 14 | 00607 48975 | | 1 LAGERUNG |
| 15 | 00607 48976 | | 1 HUELSE |
| 16 | 00607 48977 | | 1 LAGERUNG |
| 17 | 00607 48978 | | 1 SCHLOSS |
| 18 | 00607 48979 | | 1 KEGELRAD |
| 19 | 00607 48980 | | 1 ELEKTROMAGNET |
| 20 | 00607 48981 | | 1 UNTERDRUCKDOSE |
| 21 | 00607 48982 | | 1 SATZ |
| 22 | 00607 48984 | | 1 PLATTE |
| 23 | 00607 48985 | | 1 SICHERUNGSSATZ |
| 24 | 00607 48986 | | 1 SICHERUNGSSATZ |

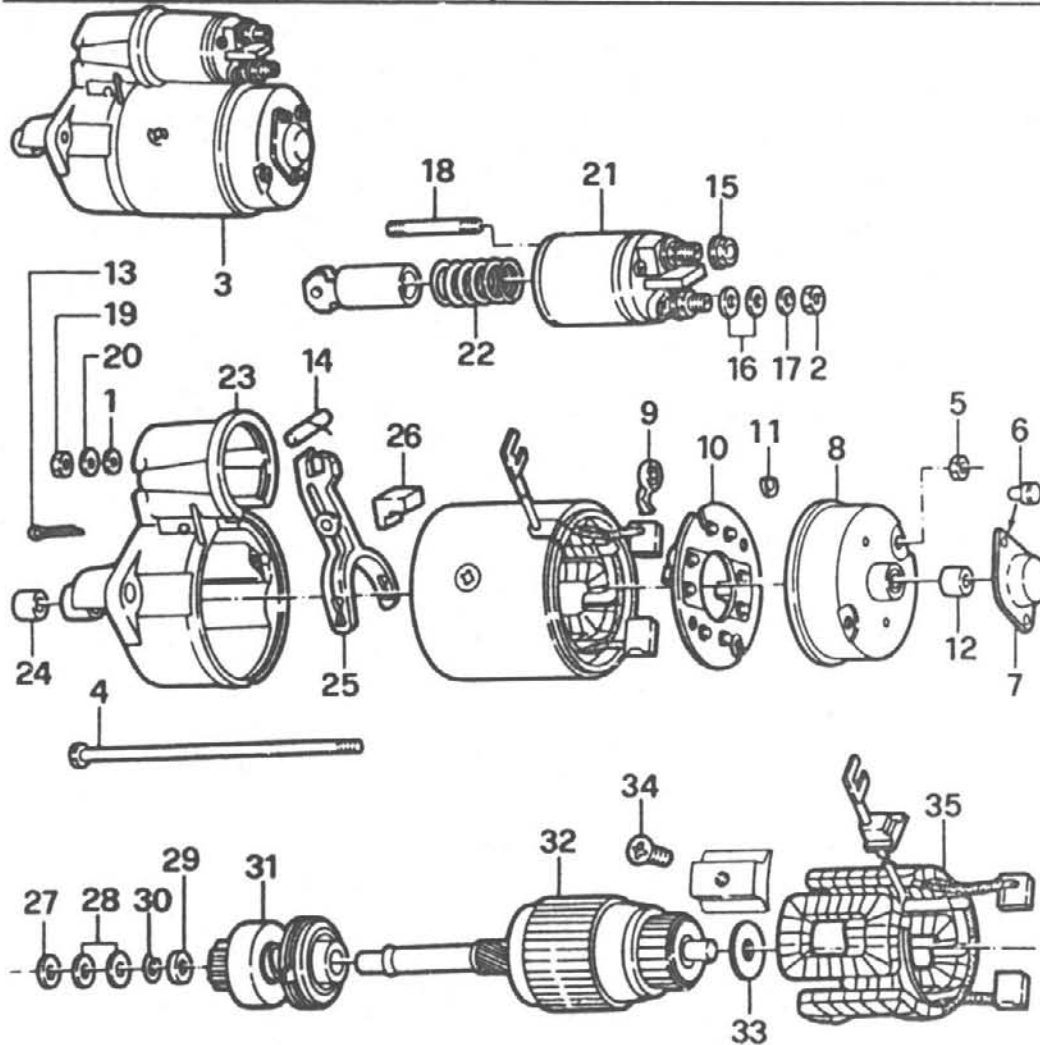

| pos. | TEILNUMMER | ref. | mg. benennung |
|------|-------------|------|-----------------|
| 1 | 00099 33301 | | 1 SCHEIBE |
| 2 | 00607 24715 | | 1 MUTTER |
| 3 | 00605 04218 | | 1 MOTOR |
| 4 | 00607 49505 | | 2 STANGE |
| 5 | 00607 49506 | | 2 MUTTER |
| 6 | 00607 49507 | | 2 SCHRAUBE |
| 7 | 00607 49508 | | 1 TELLER |
| 8 | 00607 49509 | | 1 LAGERUNG |
| 9 | 00607 49510 | | 4 FEDER |
| 10 | 00607 49511 | | 1 PLATTE |
| 11 | 00607 49512 | | 2 ABDECKUNG |
| 12 | 00607 49513 | | 1 BUECHSE |
| 13 | 00607 49514 | | 1 SPLINT |
| 14 | 00607 49515 | | 1 BOLZEN |
| 15 | 00607 49516 | | 1 MUTTER |
| 16 | 00607 49517 | | 2 SCHEIBE |
| 17 | 00607 49518 | | 1 SCHEIBE |
| 18 | 00607 49519 | | 2 STANGE |
| 19 | 00607 49520 | | 2 MUTTER |
| 20 | 00607 49521 | | 2 SCHEIBE |
| 21 | 00607 49522 | | 1 ELEKTROMAGNET |
| 22 | 00607 49524 | | 1 FEDER |
| 23 | 00607 49525 | | 1 LAGERUNG |
| 24 | 00607 49526 | | 1 BUECHSE |
| 25 | 00607 49527 | | 1 HEBEL |



5

SPRINT
Ed. 87
Meccanica

1-1989

MARELLI

TAV. 42.08

c.c. 32

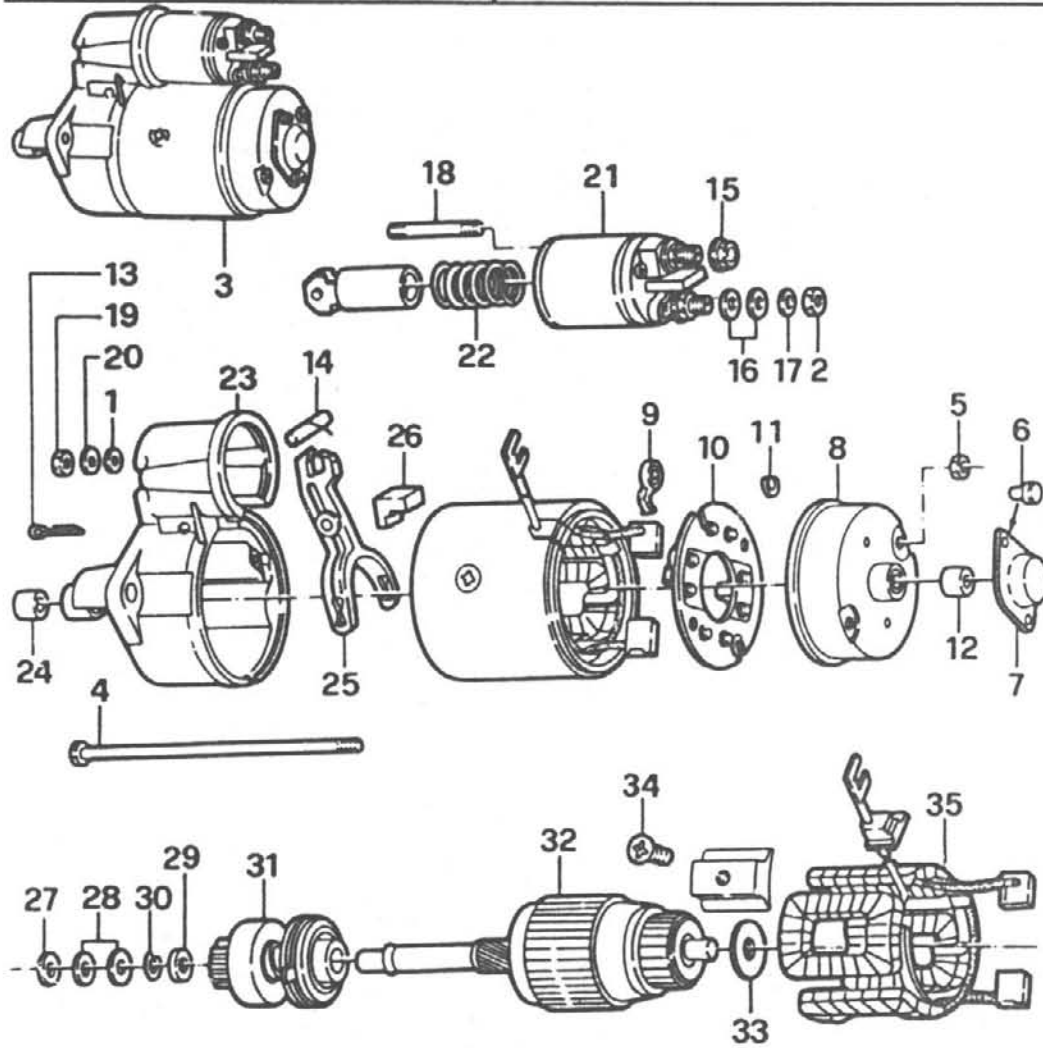

| pos. | TEILNUMMER | ref. | mg. | benennung | ↑ |
|------|-------------|------|-----|-----------|---|
| 26 | 00607 49528 | | 1 | STOPFEN | |
| 27 | 00607 49529 | | 1 | SCHEIBE | |
| 28 | 00607 49530 | | 2 | SCHEIBE | |
| 29 | 00607 49531 | | 1 | RING | |
| 30 | 00607 49532 | | 1 | RING | |
| 31 | 00607 49533 | | 1 | KUPPLUNG | |
| 32 | 00607 49534 | | 1 | ANKER | |
| 33 | 00607 49535 | | 1 | SCHEIBE | |
| 34 | 00607 49536 | | 4 | SCHRAUBE | |
| 35 | 00607 49537 | | 1 | WICKLUNG | |

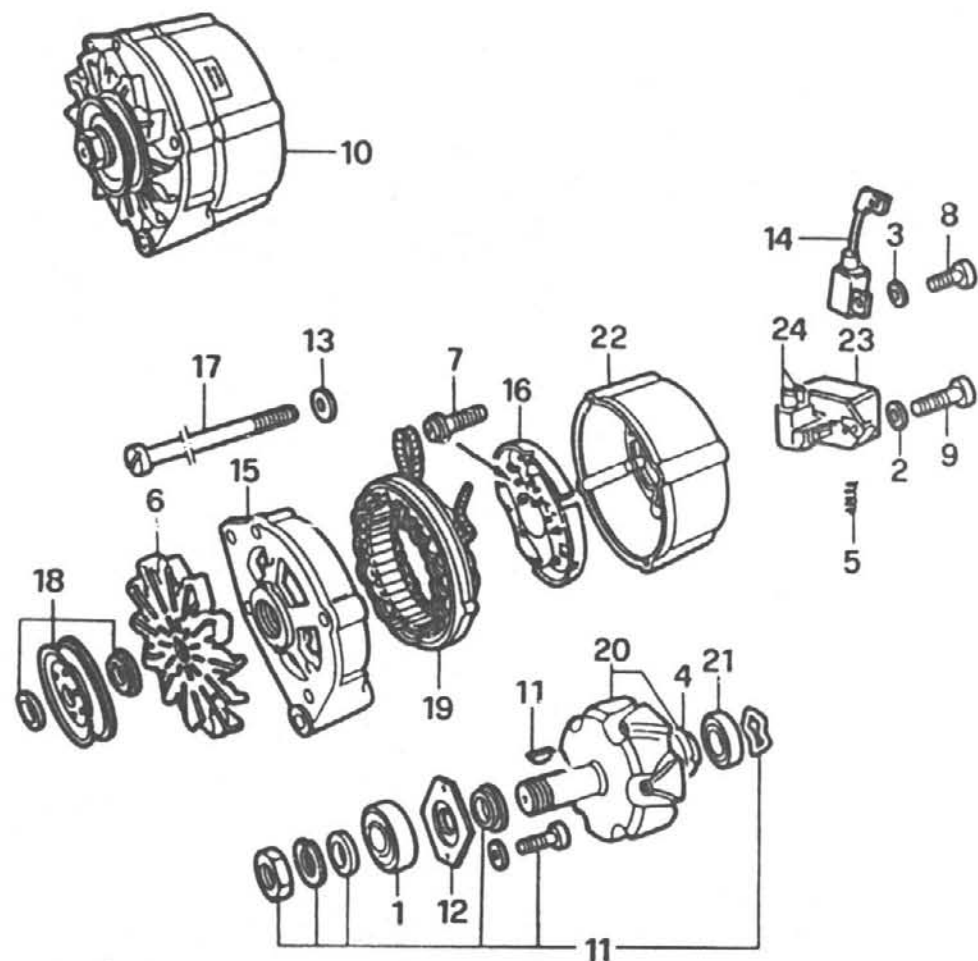

| pos. | TEILNUMMER | ref. | mg. benennung |
|------|-------------------|------|-------------------|
| 1 | 00280 43180 | | 1 LAGER |
| 2 | 00607 23809 | | 2 SCHEIBE |
| 3 | 00607 25940 | | 1 SCHEIBE |
| 4 | 00607 25942 | | 1 RING |
| 5 | 00607 32887 | | 2 FEDER |
| 6 | 00607 32893 | | 1 WINDFLUEGEL |
| 7 | 00607 35999 | | 4 SCHRAUBE |
| 8 | 00099 41111 | | 1 SCHRAUBE |
| 9 | 00607 36004 | | 1 SCHRAUBE |
| 10 | 00605 04827 | | 1 LICHTMASCHINE |
| 11 | 00607 48327 | | 1 REPARATURSATZ |
| 12 | 00607 48328 | | 1 DECKEL |
| 13 | 00607 48421 | | 4 SCHEIBE |
| 14 | 70127 50000 00 00 | | 1 KONDENSATOR |
| 15 | 00607 49065 | | 1 LAGERUNG |
| 16 | 00607 49249 | | 1 DIODENPLATTE |
| 17 | 00607 49251 | | 4 SCHRAUBE |
| 18 | 00099 38217 | | 1 RIEMENSCHIBE |
| 19 | 00607 49628 | | 1 STATOR |
| 20 | 00607 49981 | | 1 ROTOR |
| 21 | 00099 39572 | | 1 LAGER |
| 22 | 00607 49982 | | 1 LAGERUNG |
| 23 | 70568 40000 00 00 | | 1 REGLERGRUPPE |
| 24 | 70568 50000 00 00 | | 1 BUERSTENTRAEGER |

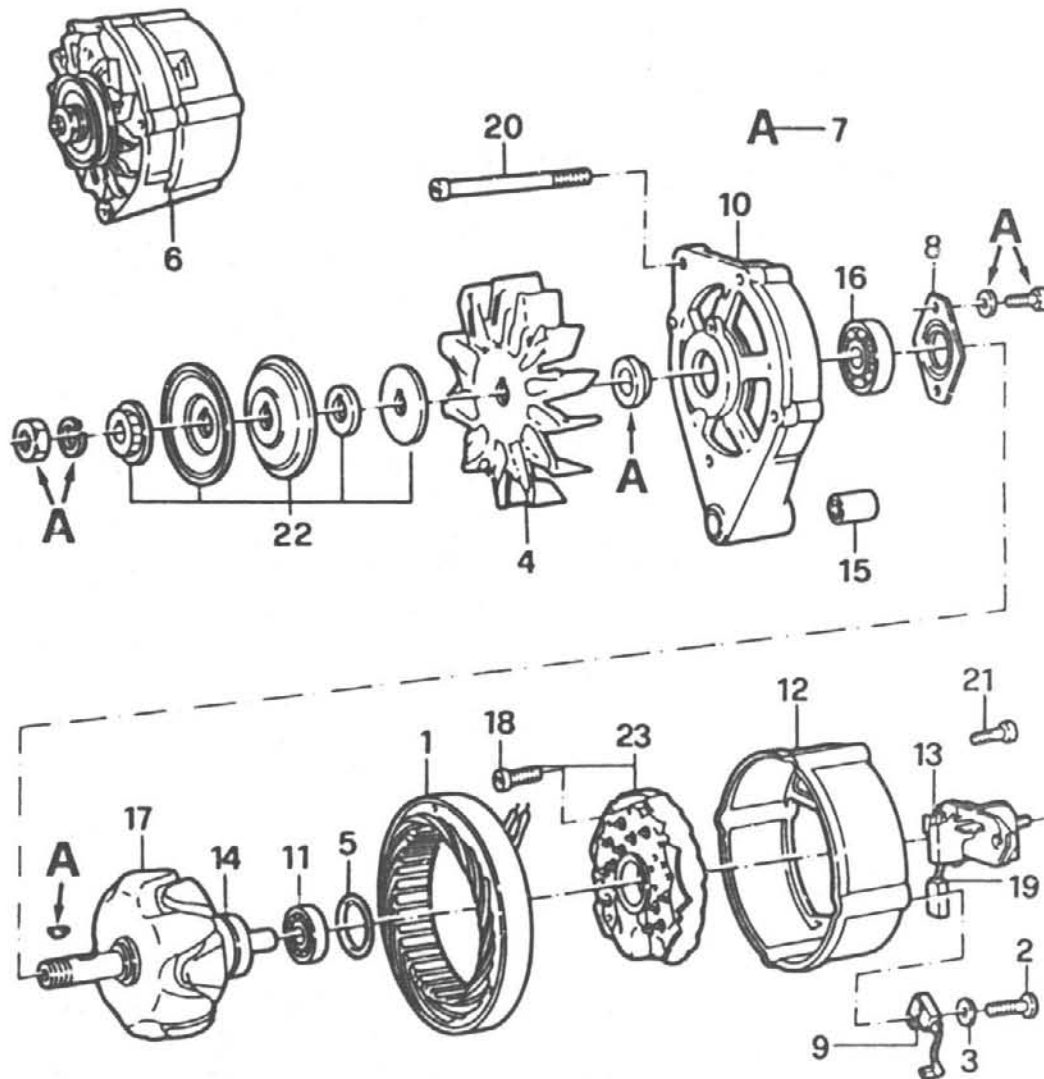

| pos. | TEILNUMMER | ref. | mg. benennung |
|------|-------------------|------|-----------------|
| 1 | 11610 05060 08 05 | | 1 STATOR |
| 2 | 00607 25939 | | 1 SCHRAUBE |
| 3 | 00607 25940 | | 1 SCHEIBE |
| 4 | 11610 05521 03 00 | | 1 WINDFLUEGEL |
| 5 | 00607 32885 | | 1 RING |
| 6 | 00605 04419 | | 1 LICHTMASCHINE |
| 7 | 00607 48327 | | 1 TEILESATZ |
| 8 | 00607 48328 | | 1 PLAETTCHEN |
| 9 | 70127 50000 00 00 | | 1 KONDENSATOR |
| 10 | 00607 49065 | | 1 LAGERUNG |
| 11 | 00099 39572 | | 1 LAGER |
| 12 | 00607 49982 | | 1 LAGERUNG |
| 13 | 70568 40000 00 00 | | 1 REGLERGRUPPE |
| 14 | 00607 50202 | | 1 RING |
| 15 | 00607 50199 | | 1 BUECHSE |
| 16 | 00607 50200 | | 1 LAGER |
| 17 | 00607 50201 | | 1 ROTOR |
| 18 | 00790 74706 | | 4 SCHRAUBE |
| 19 | 70595 70000 00 00 | | 1 REGLERGRUPPE |
| 20 | 00607 50203 | | 4 SCHRAUBE |
| 21 | 00790 75883 | | 2 SCHRAUBE |
| 22 | 70596 00000 00 00 | | 1 REPARATURSATZ |
| 23 | 00099 39571 | | 1 DIODENPLATTE |

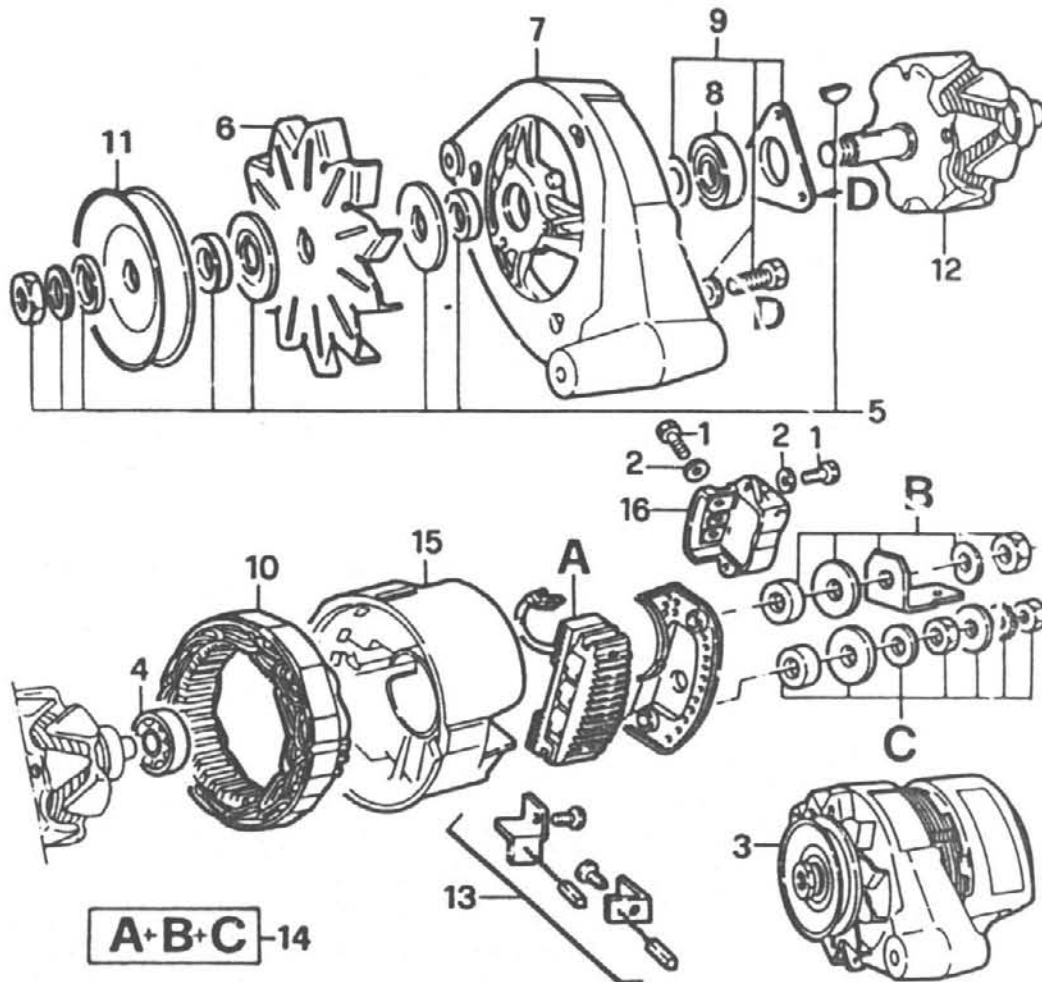

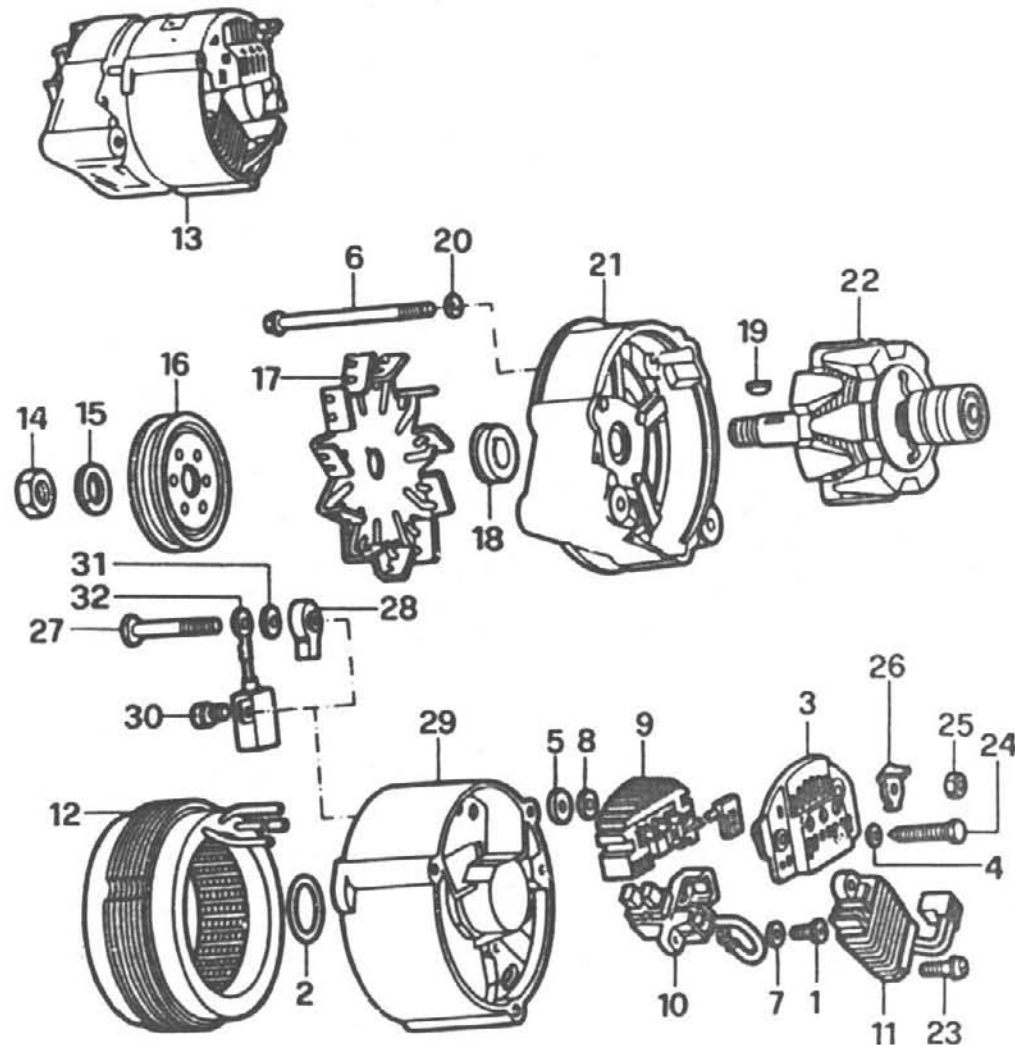

| pos. | TEILNUMMER | ref. | mg. benennung |
|------|-------------|------|--------------------|
| 1 | 00104 44613 | | 5 SCHRAUBE |
| 2 | 00135 79070 | | 5 SCHEIBE |
| 3 | 00605 04827 | | 1 LICHTMASCHINE |
| 4 | 00607 48402 | | 1 LAGER |
| 5 | 00607 48987 | | 1 ANSCHLAG |
| 6 | 00607 48989 | | 1 WINDFLUEGEL |
| 7 | 00607 48991 | | 1 LAGERUNG |
| 8 | 00099 40727 | | 1 LAGER |
| 9 | 00607 48992 | | 1 RING |
| 10 | 00607 48994 | | 1 STATOR |
| 11 | 00099 38217 | | 1 RIEMENSCHIEBE |
| 12 | 00607 49596 | | 1 ROTOR |
| 13 | 00607 49597 | | 1 BUEHRSTENTRAEGER |
| 14 | 00607 49598 | | 1 BUEHRSTENTRAEGER |
| 15 | 00607 49599 | | 1 DECKEL |
| 16 | 00607 49600 | | 1 REGLERGRUPPE |

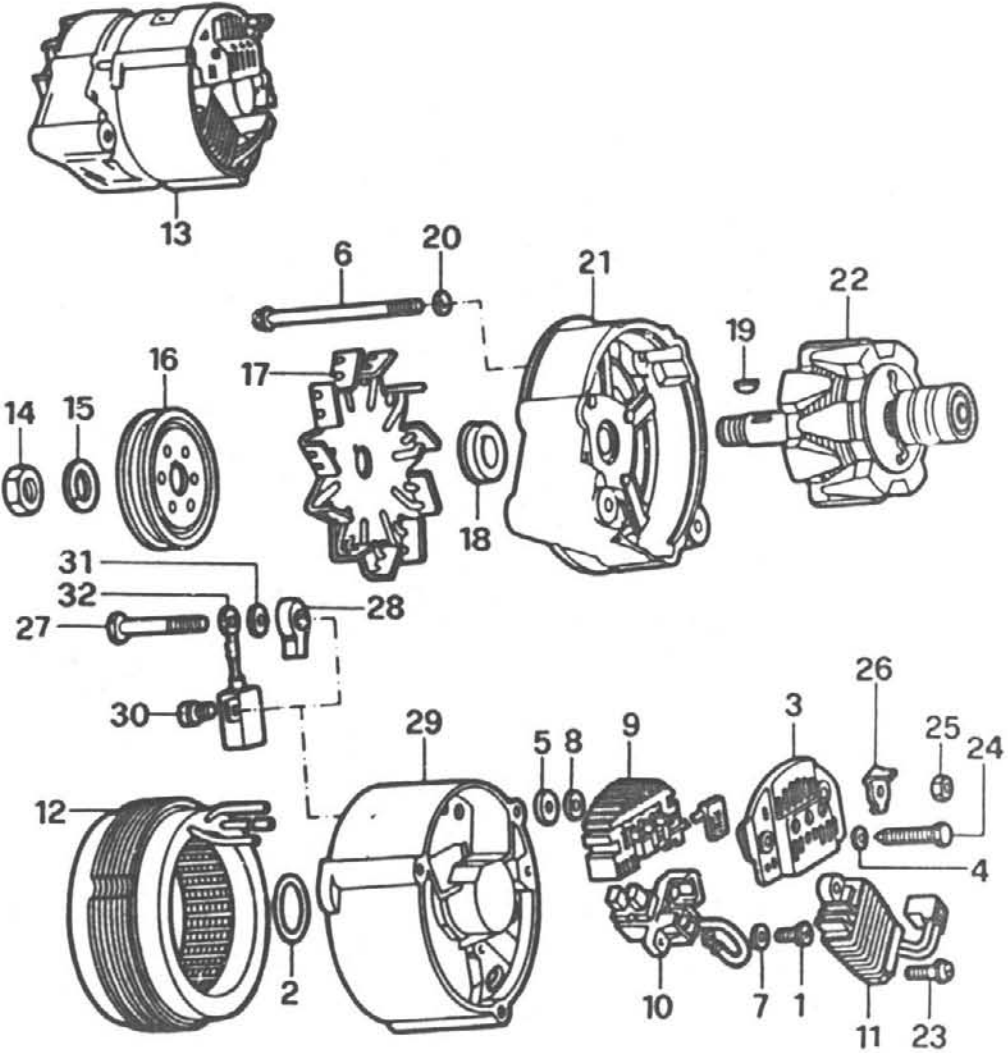

| pos. | TEILNUMMER | ref. | mg. benennung |
|------|-------------------|------|-------------------|
| 1 | 00132 68018 | | 1 SCHRAUBE |
| 2 | 00144 54380 | | 1 ABDICHTUNG |
| 3 | 029P3 72200 00 00 | | 1 SCHUTZ |
| 4 | 09933 30100 00 00 | | 1 SCHEIBE |
| 5 | 09934 59000 00 00 | | 1 SCHEIBE |
| 6 | 09934 59100 00 00 | | 3 SCHRAUBE |
| 7 | 09934 59200 00 00 | | 1 SCHEIBE |
| 8 | 09934 59300 00 00 | | 1 SCHEIBE |
| 9 | 09934 59500 00 00 | | 1 DIODENPLATTE |
| 10 | 09983 35900 00 00 | | 1 BUERSTENTRAEGER |
| 11 | 09983 71600 00 00 | | 1 REGLERGRUPPE |
| 12 | 09983 71800 00 00 | | 1 STATOR |
| 13 | 00605 04827 | | 1 LICHTMASCHINE |
| 14 | 00607 49570 | | 1 MUTTER |
| 15 | 00607 49571 | | 1 SCHEIBE |
| 16 | 00607 49572 | | 1 RIEMENSCHLEIBE |
| 17 | 00607 49573 | | 1 WINDFLUEGEL |
| 18 | 00607 49574 | | 1 ABSTANDSTUECK |
| 19 | 00607 49575 | | 1 ZUNGE |
| 20 | 00607 49576 | | 3 SCHEIBE |
| 21 | 00607 49577 | | 1 LAGERUNG |
| 22 | 00607 49578 | | 1 ROTOR |
| 23 | 00607 49579 | | 2 SCHRAUBE |
| 24 | 00607 49580 | | 1 SCHRAUBE |
| 25 | 00607 49581 | | 1 MUTTER |

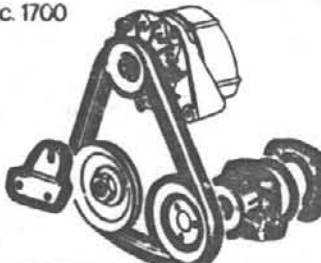
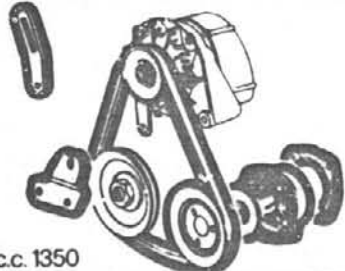
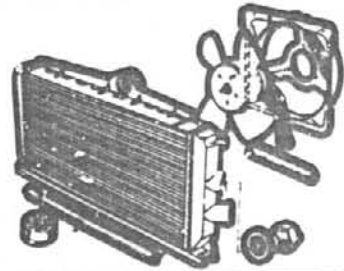
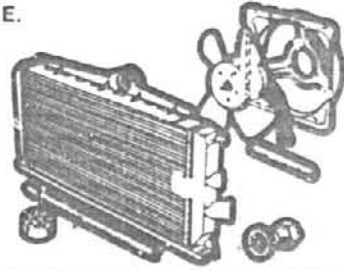
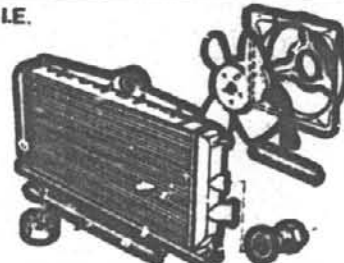
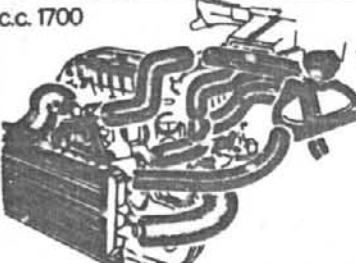
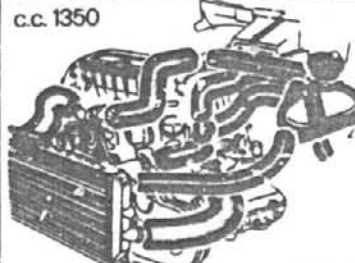
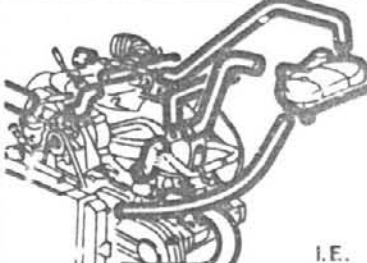

| pos. | TEILNUMMER | ref. | mg. benennung | ↑ |
|------|-------------|------|----------------|---|
| 26 | 00607 49583 | | 1 STIFT | |
| 27 | 00607 49584 | | 1 SCHRAUBE | |
| 28 | 00607 49535 | | 1 ISOLIERSTOFF | |
| 29 | 00607 49586 | | 1 LAGERUNG | |
| 30 | 00607 49587 | | 1 SCHRAUBE | |
| 31 | 00607 49588 | | 1 PLAETTCHEN | |
| 32 | 00607 49589 | | 1 KONDENSATOR | |

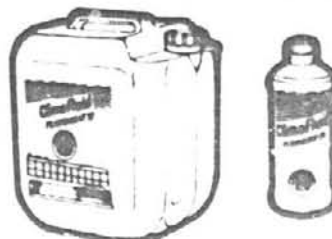
| | | | | | |
|---|--|---|--|--|----------|
| SPRINT 87 MECCANICA | 1-1988 | 1 | 2 | 3 | 4 |
| J | c.c. 1700  |  c.c. 1350 |  | I.E.  | |
| 5 I.E.  | 6 | 7 c.c. 1700  | 8 c.c. 1350  | 9  I.E. | |
| 10 | 11 | 12  | 13  | 14  | |
| 15 | 16 | 17 | 18 | 19 | |

J₁

SPRINT
Ed. 87
Meccanica

1-1989

c.c. 1.7

TAV. 04.00/1

c.c. 32

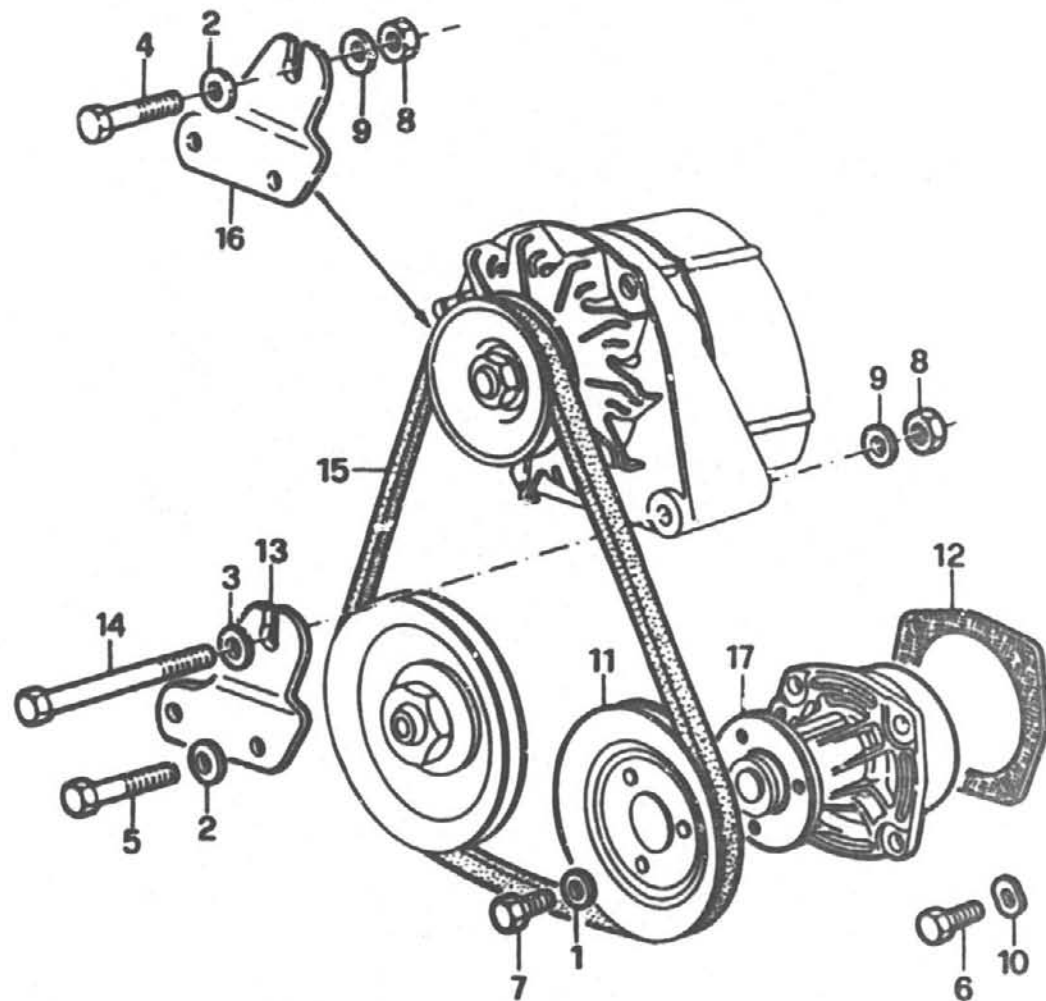

| pos. | TEILNUMMER | ref. | mg. benennung |
|------|------------------------------|------|----------------|
| 1 | 00111 94379 | 3 | SCHEIBE |
| 2 | 02100 81434 00 00 | 4 | SCHEIBE |
| 3 | 02100 81437 00 00 | 4 | SCHEIBE |
| 4 | 02105 02008 00 00 | 1 | SCHRAUBE |
| 5 | 02105 02010 00 00 | 3 | SCHRAUBE |
| 6 | 00151 15621 | 4 | SCHRAUBE |
| 7 | 00109 79421 | 3 | SCHRAUBE |
| 8 | 00161 00811 | 2 | MUTTER |
| 9 | 00107 32211 | 2 | SCHEIBE |
| 10 | 00126 01379 | 4 | SCHEIBE |
| 11 | 00605 02909 | 1 | RIEMENSCHLEIBE |
| 12 | 00605 03080 | 1 | DICHTUNG |
| 13 | 00605 17625 | 1 | HALTER |
| 14 | 00605 04831 | 1 | SCHRAUBE |
| 15 | 00605 04835 | 1 | RIEMEN |
| 16 | 00605 04829 | 1 | HALTER |
| 17 | 00605 04407 | 1 | PUMPE |

J₂

SPRINT
Ed. 87
Meccanica

1-1989

c.c. 1.3

TAV. 04.00

c.c. 32

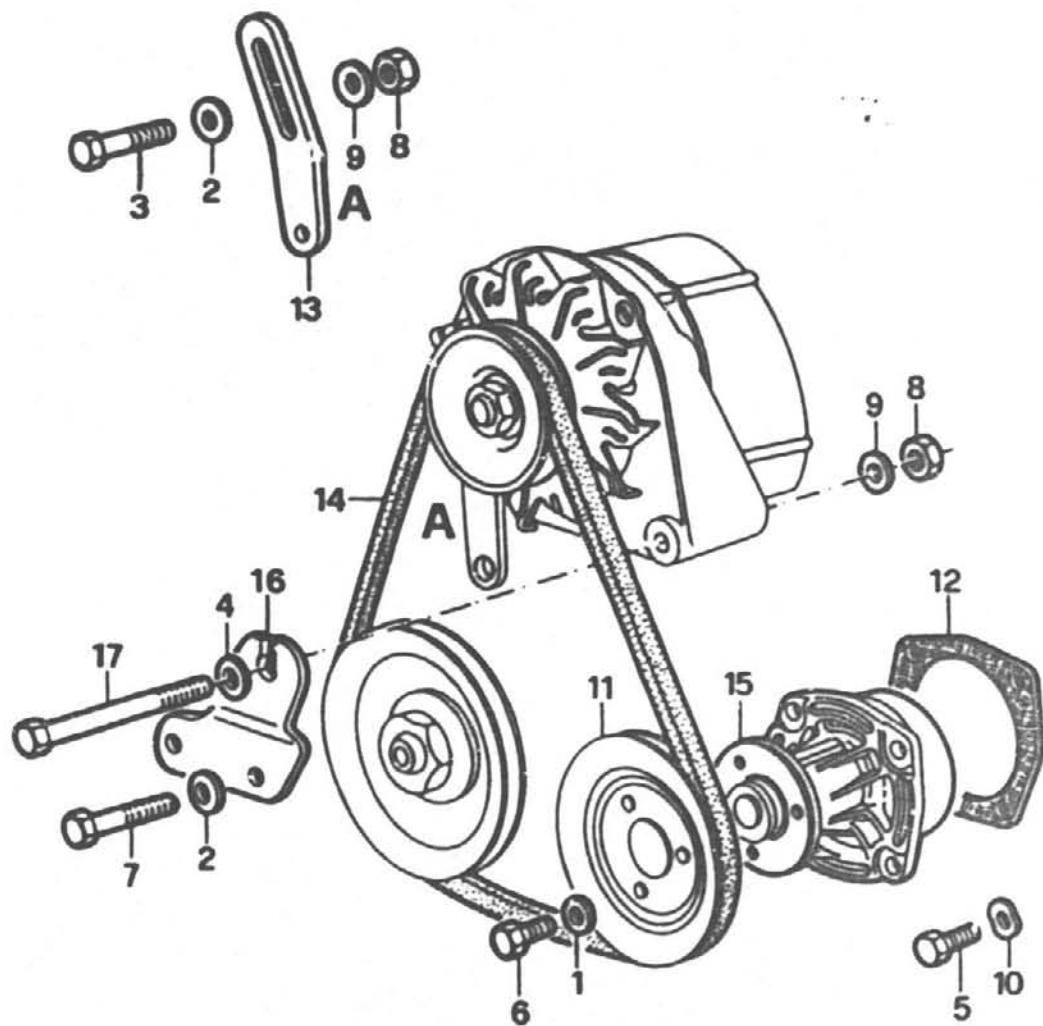

| pos. | TEILNUMMER | ref. | mq. | benennung |
|------|------------------------------|------|-----|----------------|
| 1 | 00111 94373 | | 3 | SCHEIBE |
| 2 | 02100 81434 00 00 | | 4 | SCHEIBE |
| 3 | 02105 02008 00 30 | | 1 | SCHRAUBE |
| 4 | 02100 81437 00 00 | | 1 | SCHEIBE |
| 5 | 00151 15621 | | 4 | SCHRAUBE |
| 6 | 00109 79421 | | 3 | SCHRAUBE |
| 7 | 02105 02010 00 00 | | 2 | SCHRAUBE |
| 8 | 00161 00811 | | 2 | MUTTER |
| 9 | 00107 32211 | | 2 | SCHEIBE |
| 10 | 00126 01379 | | 4 | SCHEIBE |
| 11 | 00605 02909 | | 1 | RIEMENSCHLEIBE |
| 12 | 00605 03060 | | 1 | DICHTUNG |
| 13 | 00605 04830 | | 1 | PLATTE |
| 14 | 00605 04835 | | 1 | RIEMEN |
| 15 | 00605 04407 | | 1 | PUMPE |
| 16 | 00605 17625 | | 1 | PLATTE |
| 17 | 00605 04831 | | 1 | SCHRAUBE |

J3

SPRINT
Ed. 87
Meccanica

1-1989

TAV. 04.10

c.c. 32

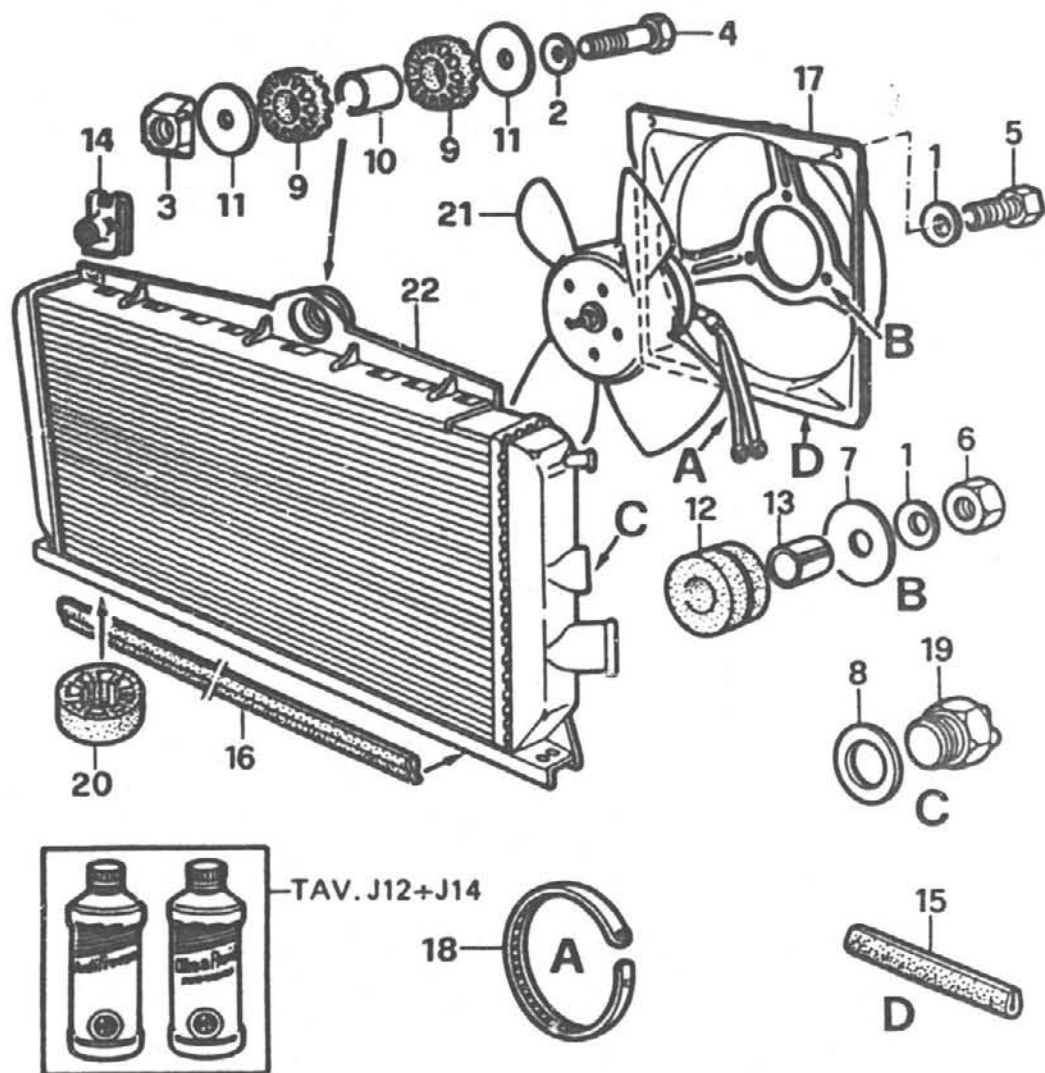

| pos. | TEILNUMMER | ref. | mg. benennung |
|------|-------------------|------|------------------|
| 1 | 02100 81408 00 00 | | 7 SCHEIBE |
| 2 | 02100 81434 00 00 | | 1 SCHEIBE |
| 3 | 00141 93190 | | 1 MUTTER |
| 4 | 00161 36121 | | 1 SCHRAUBE |
| 5 | 02105 32562 00 00 | | 4 SCHRAUBE |
| 6 | 00158 96211 | | 3 MUTTER |
| 7 | 00135 77911 | | 3 SCHEIBE |
| 8 | 00102 61850 | | 1 DICHTUNG |
| 9 | 00605 02936 | | 2 PUFFER |
| 10 | 00605 02937 | | 1 ABSTANDSTUECK |
| 11 | 00605 02938 | | 2 SCHEIBE |
| 12 | 00605 02940 | | 3 ZWISCHENSTUECK |
| 13 | 00605 02967 | | 3 ABSTANDSTUECK |
| 14 | 00605 03003 | | 2 HALTER |
| 15 | 00605 03106 | | 1 DICHTUNG |
| 16 | 00605 17474 | | 1 DICHTUNG |
| 17 | 00605 03395 | | 1 LUFTLEITRAHMEN |
| 18 | 12716 00000 00 00 | | 1 SCHELLE |
| 19 | 00605 03687 | | 1 THERMOKONTAKT |
| 20 | 00605 03741 | | 2 PUFFER |
| 21 | 00605 36148 | | 1 LUEFTER |
| 22 | 00605 04386 | | 1 KUEHLER |

J4

SPRINT
Ed. 87
Meccanica
1-1989

I.E.

TAV. 04.10/5

c.c. 32

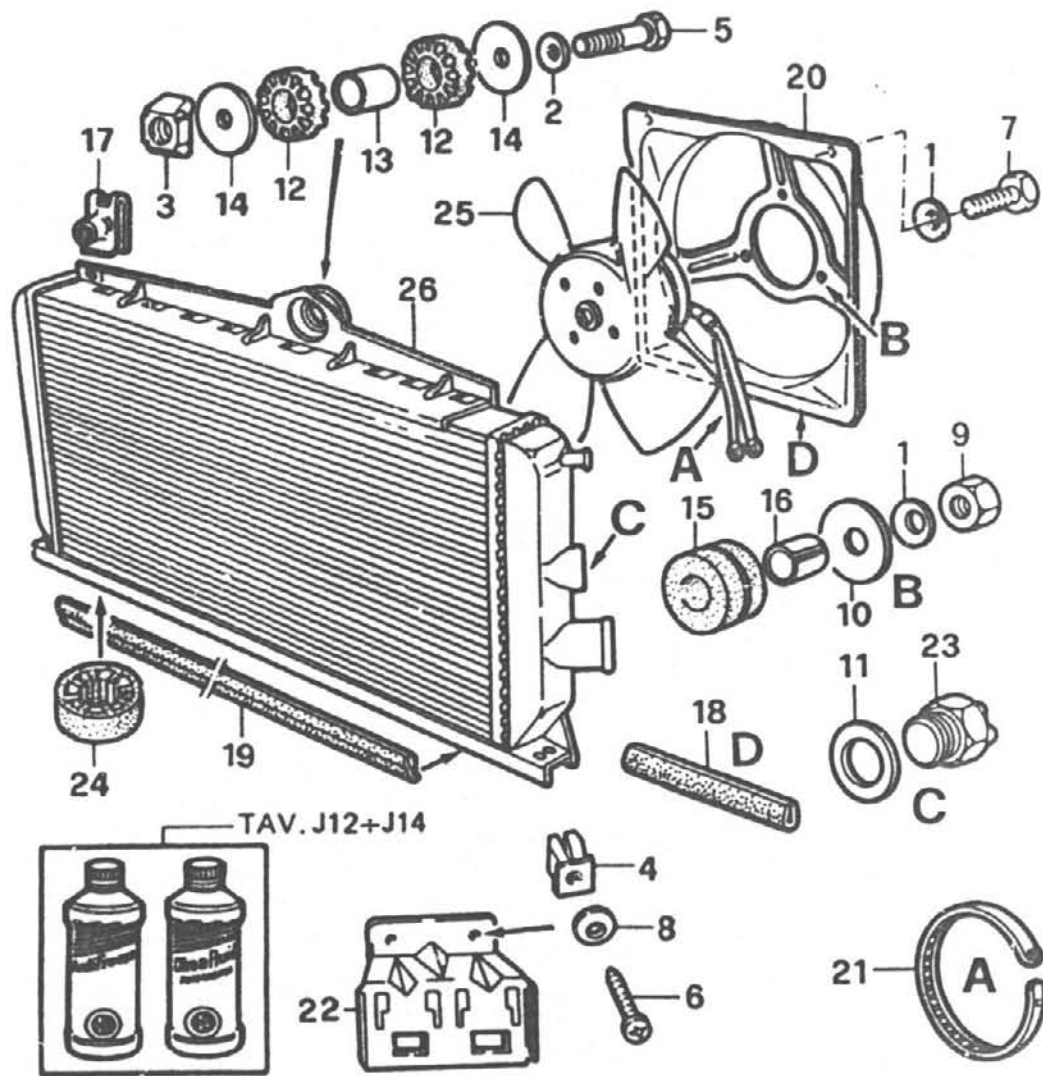

| pos. | TEILNUMMER | ref. | mg. | benennung |
|------|-------------------|------|-----|----------------|
| 1 | 02100 81408 00 00 | | 7 | SCHEIBE |
| 2 | 02100 81434 00 00 | | 1 | SCHEIBE |
| 3 | 00141 93190 | | 1 | MUTTER |
| 4 | 00142 01980 | | 1 | INNENGWINDE |
| 5 | 00161 36121 | | 1 | SCHRAUBE |
| 6 | 02105 16339 00 00 | | 1 | SCHRAUBE |
| 7 | 02105 32562 00 00 | | 4 | SCHRAUBE |
| 8 | 02105 81405 00 00 | | 1 | SCHEIBE |
| 9 | 00158 96211 | | 3 | MUTTER |
| 10 | 00135 77911 | | 3 | SCHEIBE |
| 11 | 00102 61850 | | 1 | DICHTUNG |
| 12 | 00605 02936 | | 2 | PUFFER |
| 13 | 00605 02937 | | 1 | ABSTANDSTUECK |
| 14 | 00605 02938 | | 2 | SCHEIBE |
| 15 | 00605 02940 | | 3 | ZWISCHENSTUECK |
| 16 | 00605 02967 | | 3 | ABSTANDSTUECK |
| 17 | 00605 03003 | | 2 | HALTER |
| 18 | 00605 03106 | | 1 | DICHTUNG |
| 19 | 00605 17474 | | 1 | DICHTUNG |
| 20 | 00605 03395 | | 1 | LUFTLEITRAHMEN |
| 21 | 12716 00000 00 00 | | 1 | SHELLE |
| 22 | 00605 06411 | | 1 | HALTER |
| 23 | 00605 03687 | | 1 | THERMOKONTAKT |
| 24 | 00605 03741 | | 2 | PUFFER |
| 25 | 00605 36148 | | 1 | LUEFTER |



J5

SPRINT
Ed. 87
Meccanica
1-1989

I.E.

TAV. 04.10/5

c.c. 32

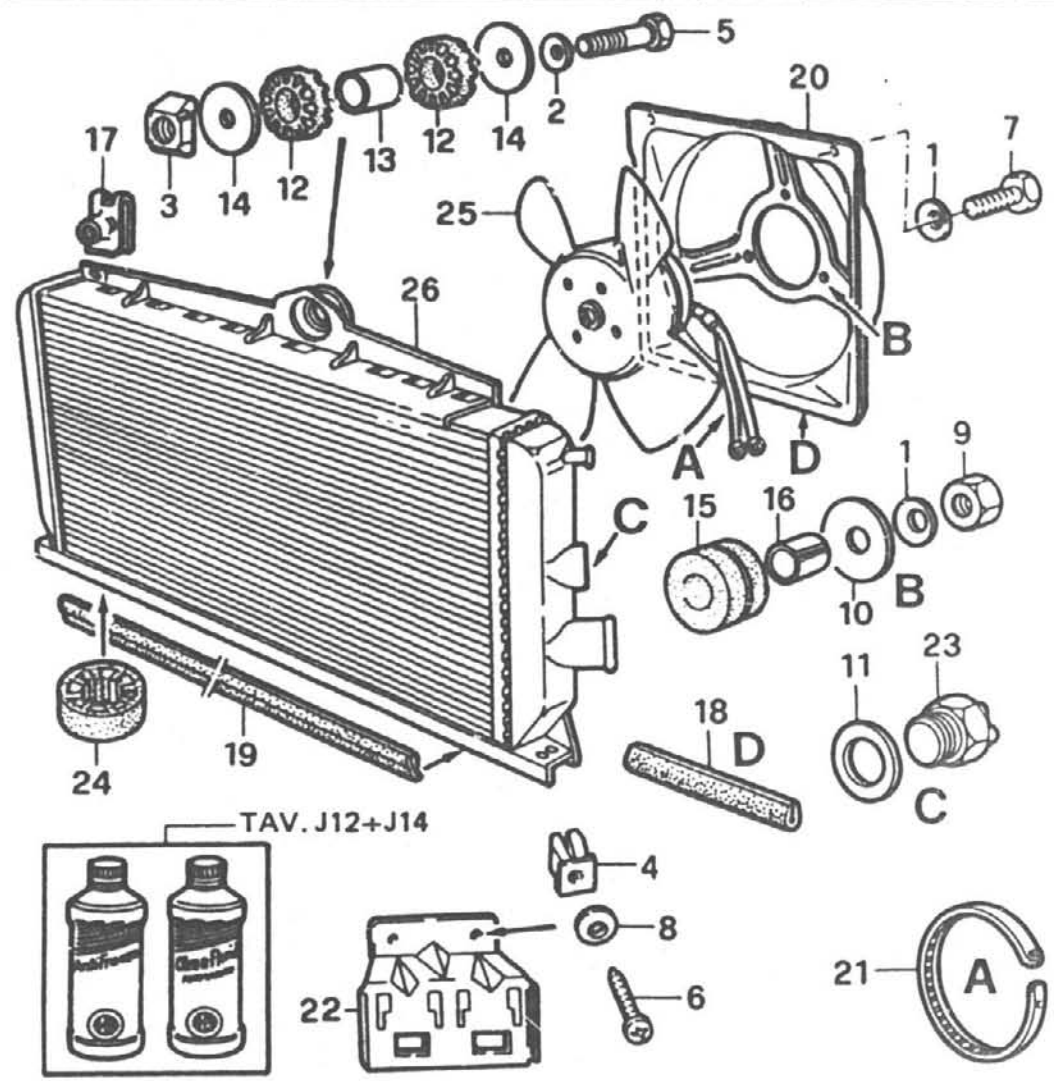

| pos. | TEILNUMMER | ref. | mg. benennung | |
|------|-------------|------|---------------|---|
| 26 | 00605 04386 | | 1 KUEHLER | ↑ |

J7

SPRINT
Ed. 87
Meccanica

1-1989

c.c. 1.7

TAV. 04.11/1

c.c. 32

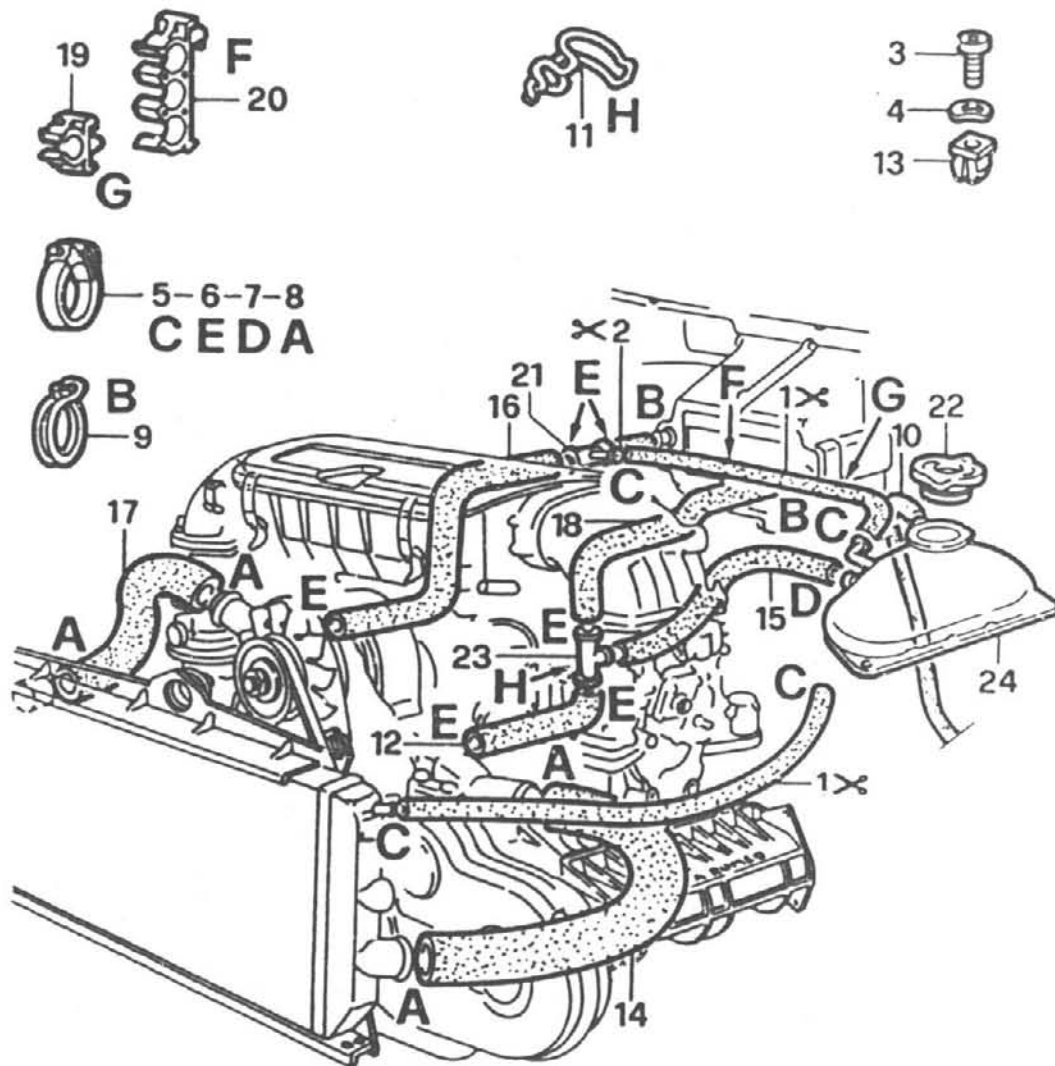

| pos. | TEILNUMMER | ref. | mg. benennung |
|------|-------------------|------|-------------------|
| 1 | 00670 99980 | | ROHR |
| 2 | 00670 99733 | | ROHR |
| 3 | 02100 16340 00 00 | | 3 SCHRAUBE |
| 4 | 00126 01079 | | 3 SCHEIBE |
| 5 | 00131 00390 | | 3 SCHLAUCHBINDER |
| 6 | 00607 07717 | | 7 SCHLAUCHBINDER |
| 7 | 00131 01390 | | 2 SCHLAUCHBINDER |
| 8 | 00131 01990 | | 4 SCHLAUCHBINDER |
| 9 | 00605 02970 | | 2 SCHLAUCHBINDER |
| 10 | 00605 02973 | | 1 ROHR |
| 11 | 00605 15656 | | 1 SCHELLE |
| 12 | 00605 02989 | | 1 ROHR |
| 13 | 00607 13740 | | 3 ZWISCHENSTUECK |
| 14 | 00605 03117 | | 1 ROHR |
| 15 | 00605 06764 | | 1 ROHR |
| 16 | 00605 06766 | | 1 ROHR |
| 17 | 00605 17641 | | 1 ROHR |
| 18 | 00605 06768 | | 1 ROHR |
| 19 | 00605 17708 | | 1 ROHRBEFESTIGUNG |
| 20 | 00605 03175 | | 1 ROHRBEFESTIGUNG |
| 21 | 00605 04195 | | 1 VERTEILER |
| 22 | 00605 04215 | | 1 STOPFEN |
| 23 | 00605 06769 | | 1 VERTEILER |
| 24 | 00605 04309 | | 1 BEHAELTER |

J₉

SPRINT
Ed. 87
Meccanica

1-1989

I.E.

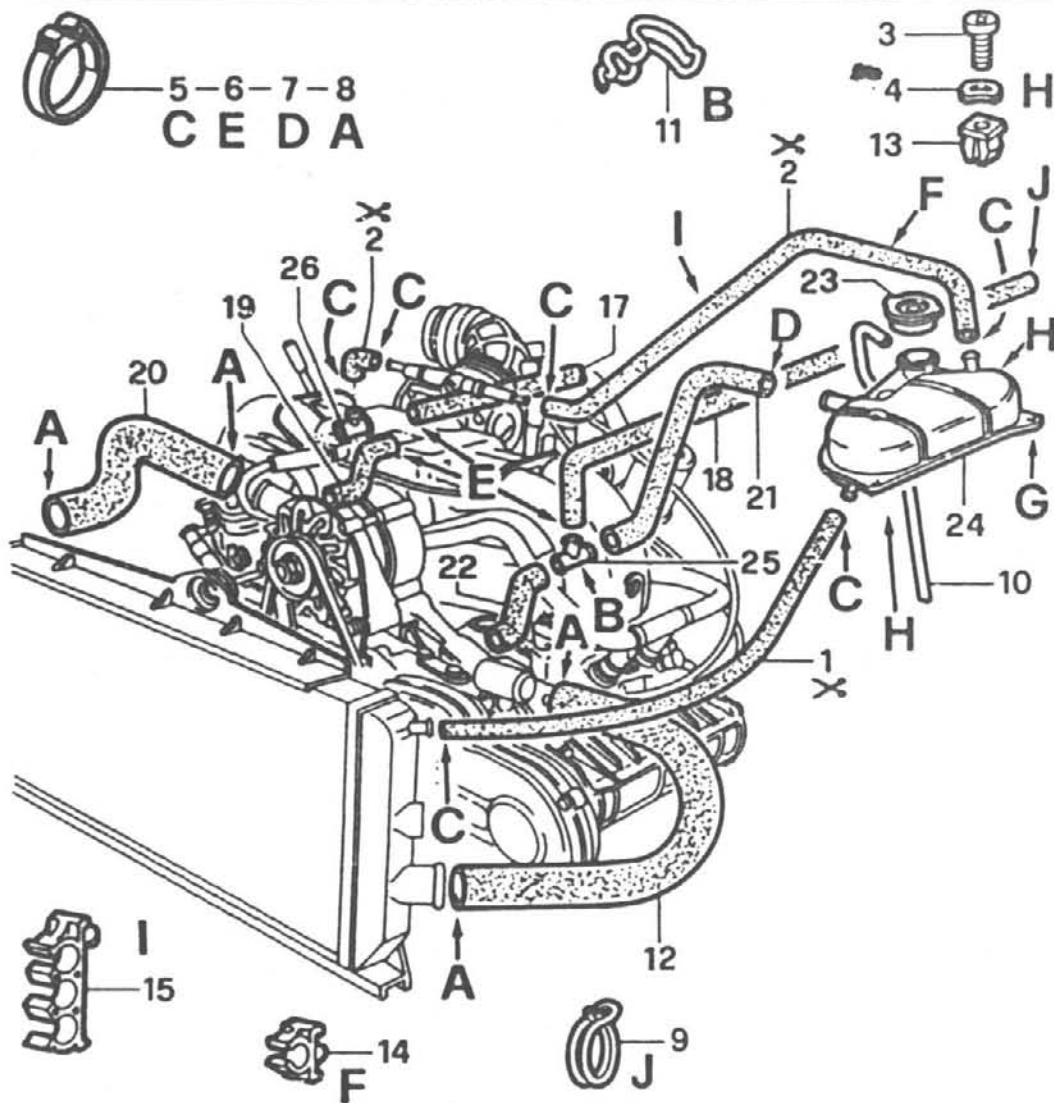

TAV. 04.11/5

c.c. 32



| pos. | TEILNUMMER | ref. | mg. benennung |
|------|-------------------|------|-------------------|
| 1 | 00670 99980 | | ROHR |
| 2 | 00670 99962 | | ROHR |
| 3 | 02100 16340 00 00 | | 3 SCHRAUBE |
| 4 | 00126 01079 | | 3 SCHEIBE |
| 5 | 00131 00390 | | 3 SCHLAUCHBINDER |
| 6 | 00607 07717 | | 7 SCHLAUCHBINDER |
| 7 | 00131 01390 | | 1 SCHLAUCHBINDER |
| 8 | 00131 01990 | | 4 SCHLAUCHBINDER |
| 9 | 00605 02970 | | 2 SCHLAUCHBINDER |
| 10 | 00605 02973 | | 1 ROHR |
| 11 | 00605 15656 | | 1 SCHELLE |
| 12 | 00605 03117 | | 1 ROHR |
| 13 | 00607 13740 | | 3 ZWISCHENSTUECK |
| 14 | 00605 17708 | | 1 ROHRBEFESTIGUNG |
| 15 | 00605 03175 | | 1 ROHRBEFESTIGUNG |
| 17 | 00605 24146 | | 1 ROEHRCHEN |
| 18 | 00605 25133 | | 1 ROHR |
| 19 | 00605 25134 | | 1 ROHR |
| 20 | 00605 25136 | | 1 ROHR |
| 21 | 00605 25137 | | 1 ROHR |
| 22 | 00605 25138 | | 1 ROHR |
| 23 | 00605 04215 | | 1 STOPFEN |
| 24 | 00605 36104 | | 1 BEHAELTER |
| 25 | 00605 06769 | | 1 VERTEILER |
| 26 | 00605 38060 | | 1 VERTEILER |

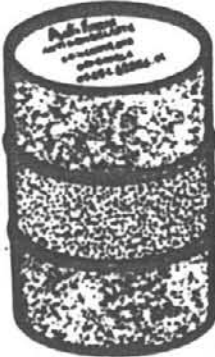

- . TABELLA CONFEZIONI ANTIGELO
- . ANTIFREEZE PACKINGS TABLE
- . TABLE DES CONGECIONS D'ANTIGEL
- . VERPACKUNGSTABELLE FÜR KÜHLERFROSTSCHUTZ
- . PROSPECTO DE LAS CONFECCIONES DEL ANTICONGELANTE

| ANTIGELO CONCENTRATO *CONCENTRATED ANTIFREEZE * ANTIGEL CONCENTRE * KONZERTRIERTER KÜHLERFROSTSCHUTZ * ANTICONGELANTE CONCENTRADO | | | | | | | | | | | | | | |
|---|--|---|------------|---|-------------------------------------|---|--------|--------|---|--------|--|--------|---|---|
|  | | ANTIFREEZE | | Circuito di Raffreddamento Circuit de Refroidissement Cooling Circuit Kühlkreislauf | | ALFA 33 ALFA SUD (TUTTE) ARNA | | | ALFA 33 TURBO DIESEL | | | | | |
| | | FLACONE LT 1 BOTTLE LT 1 FLACON LT 1 FLASCHE LT 1 FRASCO LT 1 | 0066280751 | Capacità del Circuito Capacité du Circuit Capacity of Circuit Füllen des Kühlkreislaufes | Litri Litres Liters Liters | 7,3 | | | 5,3 | | | | | |
| | | | | Temperatura Minima Temperatura Minimum Minimum Temperature Mindesttemperatur | | - 10°C | - 20°C | - 35°C | - 10°C | - 20°C | - 35°C | | | |
| | | | | Anticongelante Concentrato Antigel Concentré Concentrated Antifreeze Konzentrierter Kühlerfrostschutz | | Litri Litres Liters Liters | 1,9 | 2,6 | 3,7 | 1,3 | 1,9 | 2,7 | | |
| | | | | Acqua Distillata o Potabile Eau Potable ou Distillée Soft or Distilled Water Trink Oder Destilliertes Wasser | | Litri Litres Liters Liters | 5,4 | 4,7 | 3,6 | 4,0 | 3,4 | 2,6 | | |
|  | | ANTIFREEZE | | Circuito di Raffreddamento Circuit de Refroidissement Cooling Circuit Kühlkreislauf | | ALFA 6 2.0 - 2.5 ALFA 90 6 CIL. 2.0 - 2.5 ALFA 75 2.5 MILANO 2.5 - 3.0 164 3.0 | | | ALFETTE GIULIETTE ALFA 90 1.8 - 2.0 ALFA 75 1.6-1.8-2.0-1.8 T.B. 164 2.0 | | 2.0 BERLINA 2.0 GT VEL. 2.0 SPIDER VEL. | | VETTURE TURBO DIESEL (TUTTE) | |
| | | CUBO LT 20 CANISTER LT 20 JERRYCAN LT 20 KANISTER LT 20 BARRICA LT 20 | 0066280752 | Capacità del Circuito Capacité du Circuit Capacity of Circuit Füllen des Kühlkreislaufes | Litri Litres Liters Liters | 13 | | | 8 | | 9,7 | | 10 | |
| | | | | Temperatura Minima Temperatura Minimum Minimum Temperature Mindesttemperatur | | - 20°C | - 35°C | - 20°C | - 35°C | - 20°C | - 35°C | - 20°C | - 35°C | |
| | | | | Anticongelante Concentrato Antigel Concentré Concentrated Antifreeze Konzentrierter Kühlerfrostschutz | | Litri Litres Liters Liters | 4,6 | 6,5 | 3 | 4 | 3,4 | 4,9 | 3,5 | 5 |
| | | | | Acqua Distillata o Potabile Eau Potable ou Distillée Soft or Distilled Water Trink Oder Destilliertes Wasser | | Litri Litres Liters Liters | 8,4 | 6,5 | 5 | 4 | 6,3 | 4,8 | 6,5 | 5 |
|  | | ANTIFREEZE | | Circuito di Raffreddamento Circuit de Refroidissement Cooling Circuit Kühlkreislauf | | ALFA 6 2.0 - 2.5 ALFA 90 6 CIL. 2.0 - 2.5 ALFA 75 2.5 MILANO 2.5 - 3.0 164 3.0 | | | ALFETTE GIULIETTE ALFA 90 1.8 - 2.0 ALFA 75 1.6-1.8-2.0-1.8 T.B. 164 2.0 | | 2.0 BERLINA 2.0 GT VEL. 2.0 SPIDER VEL. | | VETTURE TURBO DIESEL (TUTTE) | |
| | | FUSTO LT 200 DRUM LT 200 FUT LT 200 FASS LT 200 BARRIL LT 200 | 0066280753 | Capacità del Circuito Capacité du Circuit Capacity of Circuit Füllen des Kühlkreislaufes | Litri Litres Liters Liters | 13 | | | 8 | | 9,7 | | 10 | |
| | | | | Temperatura Minima Temperatura Minimum Minimum Temperature Mindesttemperatur | | - 20°C | - 35°C | - 20°C | - 35°C | - 20°C | - 35°C | - 20°C | - 35°C | |
| | | | | Anticongelante Concentrato Antigel Concentré Concentrated Antifreeze Konzentrierter Kühlerfrostschutz | | Litri Litres Liters Liters | 4,6 | 6,5 | 3 | 4 | 3,4 | 4,9 | 3,5 | 5 |
| | | | | Acqua Distillata o Potabile Eau Potable ou Distillée Soft or Distilled Water Trink Oder Destilliertes Wasser | | Litri Litres Liters Liters | 8,4 | 6,5 | 5 | 4 | 6,3 | 4,8 | 6,5 | 5 |

J13

- . TABELLA CONFEZIONI ANTIGELO
- . ANTIFREEZE PACKINGS TABLE
- . TABLE DES CONGECIONS D'ANTIGEL
- . VERPACKUNGSTABELLE FÜR KÜHLERFROSTSCHUTZ
- . PROSPECTO DE LAS CONFECCIONES DEL ANTICONGELANTE

ANTIGELO CONCENTRATO * CONCENTRATED ANTIFREEZE * ANTIGEL CONCENTRE * KONZENTRIERTER KÜHLERFROSTSCHUTZ * ANTICONGELANTE CONCENTRADO

| ANTIFREEZE | | Circuito di Raffreddamento Circuit de Refroidissement Cooling Circuit Kühlkreislauf | | GTV 6 2,5 | | F. 12 AR 6 | | AR. 8 | |
|---|---|---|-------------------------------------|-------------------------------------|--------|---------------|--------|--------|--------|
|  | FLACONE LT 1 BOTTLE LT 1 FLACON LT 1 FLASCHE LT 1 FRASCO LT 1 | Capacità del Circuito Capacité du Circuit Capacity of Circuit Füllen des Kühlkreislaufes | Litri Litres Liters Liters | 12 | | 9 | | 11 | |
| | 0066280751 | Temperatura Minima Temperatura Minimum Minimum Temperature Mindesttemperatur | | - 20°C | - 35°C | - 20°C | - 35°C | - 20°C | - 35°C |
|  | CUBO LT 20 CANISTER LT 20 JERRYCAN LT 20 KANISTER LT 20 BARRICA LT 20 | Anticongelante Concentrato Antigel Concentré Concentrated Antifreeze Konzentrierter Kühlerfrostschutz | Litri Litres Liters Liters | 4,2 | 6,0 | 3,2 | 4,5 | 3,9 | 5,5 |
| | 0066280752 | Acqua Distillata o Potabile Eau Potable ou Distillée Soft or Distilled Water Trink Oder Destilliertes Wasser | Litri Litres Liters Liters | 7,8 | 6,0 | 5,8 | 4,5 | 7,1 | 5,5 |
|  | FUSTO LT 200 DRUM LT 200 FUT LT 200 FA3S LT 200 BARRIL LT 200 | Circuito di Raffreddamento Circuit de Refroidissement Cooling Circuit Kühlkreislauf | | GIULIA 1.3-1.6 BERLINA SPIDER | | GIULIA DIESEL | | | |
| | 0066280753 | Capacità del Circuito Capacité du Circuit Capacity of Circuit Füllen des Kühlkreislaufes | Litri Litres Liters Liters | 7,5 | | 7,1 | | | |
| | | Temperatura Minima Temperatura Minimum Minimum Temperature Mindesttemperatur | | - 20°C | - 35°C | - 20°C | - 35°C | | |
| | | Anticongelante Concentrato Antigel Concentré Concentrated Antifreeze Konzentrierter Kühlerfrostschutz | Litri Litres Liters Liters | 2,6 | 3,8 | 2,5 | 3,6 | | |
| | | Acqua Distillata o Potabile Eau Potable ou Distillée Soft or Distilled Water Trink Oder Destilliertes Wasser | Litri Litres Liters Liters | 4,9 | 3,7 | 4,6 | 3,5 | | |

J14

- TABELLA CONFEZIONI ANTIGELO
- ANTIFREEZE PACKINGS TABLE
- TABLE DES CONGECIONS D'ANTIGEL
- VERPACKUNGSTABELLE FÜR KÜHLERFROSTSCHUTZ
- PROSPECTO DE LAS CONFECCIONES DEL ANTICONGELANTE

LIQUIDO PERMANENTE - 20° C ★ PERMANENT LIQUID - 20° C ★ LIQUID PERMANENT - 20° C ★ PERMANENTE FLUSSIGKEIT - 20° C ★ LIQUIDO PERMANENTE - 20° C

CLIMA FLUID Permanent -20



| | |
|---------|------|
| FLACONE | LT 1 |
| BOTTLE | LT 1 |
| FLACON | LT 1 |
| FLASCHE | LT 1 |
| FRASCO | LT 1 |

0066280758

CAPACITA' DEI CIRCUITI DI RAFFREDDAMENTO CAPACITE DES CIRCUITS DE REFROIDISSEMENT COOLING SYSTEM CAPACITY FÜLLEN DES KÜHLKREISLAUF

| MODELLO VETTURA MODELE DE VOITURE CAR MODEL AUTO MODELL | ALFA 33 ALFASUD (TUTTE) ARNA | ALFA 33 TURBO DIESEL | | | |
|--|---------------------------------------|--|---------------------------------------|---|--|
| CAPACITA' LITRI CATACTE LITRI CAPACITY LITERS FÜLLEN LITERS | 7,3 | 5,3 | | | |
| MODELLO VETTURA MODELE DE VOITURE CAR MODEL AUTO MODELL | 1750 2000 | ALFETTE GIULIETTE ALFA 90 1.8 - 2.0 ALFA 75 1.6 - 1.8 - 2.0 - 1.8 T.B. | VETTURE TURBO DIESEL (TUTTE) | ALFA 6 2.0 - 2.5 ALFA 90 6 CIL. 2.0 - 2.5 ALFA 75 2.5 MILANO 2.5 - 3.0 164 3.0 | |
| CAPACITA' LITRI CATACTE LITRI CAPACITY LITERS FÜLLEN LITERS | 9,7 | 8 | 10 | 13 | |
| MODELLO VETTURA MODELE DE VOITURE CAR MODEL AUTO MODELL | GTV 6 2.5 | A.R. 8 | F. 12 AR 6 | GIULIA DIESEL | GIULIA 1.3 - 1.6 BERLINA - GT - SPIDER |
| CAPACITA' LITRI CATACTE LITRI CAPACITY LITERS FÜLLEN LITERS | 12 | 11 | 9 | 7,1 | 7,5 |



| | |
|----------|-------|
| CUBO | LT 20 |
| CANISTER | LT 20 |
| JERRYCAN | LT 20 |
| KANISTER | LT 20 |
| BARRICA | LT 20 |

0066280759

K

1

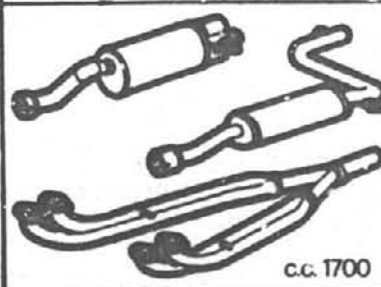

2

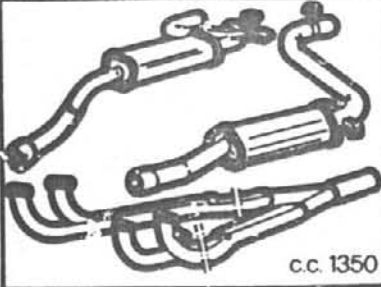

3

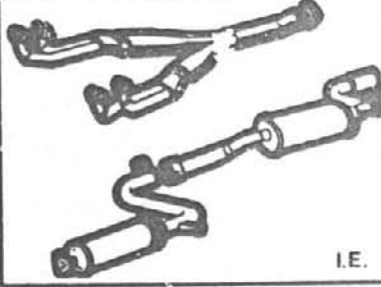

4

5

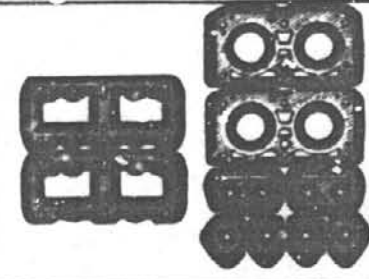

6

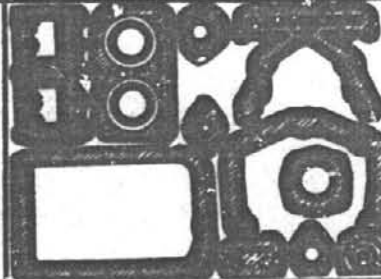

7

8

9

10

11

12

13

14

15

16

17

18

19

K₁

SPRINT
Ed. 87
Meccanica

1-1999

c.c. 1.7

TAV. 02.64/1

c.c. 32

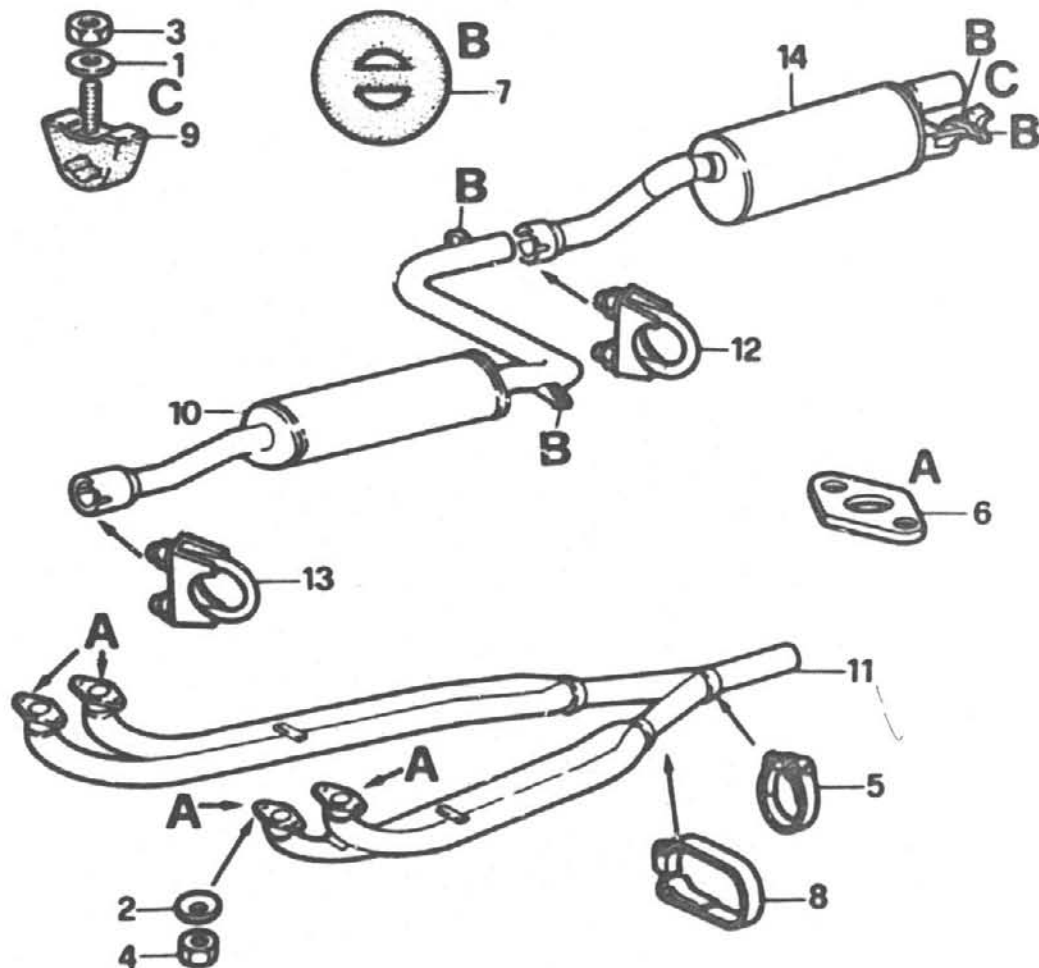

| pos. | TEILNUMMER | ref. | mg. benennung |
|------|-------------------|------|------------------|
| 1 | 02100 81408 00 00 | | 1 SCHEIBE |
| 2 | 02100 81434 00 00 | | 8 SCHEIBE |
| 3 | 00156 96211 | | 1 MUTTER |
| 4 | 00161 00311 | | 8 MUTTER |
| 5 | 00131 02190 | | 1 SCHELLE |
| 6 | 00605 02984 | | 4 DICHTUNG |
| 7 | 00605 03033 | | 4 SPRENGRING |
| 8 | 00605 05562 | | 2 SCHELLE |
| 9 | 00605 04209 | | 1 ZWISCHENSTUECK |
| 10 | 00605 37136 | | 1 AUSPUFFTOPF |
| 11 | 00605 37453 | | 1 AUSPUFFROHR |
| 12 | 00605 04378 | | 1 KLEMME |
| 13 | 00605 04379 | | 1 KLEMME |
| 14 | 54839 00000 00 01 | | 1 AUSPUFFTOPF |

K₂

SPRINT
Ed. 87
Meccanica

1-1989

c.c. 1.3

TAV. 02.84

c.c. 32

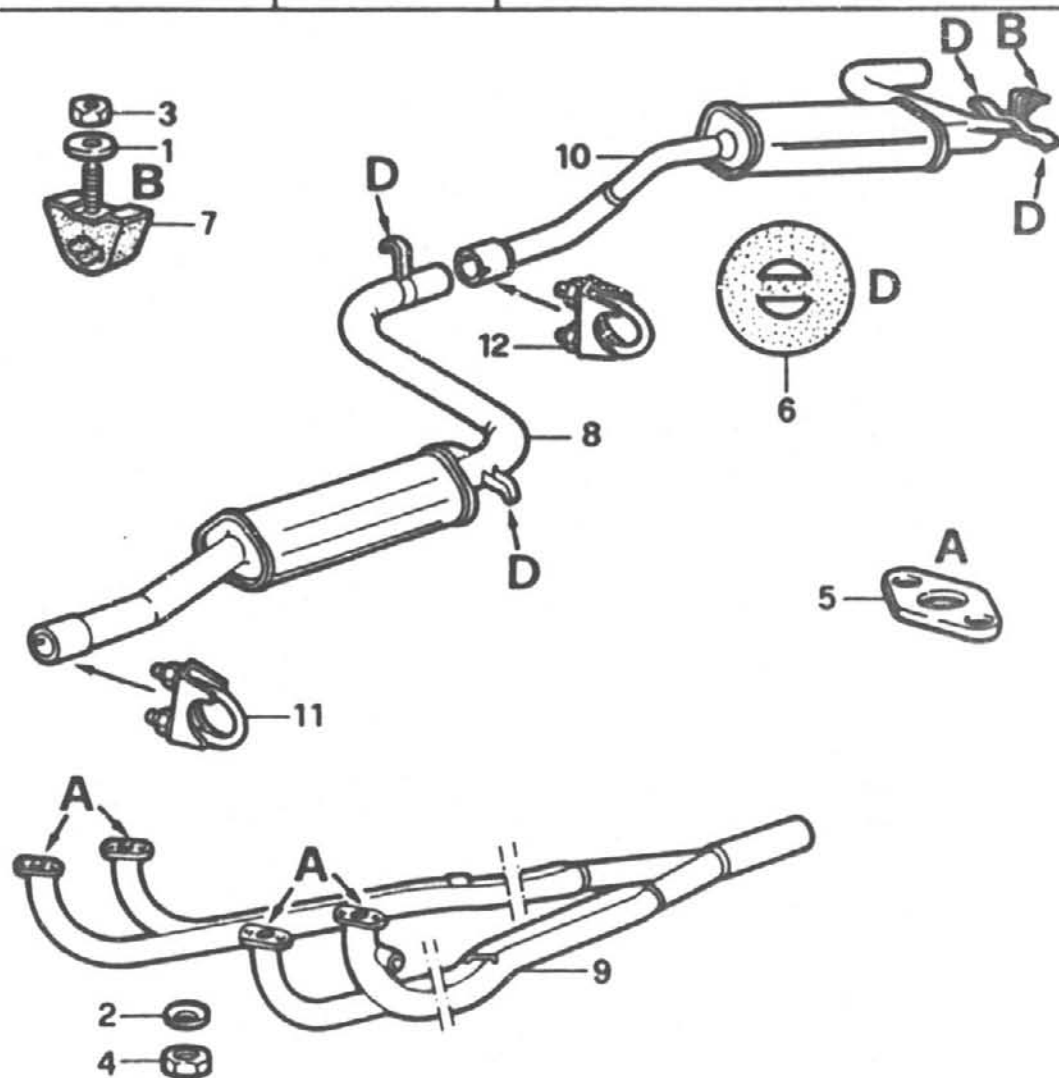

| pos. | TEILNUMMER | ref. | mg. | benennung |
|------|-------------------|------|-----|----------------|
| 1 | 02100 81408 00 00 | | 1 | SCHEIBE |
| 2 | 02100 81434 00 00 | | 8 | SCHEIBE |
| 3 | 00158 96211 | | 1 | MUTTER |
| 4 | 00161 00811 | | 8 | MUTTER |
| 5 | 00605 02984 | | 4 | DICHTUNG |
| 6 | 00605 03033 | | 4 | SPRENGRING |
| 7 | 00605 04209 | | 1 | ZWISCHENSTUECK |
| 8 | 00605 04299 | | 1 | AUSPUFFTOPF |
| 9 | 00605 04302 | | 1 | AUSPUFFROHR |
| 10 | 00605 04365 | | 1 | AUSPUFFTOPF |
| 11 | 00605 04378 | | 1 | KLEMME |
| 12 | 00605 04379 | | 1 | KLEMME |

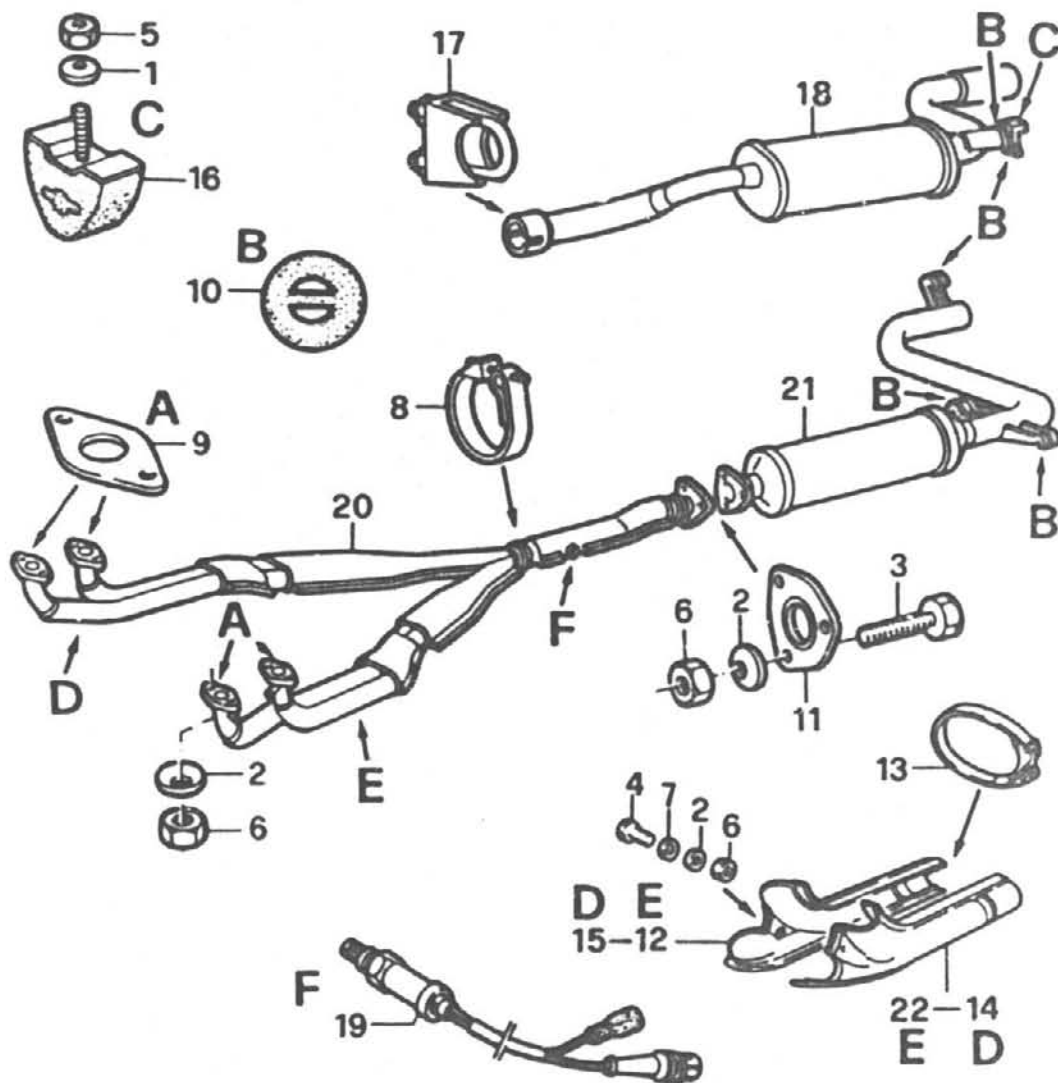

| pos. | TEILNUMMER | ref. | mg. benennung |
|------|-------------------|------|------------------|
| 1 | 02100 81408 00 00 | | 1 SCHEIBE |
| 2 | 02100 81434 00 00 | | 7 SCHEIBE |
| 3 | 021G5 02008 00 00 | | 1 SCHRAUBE |
| 4 | 00160 44621 | | 3 SCHRAUBE |
| 5 | 00158 96211 | | 1 MUTTER |
| 6 | 00161 00811 | | 7 MUTTER |
| 7 | 00107 32211 | | 1 WIDERSTAND |
| 8 | 00131 02190 | | 1 SCHELLE |
| 9 | 00605 02984 | | 4 DICHTUNG |
| 10 | 00605 03033 | | 4 RING |
| 11 | 00605 17483 | | 1 DICHTUNG |
| 12 | 00605 23722 | | 1 GEHAUSEHAELFTE |
| 13 | 00605 06562 | | 2 SCHELLE |
| 14 | 00605 24145 | | 1 GEHAUSEHAELFTE |
| 15 | 00605 24146 | | 1 GEHAUSEHAELFTE |
| 16 | 00605 04209 | | 1 GUMMITEIL |
| 17 | 00605 04378 | | 1 KLEMME |
| 18 | 00605 37532 | | 1 AUSPUFFTOPF |
| 19 | 00605 37650 | | 1 LAMBDA SONDE |
| 20 | 00605 37816 | | 1 AUSPUFFTOPF |
| 21 | 00605 37817 | | 1 AUSPUFFTOPF |
| 22 | 00605 37941 | | 1 GEHAUSEHAELFTE |

K₅

SPRINT
Ed. 87
Meccanica

1-1989

TAV. 01.90

c.c. 32

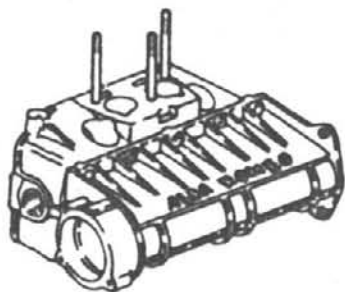

2
1

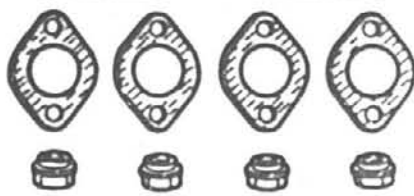
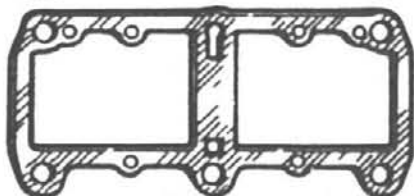
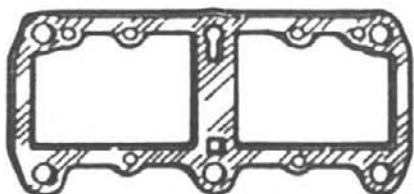
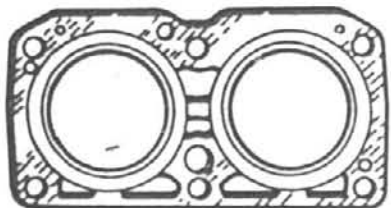
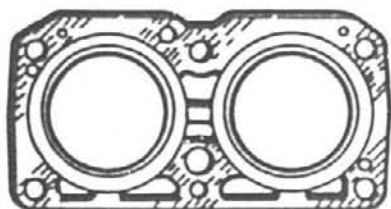

| pos. | TEILNUMMER | ref. | mg. benennung |
|------|-------------|------|-----------------|
| 1 | 00607 50652 | ▲ | 1 REPARATURSATZ |
| 2 | 00607 50825 | ● | 1 REPARATURSATZ |

▲ c.c. 1.3

● c.c. 1.7

K₆

SPRINT
Ed. 87
Meccanica
1-1989

TAV. 09.00

c.c. 32

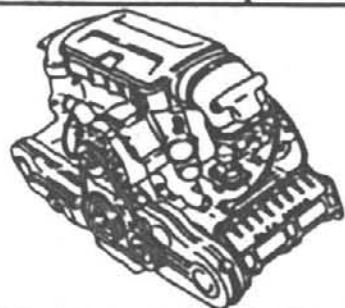



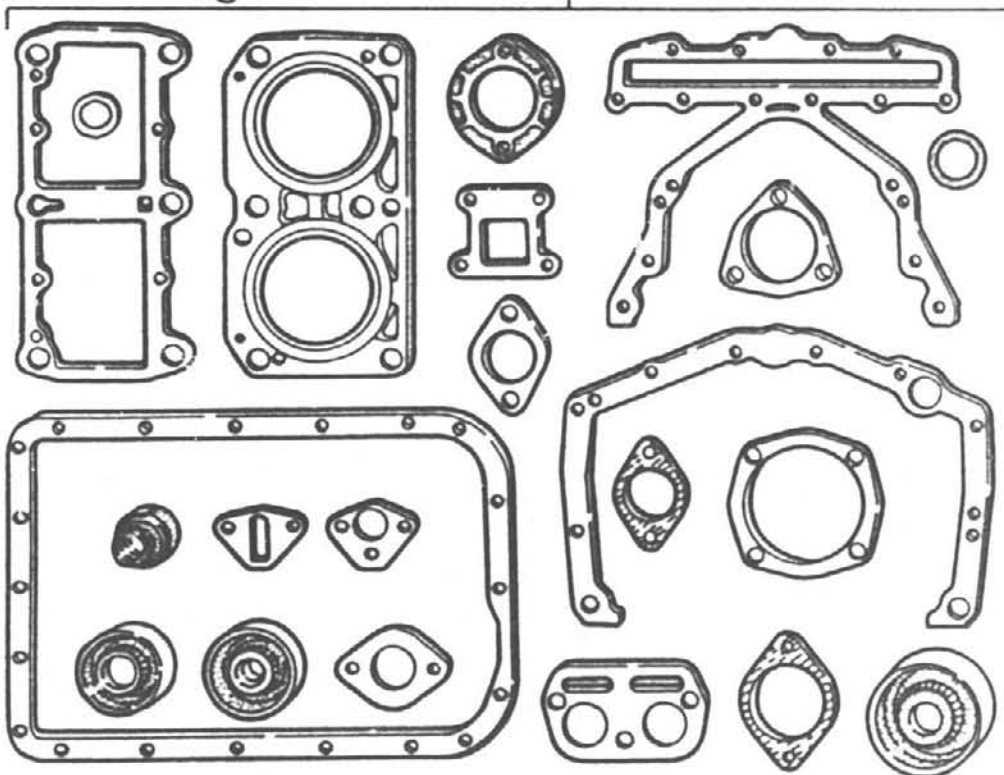

2
1

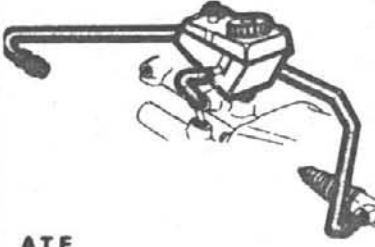
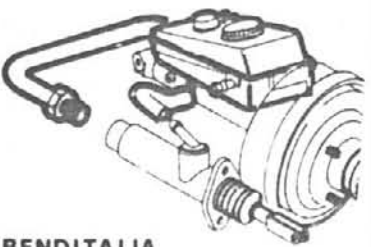

| pos. | TEILNUMMER | ref. | mg. | benennung |
|------|-------------|------|-----|--------------------|
| 1 | 00607 50598 | ▲ | 1 | MOTORDICHTUNGSSATZ |
| 2 | 00607 50829 | ● | 1 | MOTORDICHTUNGSSATZ |

▲ c.c. 1.3
● c.c. 1.7

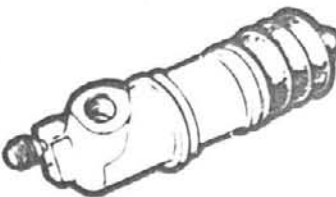
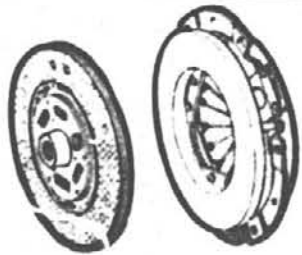
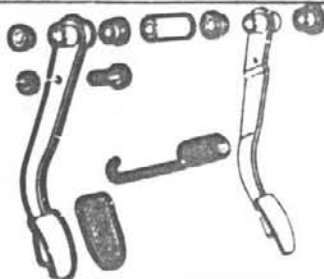
| | | | | | |
|---|--|--|---|--|---|
| SPRINT 87 MECCANICA | 9-1987 | 1 TAV 11.10 | 2 TAV 11.10/1 | 3 TAV | 4 TAV 11.20 |
| <div style="text-align: center; font-size: 48px; font-weight: bold;">L</div> |  ATE |  BENDITALIA | |  ATE | |
| 5 TAV 11.21 | 6 TAV | 7 TAV 11.30 | 8 TAV 11.31 | 9 TAV | |
|  BENDITALIA | |  ATE |  BENDITALIA | | |
| 10 TAV 11.50 | 11 TAV | 12 TAV | 13 TAV 21.85/1 | 14 TAV | |
|  | | |  | | |
| 15 TAV | 16 TAV | 17 TAV | 18 TAV | 19 TAV | |
| | | | | | |

L1

SPRINT
Ed. 87
Meccanica
1-1989

ATE

TAV. 11.10

c.c. 32

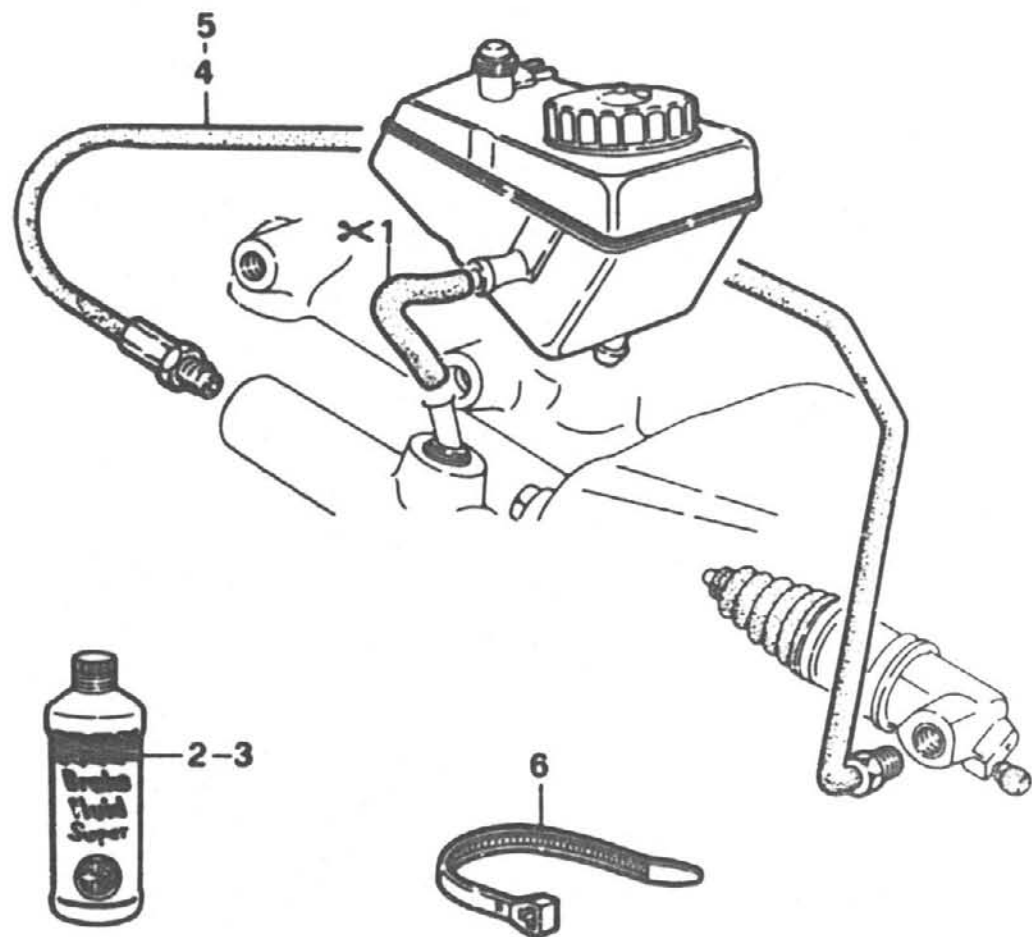

| pos. | TEILNUMMER | ref. | mg. | benennung |
|------|-------------------|-------------------------------------|-----|-----------------|
| 1 | 00670 99738 | | | ROHR |
| 2 | 00607 10303 | | | BREMSOEL LT.1 |
| 3 | 09607 10304 | | | BREMSOEL LT.0,5 |
| 4 | 00605 37407 | <input checked="" type="checkbox"/> | 1 | ROHR |
| 5 | 00607 48202 | <input type="checkbox"/> | 1 | ROHR |
| 6 | 12716 00000 00 00 | | 1 | SHELLE |

G.D.
 G.S.

L2**SPRINT**
Ed. 87
Meccanica

1-1989

BENDITALIA

TAV. 11.10/1

c.c. 32

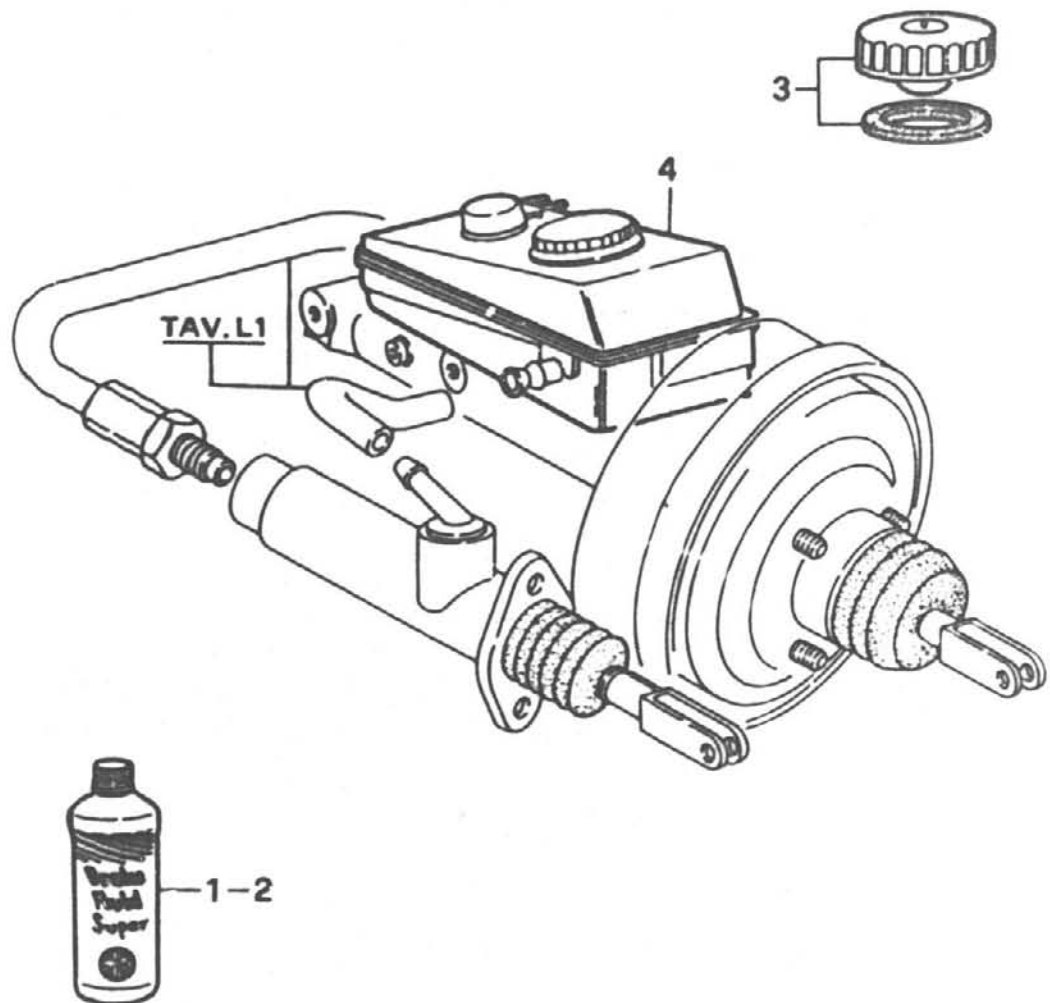

| pos. | TEILNUMMER | ref. | mg. benennung |
|------|-------------|------|----------------|
| 1 | 00607 10303 | | 1 BREMSOELLT.1 |
| 2 | 00607 10304 | | BREMSOELLT.0,5 |
| 3 | 00607 14536 | | 1 STOPFEN |
| 4 | 00607 49850 | | 1 BEHAELTER |

L4**SPRINT**
Ed. 87
Meccanica

1-1989

ATE

TAV. 11.20

c.c. 32

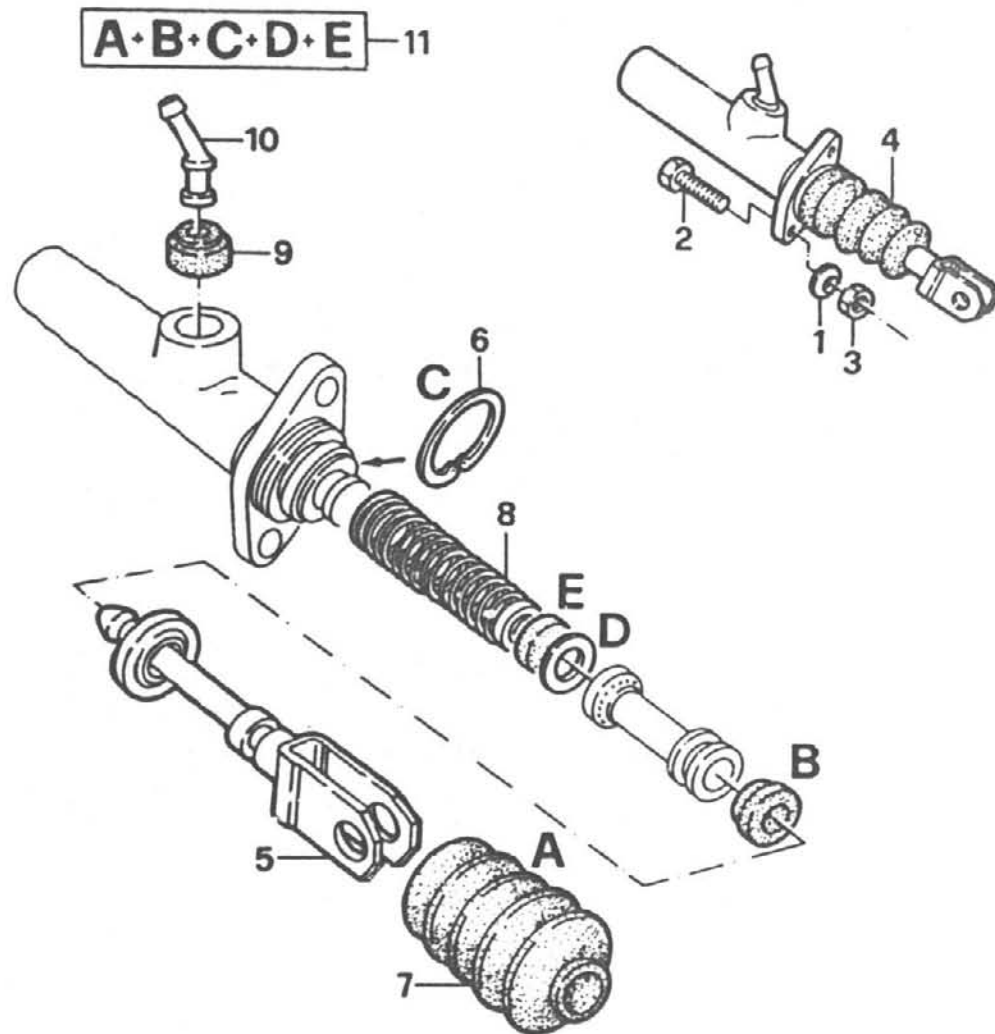

| pos. | TEILNUMMER | ref. | mg. benennung |
|------|-------------------|------|-----------------------|
| 1 | 02100 81434 00 00 | | 2 SCHEIBE |
| 2 | 00161 35721 | | 2 SCHRAUBE |
| 3 | 00161 00811 | | 2 MUTTER |
| 4 | 00605 01237 | | 1 KUPPLUNGBERZYLINDER |
| 5 | 00607 48269 | | 1 DRUCKSTANGE |
| 6 | 00607 48270 | | 1 SPRENGRING |
| 7 | 00607 48283 | | 1 MANSCHETTE |
| 8 | 00607 48284 | | 1 FEDER |
| 9 | 00607 48285 | | 1 DICHTUNG |
| 10 | 00607 48286 | | 1 BEFESTIGUNG |
| 11 | 00607 50513 | | 1 REPARATURSATZ |

L5

SPRINT
Ed. 87
Meccanica

1-1989

BENDITALIA

TAV. 11.21

c.c. 32

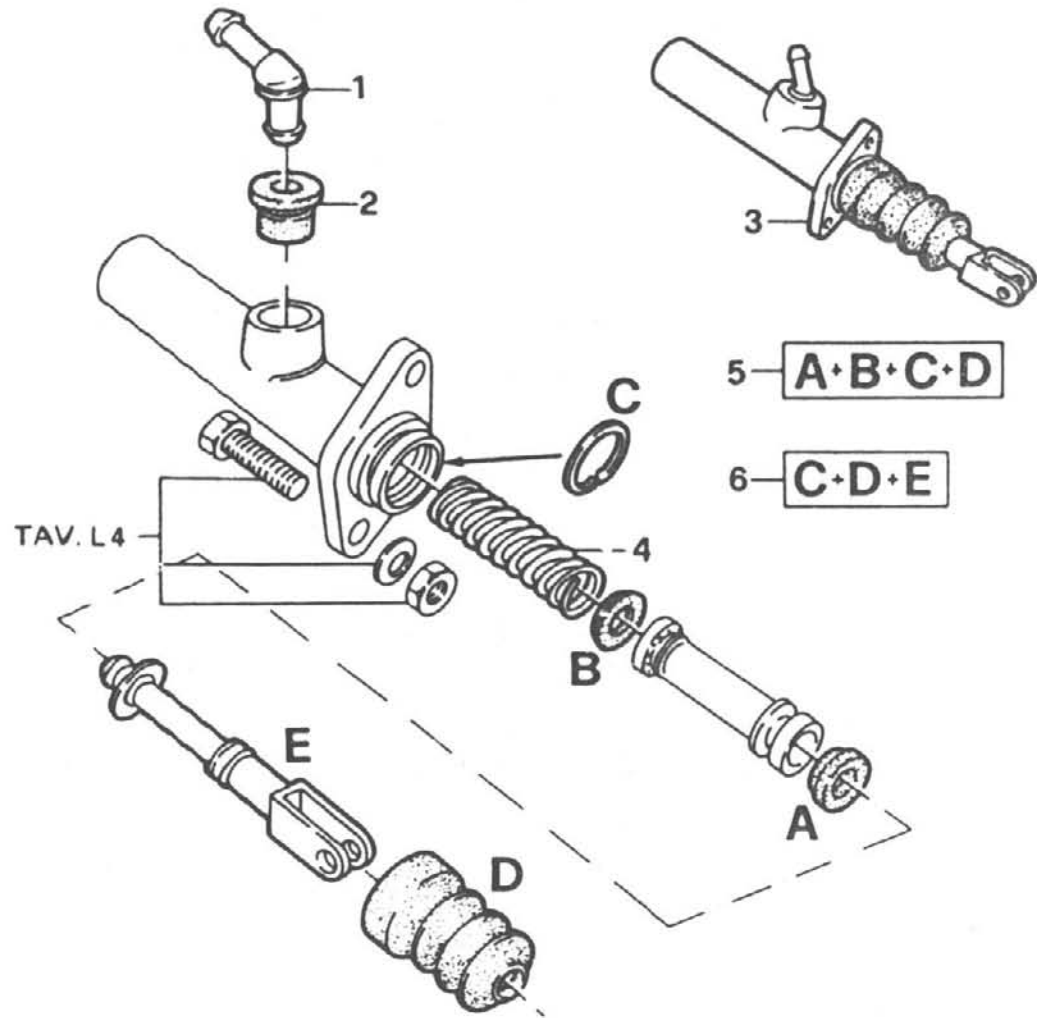

| pos. | TEILNUMMER | ref. | mg. benennung |
|------|-------------|------|----------------------|
| 1 | 00607 38588 | | 1 BEFESTIGUNG |
| 2 | 00607 38590 | | 1 GUMMITEIL |
| 3 | 00605 01237 | | 1 KUPPLUNGERZYLINDER |
| 4 | 00607 48358 | | 1 FEDER |
| 5 | 00607 50515 | | 1 REPARATURSATZ |
| 6 | 00607 50538 | | 1 REPARATURSATZ |

L7**SPRINT**
Ed. 87
Meccanica
1-1989**ATE**

TAV. 11.30

c.c. 32

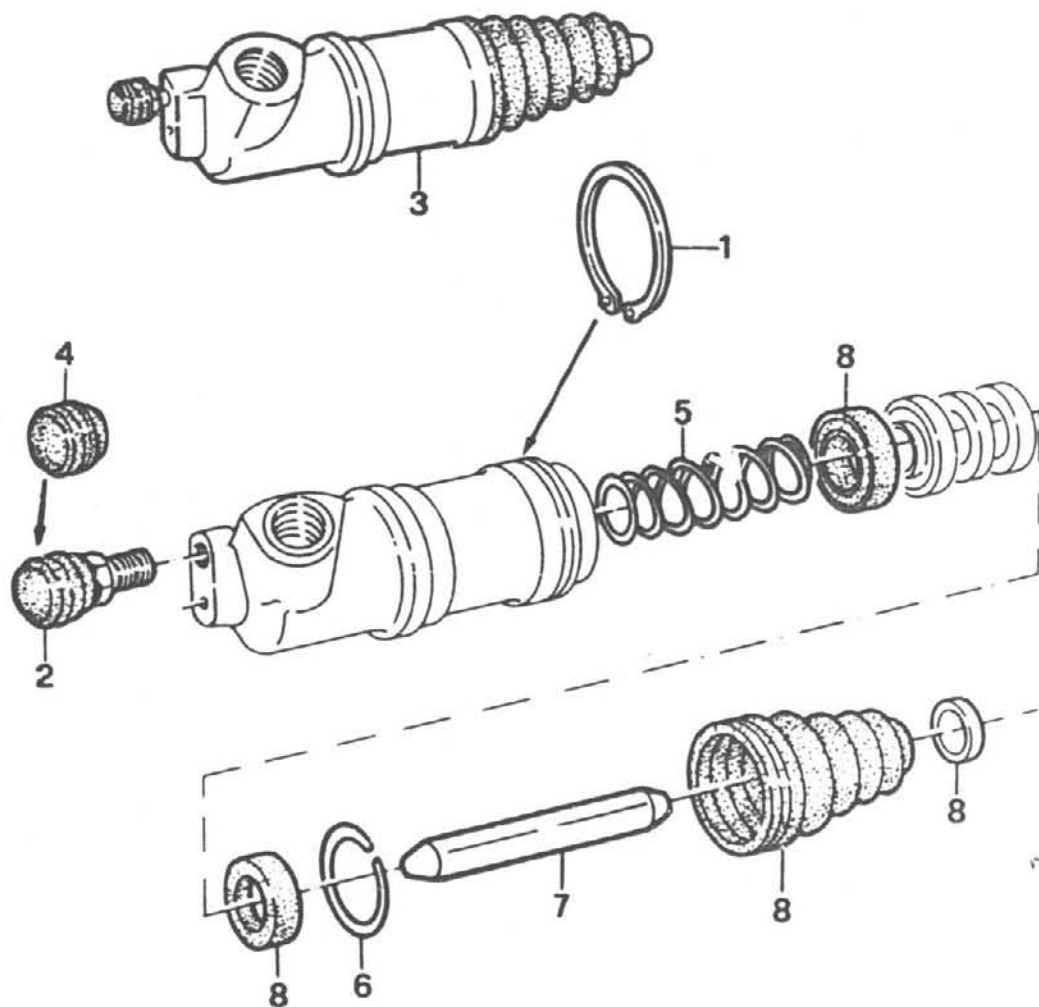

| pos. | TEILNUMMER | ref. | mg. benennung |
|------|-------------|------|-----------------|
| 1 | 00605 02660 | | 1 SPRENGRING |
| 2 | 00607 24243 | | 1 SCHRAUBE |
| 3 | 00605 02666 | | 1 ZYLINDER |
| 4 | 00607 48280 | | 1 KAPPE |
| 5 | 00607 48287 | | 1 FEDER |
| 6 | 00607 48288 | | 1 SPRENGRING |
| 7 | 00607 48289 | | 1 DRUCKSTANGE |
| 8 | 00607 50512 | | 1 REPARATURSATZ |

L8**SPRINT
Ed. 87
Meccanica**

1-1989

BENDITALIA

TAV. 11.31

c.c. 32

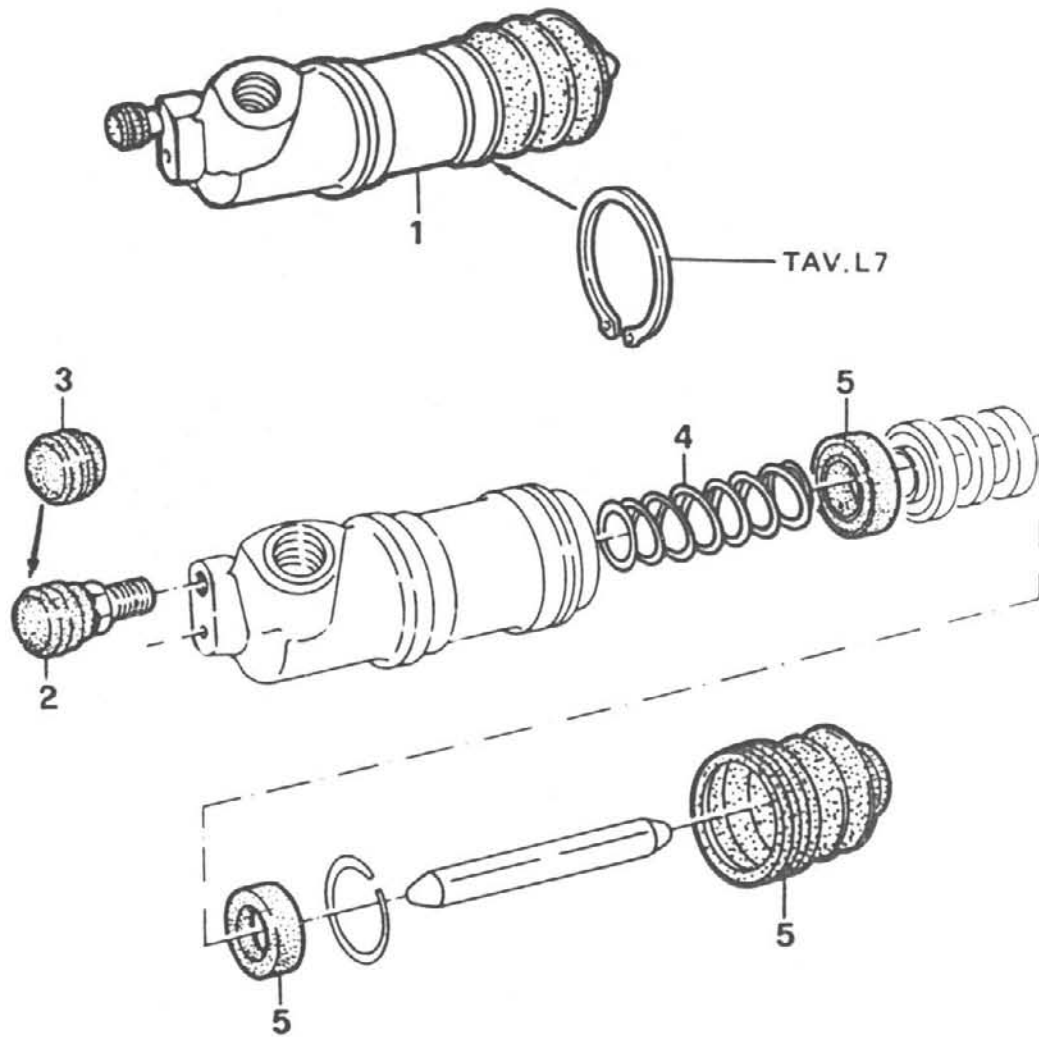

| pos. | TEILNUMMER | ref. | mg. benennung |
|------|-------------|------|-----------------|
| 1 | 00605 02666 | | 1 ZYLINDER |
| 2 | 00607 48353 | | 1 SCHRAUBE |
| 3 | 00607 48354 | | 1 KAPPE |
| 4 | 00607 48355 | | 1 FEDER |
| 5 | 00607 50514 | | 1 REPARATURSATZ |

L10

SPRINT
Ed. 87
Meccanica

1-1989

TAV. 11.50

c.c. 32

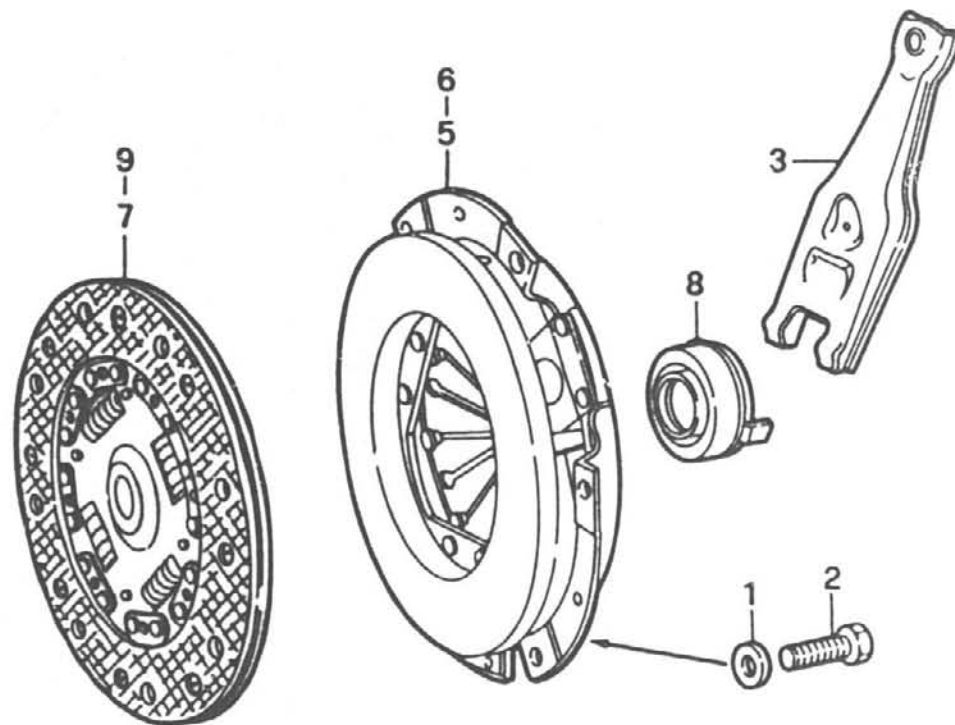

| pos. | TEILNUMMER | ref. | mg. | benennung |
|------|-------------------|------|-----|------------------|
| 1 | 02100 81434 00 00 | | 6 | SCHEIBE |
| 2 | 00160 43321 | | 6 | SCHRAUBE |
| 3 | 00605 02661 | | 1 | GABEL |
| 5 | 00605 04713 | ▲ | 1 | KUPPLUNGSKORB |
| 6 | 00605 14871 | ● | 1 | KUPPLUNGSKORB |
| 7 | 00605 36275 | | 1 | KUPPLUNGSSCHEIBE |
| 8 | 00605 02668 | | 1 | LAGER |
| 9 | 00605 38156 | ■ | 1 | KUPPLUNGSSCHEIBE |

▲ c.c. 1.3
● c.c. 1.7
■ I.E.

L13

SPRINT
Ed. 87
Meccanica

1-1989

TAV. 21.85/1

c.c. 32

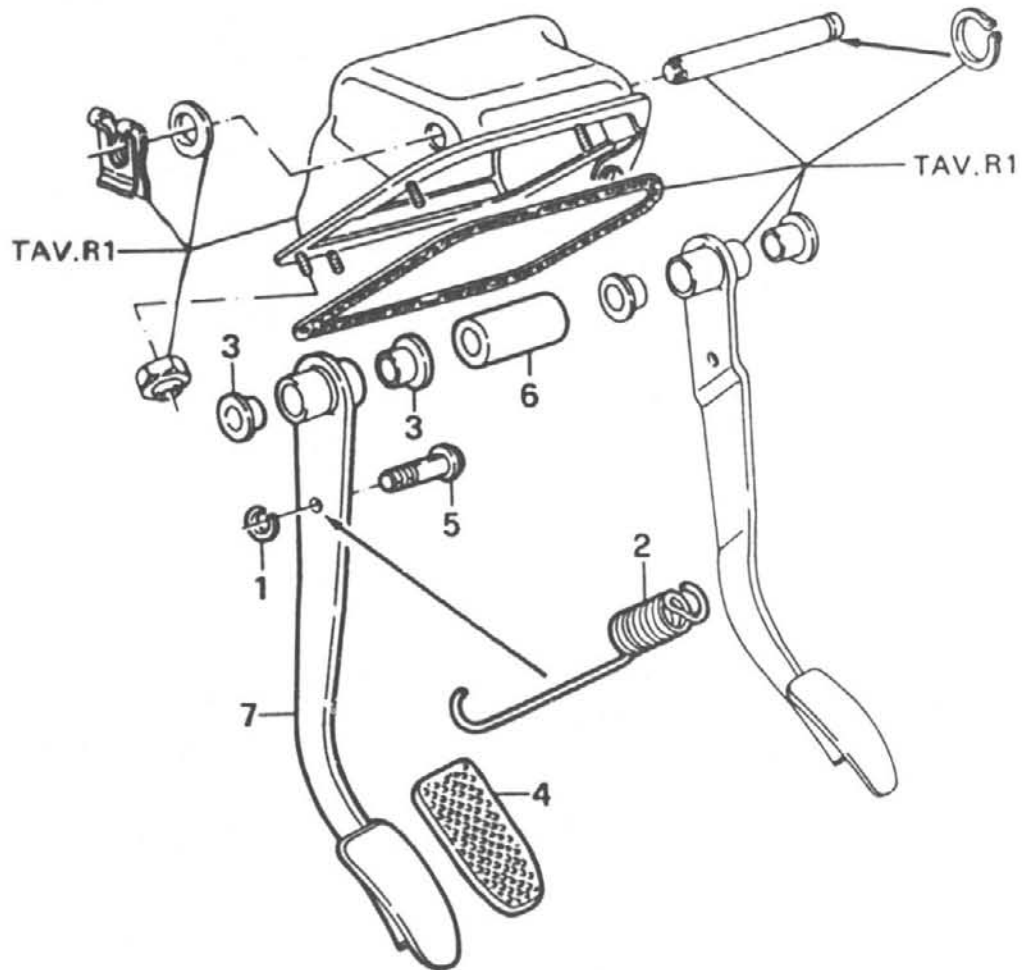

| pos. | TEILNUMMER | ref. | mg. benennung |
|------|-------------|------|------------------|
| 1 | 00110 65970 | | 1 RING |
| 2 | 00605 01328 | | 1 FEDER |
| 3 | 00605 01329 | | 2 BUECHSE |
| 4 | 00605 01331 | | 1 PEDALGÜMMI |
| 5 | 00605 01333 | | 1 BOLZEN |
| 6 | 00605 01675 | | 1 ABSTANDSTUECK |
| 7 | 00605 01686 | | 1 KUPPLUNGSPEDAL |

M

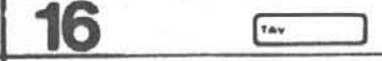
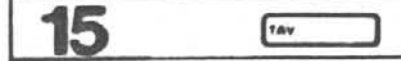
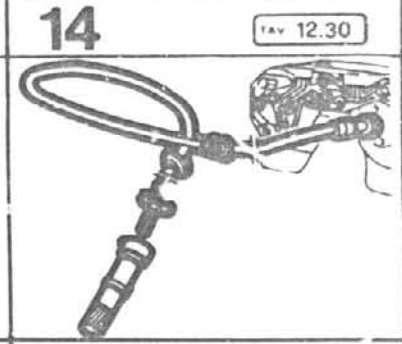
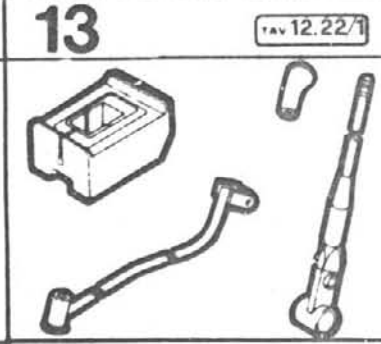
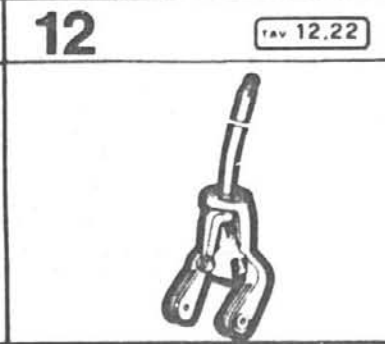
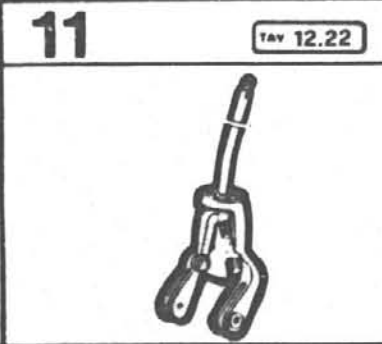
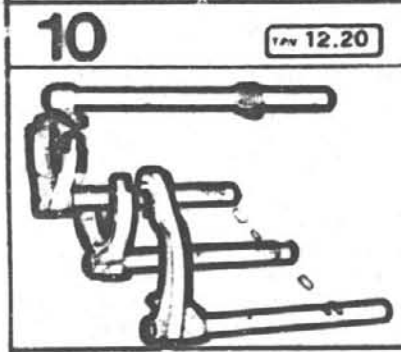
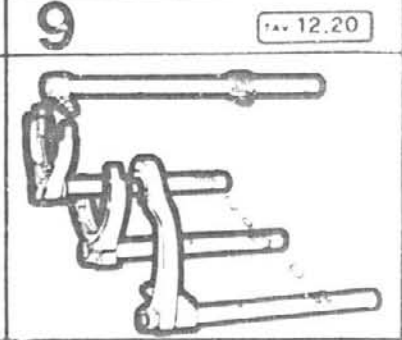
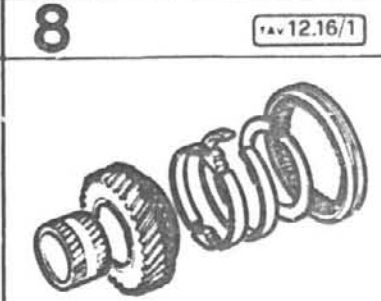
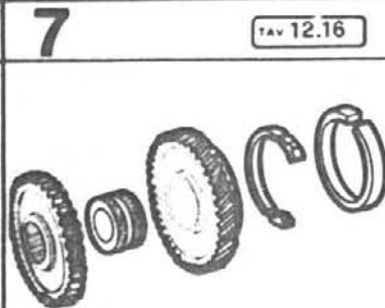
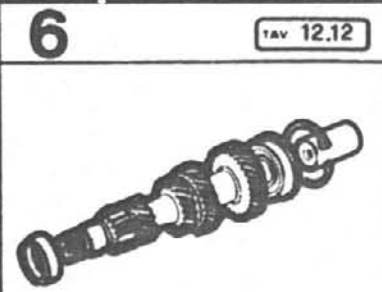
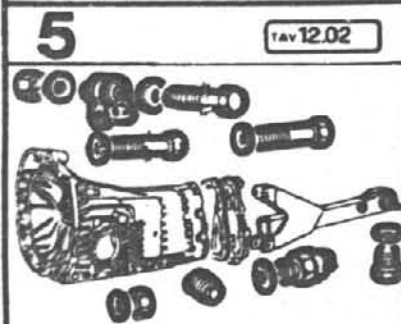
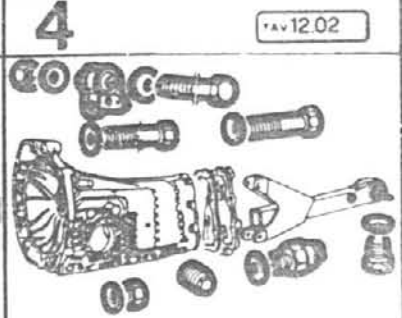
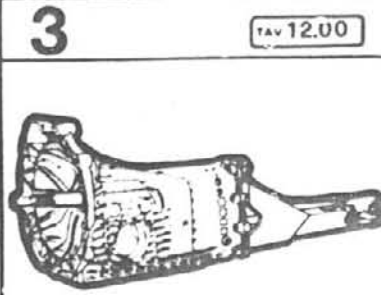
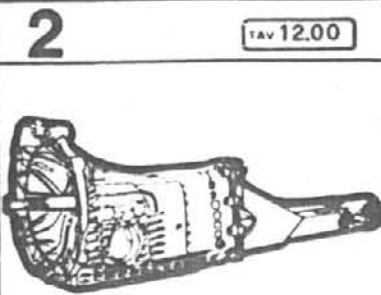
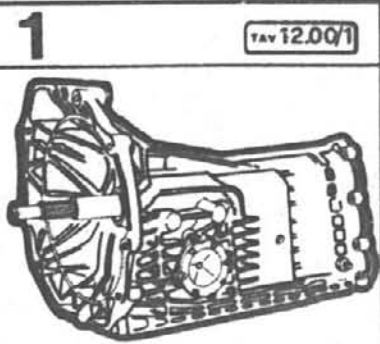

M₁

SPRINT
Meccanica
Ed. 87

1-1989

Erleichterte schaltung

TAV. 12.00/1

c.c. 32

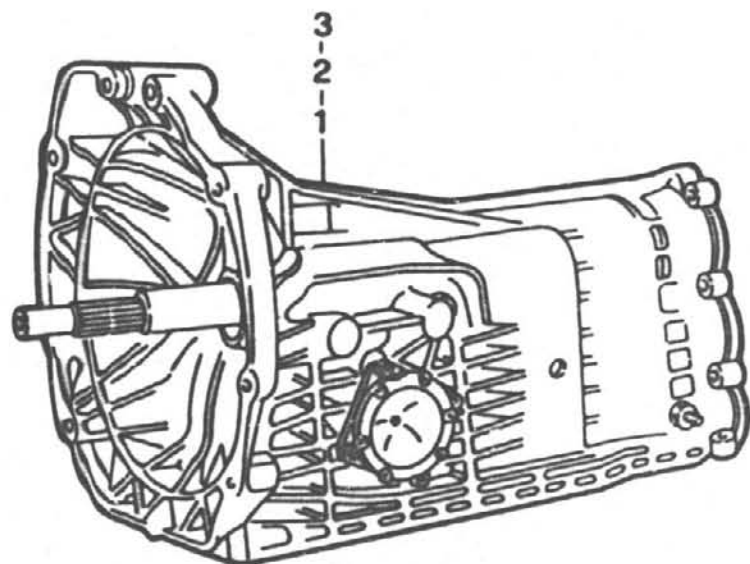

| pos. | TEILNUMMER | ref. | mg. benennung |
|------|-------------|------|------------------|
| 1 | 00966 09988 | ● | 1 GETRIEBE 10/37 |
| 2 | 00966 09989 | ▲ | 1 GETRIEBE 9/37 |
| 3 | 00607 50457 | ☐ | 1 GETRIEBE 9/35 |

● c.c. 1.7
▲ c.c. 1.3
☐ I.E.

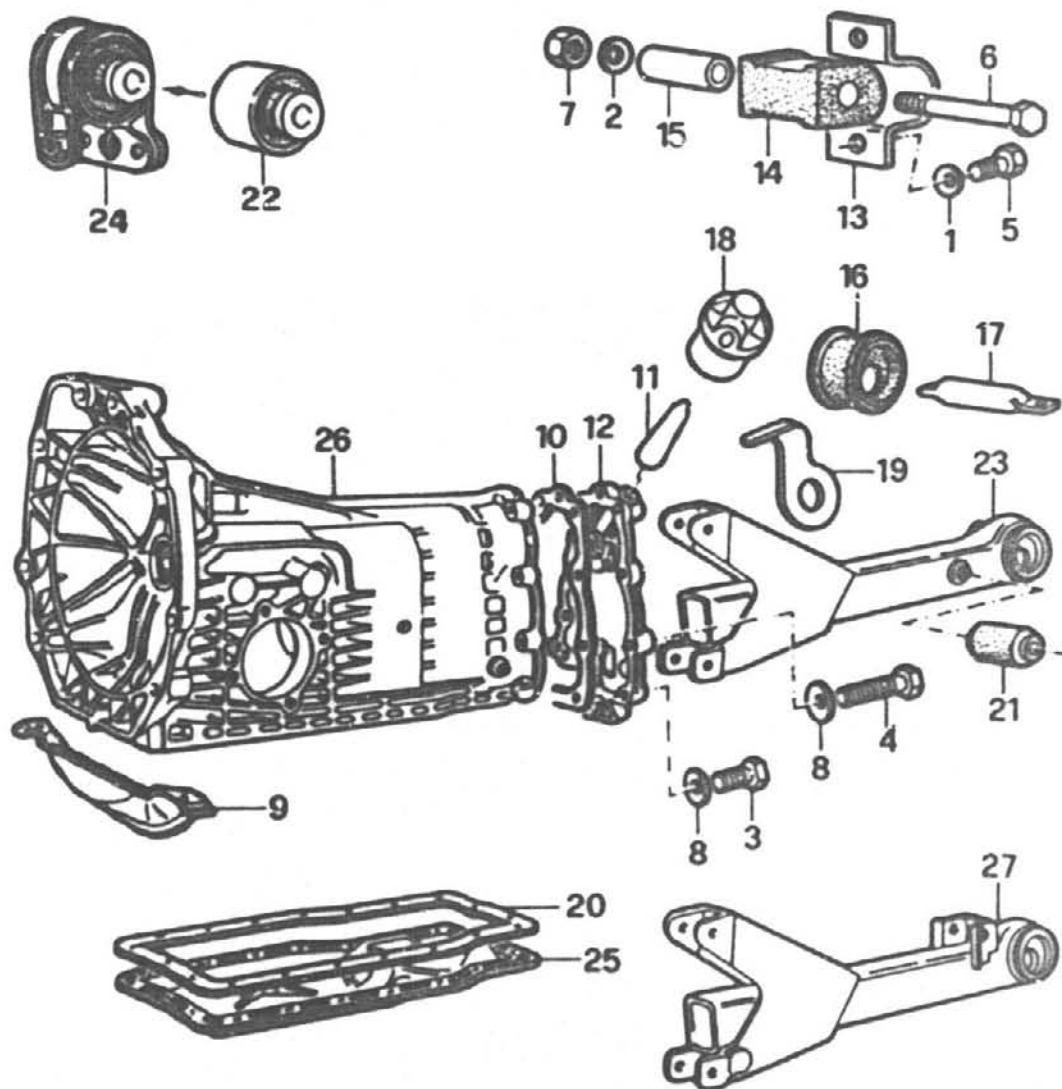

| pos. | TEILNUMMER | ref. | mg. benennung |
|------|------------------------------|------|------------------|
| 1 | 02100 81434 00 00 | | 3 SCHEIBE |
| 2 | 02100 81437 00 00 | | 2 SCHEIBE |
| 3 | 02105 02010 00 00 | | 5 SCHRAUBE |
| 4 | 00160 44121 | | 4 SCHRAUBE |
| 5 | 00160 43221 | | 4 SCHRAUBE |
| 6 | 00159 71421 | | 2 SCHRAUBE |
| 7 | 00121 64721 | | 2 MUTTER |
| 8 | 00126 01379 | | 9 SCHEIBE |
| 9 | 00605 02924 | | 1 DECKEL |
| 10 | 00605 02532 | | 1 DICHTUNG |
| 11 | 00605 02535 | | 1 VENTIL |
| 12 | 00605 02536 | | 1 DECKEL |
| 13 | 00605 02537 | | 2 LAGERBOCK |
| 14 | 00605 02538 | | 2 ZWISCHENSTUECK |
| 15 | 00605 02539 | | 2 FEDERBUECHSE |
| 16 | 00605 01314 | | 1 FEDERBUECHSE |
| 17 | 00605 17489 | | 1 BOLZEN |
| 18 | 00605 02543 | | 1 STOPFEN |
| 19 | 00605 02544 | | 1 PLAETTCHEN |
| 20 | 00605 02545 | | 1 DICHTUNG |
| 21 | 00605 02551 | ☐ | 1 FEDERBUECHSE |
| 22 | 00605 01320 | | 1 FEDERBUECHSE |
| 23 | 00605 01286 | ☐ | 1 LAGERUNG |
| 24 | 00605 01325 | | 1 LAGERUNG |
| 25 | 00605 02554 | | 1 OELWANNE |



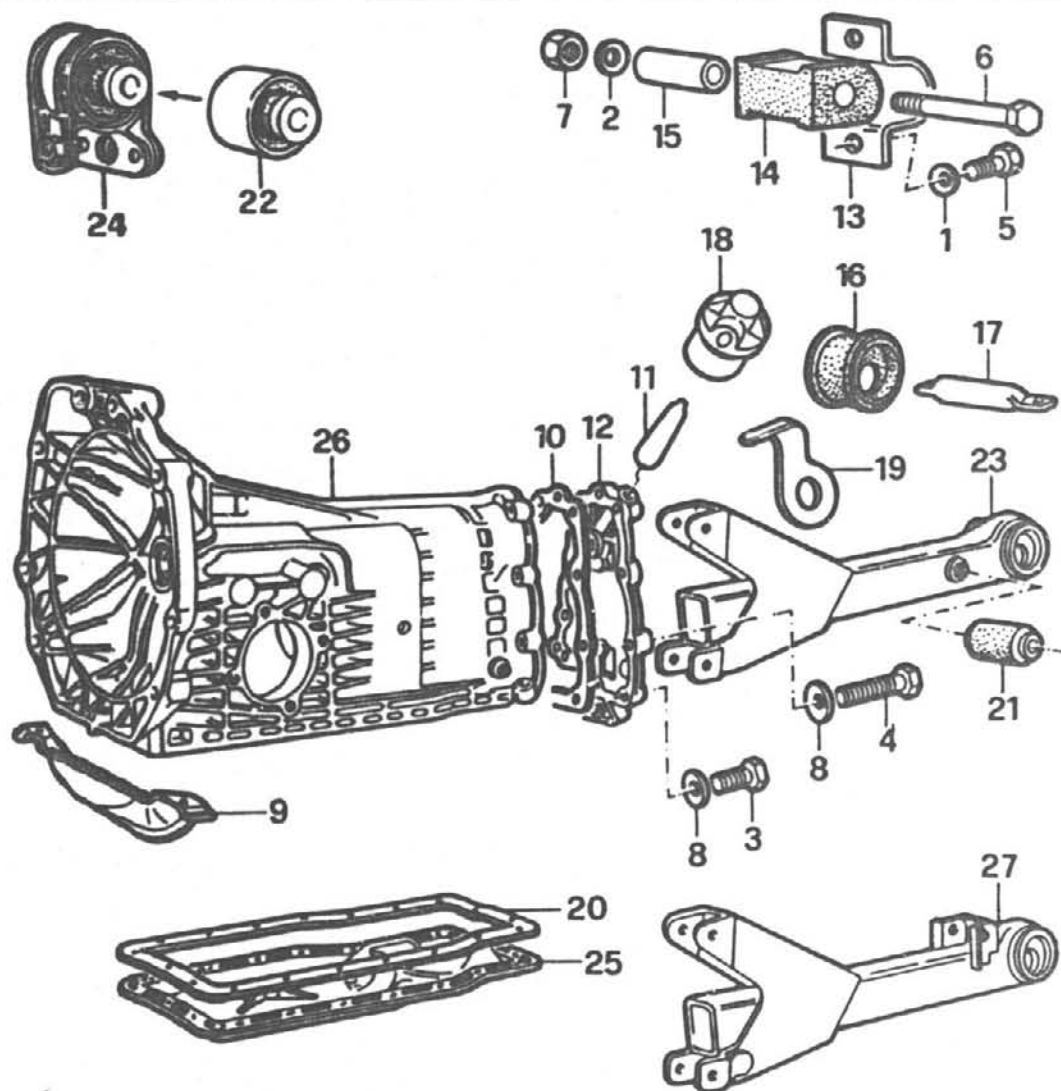

| pos. | TEILNUMMER | ref. | mg. | benennung | ↑ |
|------|-------------|------|-----|-----------------|---|
| 26 | 00966 09976 | | 1 | GETRIEBEGEHAUSE | |
| 27 | 00605 01287 | ☐ | 1 | LAGERUNG | |

M₄

SPRINT
Ed. 87
Meccanica

1-1989

TAV. 12.02

c.c. 32

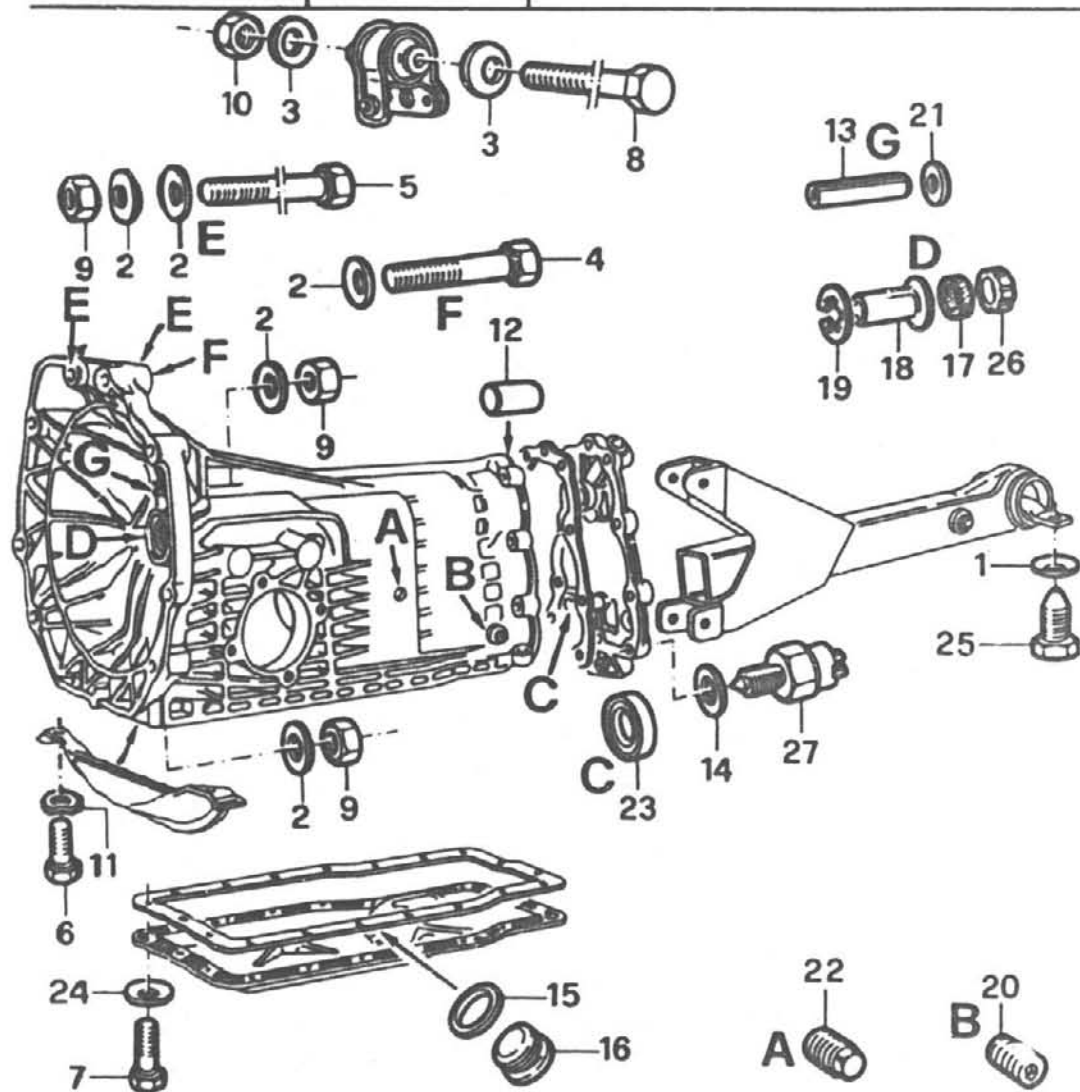

| pos. | TEILNUMMER | ref. | mg. benennung |
|------|-------------------|------|---------------|
| 1 | 02100 81434 00 00 | | 15 SCHEIBE |
| 2 | 02100 81437 00 00 | | 13 SCHEIBE |
| 3 | 00111 82479 | | 2 SCHEIBE |
| 4 | 00158 88721 | | 1 SCHRAUBE |
| 5 | 00159 72421 | | 1 SCHRAUBE |
| 6 | 00109 02121 | | 3 SCHRAUBE |
| 7 | 00109 02321 | | 19 SCHRAUBE |
| 8 | 00161 43421 | | 1 SCHRAUBE |
| 9 | 00121 64711 | | 5 MUTTER |
| 10 | 02125 15042 00 00 | | 1 MUTTER |
| 11 | 00126 01279 | | 3 SCHEIBE |
| 12 | 00605 26036 | | 2 PASSTIFT |
| 13 | 00139 40870 | | 1 STIFT |
| 14 | 00102 80050 | | 1 DICHTUNG |
| 15 | 00102 63450 | | 1 DICHTUNG |
| 16 | 00102 75040 | | 1 STOPFEN |
| 17 | 00605 02526 | | 1 DICHTRING |
| 18 | 00605 02527 | | 1 LAGERUNG |
| 19 | 00605 02528 | | 1 SPRENGRING |
| 20 | 00605 02622 | | 1 STOPFEN |
| 21 | 00605 02529 | | 1 PLAETTCHEN |
| 22 | 10142 40000 00 00 | | 1 STOPFEN |
| 23 | 00605 02531 | | 1 DICHTRING |
| 24 | 00605 02533 | | 19 SCHEIBE |
| 25 | 00605 01312 | | 2 SCHRAUBE |

M5

SPRINT
Ed. 87
Meccanica

1-1989

TAV. 12.02

c.c. 32

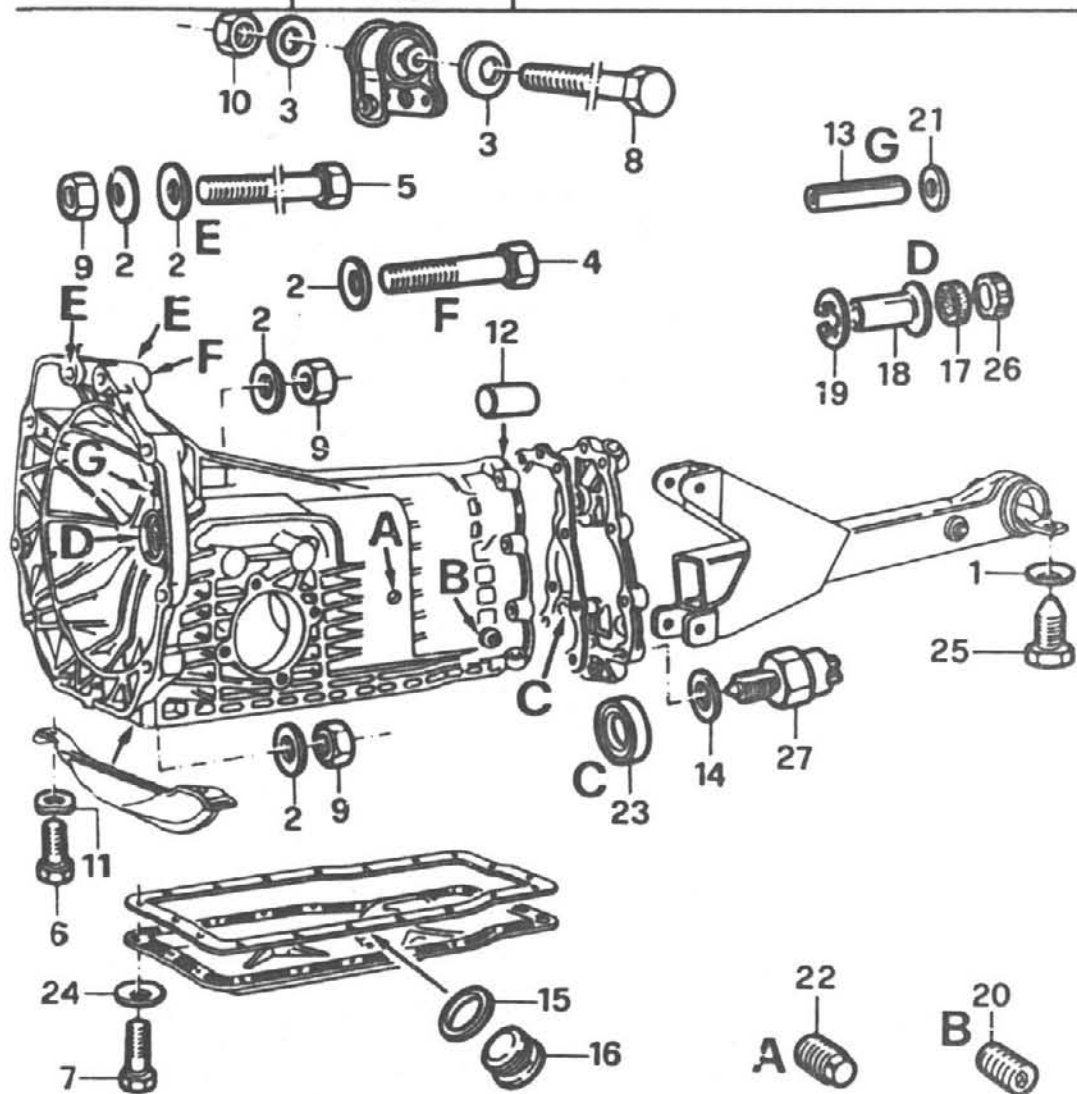

| pos. | TEILNUMMER | ref. | mg. benennung | ↑ |
|------|-------------------|------|---------------|---|
| 26 | 00605 02550 | | 1 DICHTRING | |
| 27 | 51093 10000 00 00 | | 1 SCHALTER | |

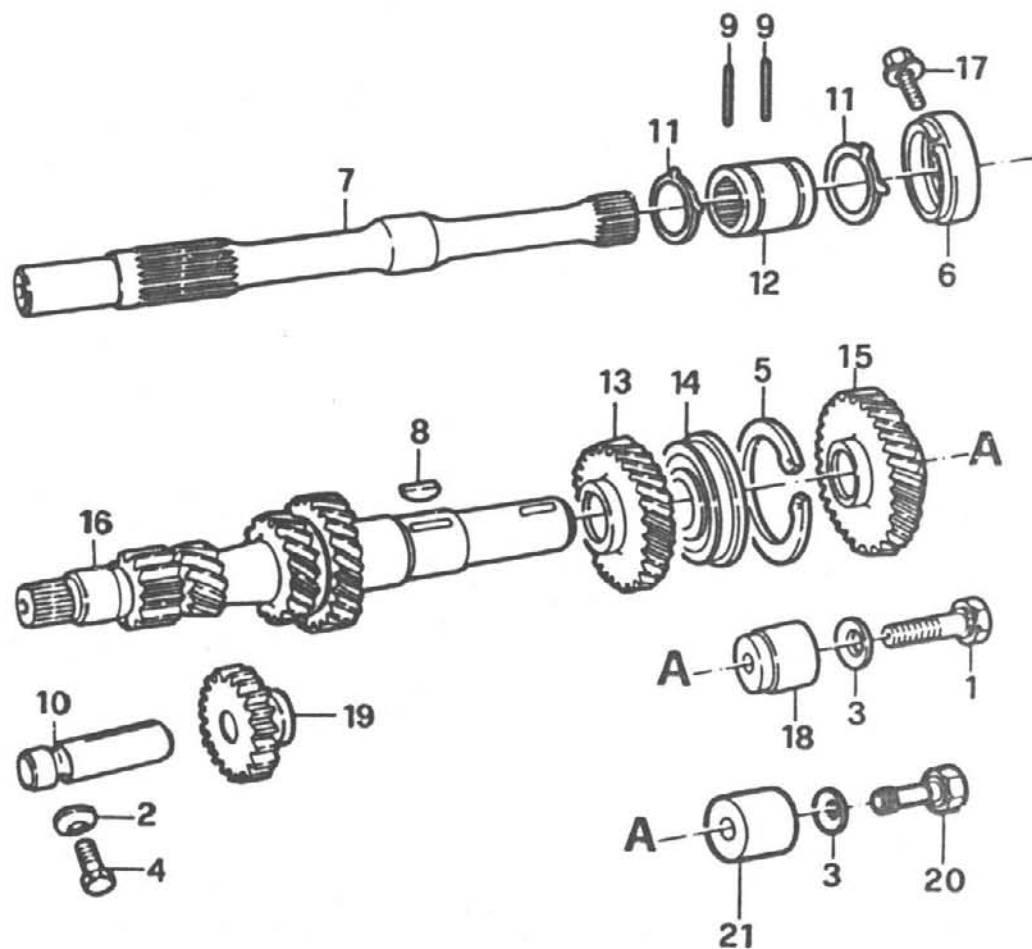

| pos. | TEILNUMMER | ref. | mg. | benennung |
|------|-------------------|------|-----|---------------|
| 1 | 00155 40523 | « | 1 | SCHRAUBE |
| 2 | 02100 81434 00 00 | | 1 | SCHEIBE |
| 3 | 02100 81440 00 00 | | 1 | SCHEIBE |
| 4 | 00160 43921 | | 1* | SCHRAUBE |
| 5 | 00110 61370 | | 1 | RING |
| 6 | 00605 02556 | | 1 | LAGER |
| 7 | 00605 01248 | | 1 | ANTRIEBSWELLE |
| 8 | 00605 02597 | | 1 | ZUNGE |
| 9 | 00605 02598 | | 2 | STIFT |
| 10 | 00605 02600 | R | 1 | WELLE |
| 11 | 00605 02604 | | 2 | FEDER |
| 12 | 00605 02605 | | 1 | BUECHSE |
| 13 | 00605 02610 | 4 | 1 | ZAHNRAD |
| 14 | 00605 02608 | | 1 | ZAHNRAD |
| 15 | 00605 01250 | 5 | 1 | ZAHNRAD |
| 16 | 00605 01251 | | 1 | HAUPTWELLE |
| 17 | 00605 02615 | | 1 | SCHRAUBE |
| 18 | 00966 09943 | « | 1 | TELLEP. |
| 19 | 00605 01270 | R | 1 | ZAHNRAD |
| 20 | 00605 25879 | » | 1 | SCHRAUBE |
| 21 | 00605 43686 | » | 1 | TELLER |

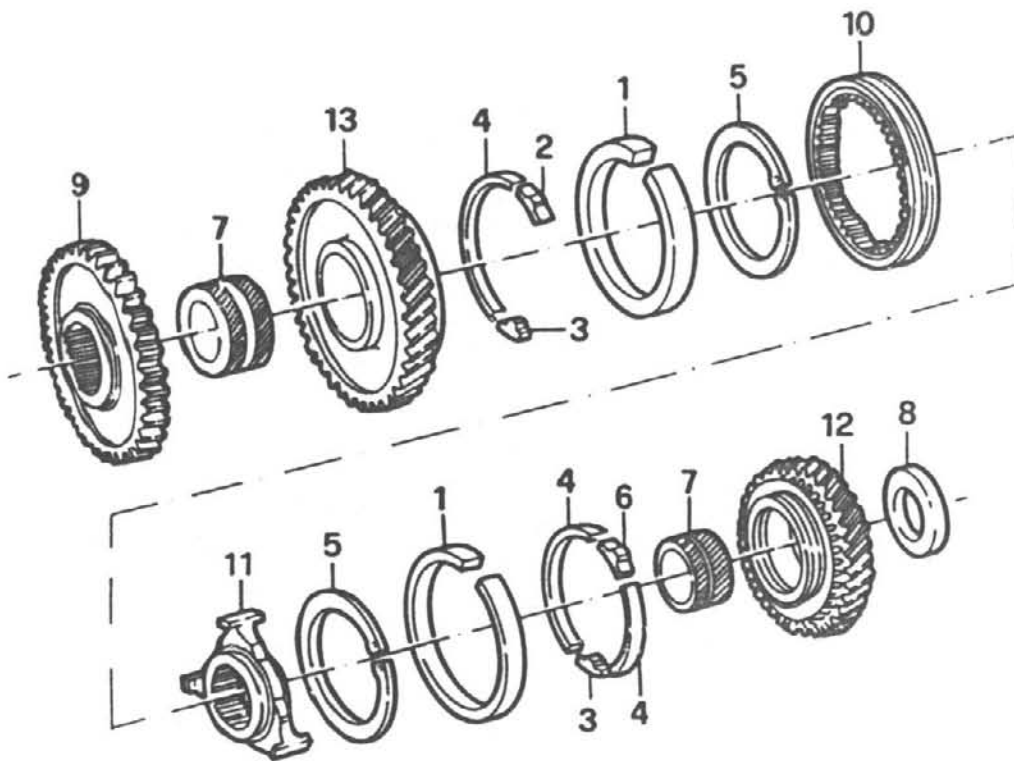

| pos. | TEILNUMMER | ref. | mg. benennung |
|------|-------------|------|--------------------|
| 1 | 00605 02557 | | 2 SYNCHRONISIERUNG |
| 2 | 00605 02558 | | 1 SPERRSTEIN |
| 3 | 00605 02559 | | 2 SPERRSTEIN |
| 4 | 00605 02560 | | 3 BAND |
| 5 | 00605 02561 | | 2 SPRENGRING |
| 6 | 00605 02562 | | 1 SPERRSTEIN |
| 7 | 00605 02563 | 1 2 | 2 BUECHSE |
| 8 | 00605 02601 | | 1 SCHEIBE |
| 9 | 00605 01269 | R | 1 ZAHNRAD |
| 10 | 00605 01271 | | 1 SCMALTMUFFE |
| 11 | 00605 01272 | 1 2 | 1 NABE |
| 12 | 00605 01259 | 2 | 1 ZAHNRAD |
| 13 | 00605 01266 | 1 | 1 ZAHNRAD |

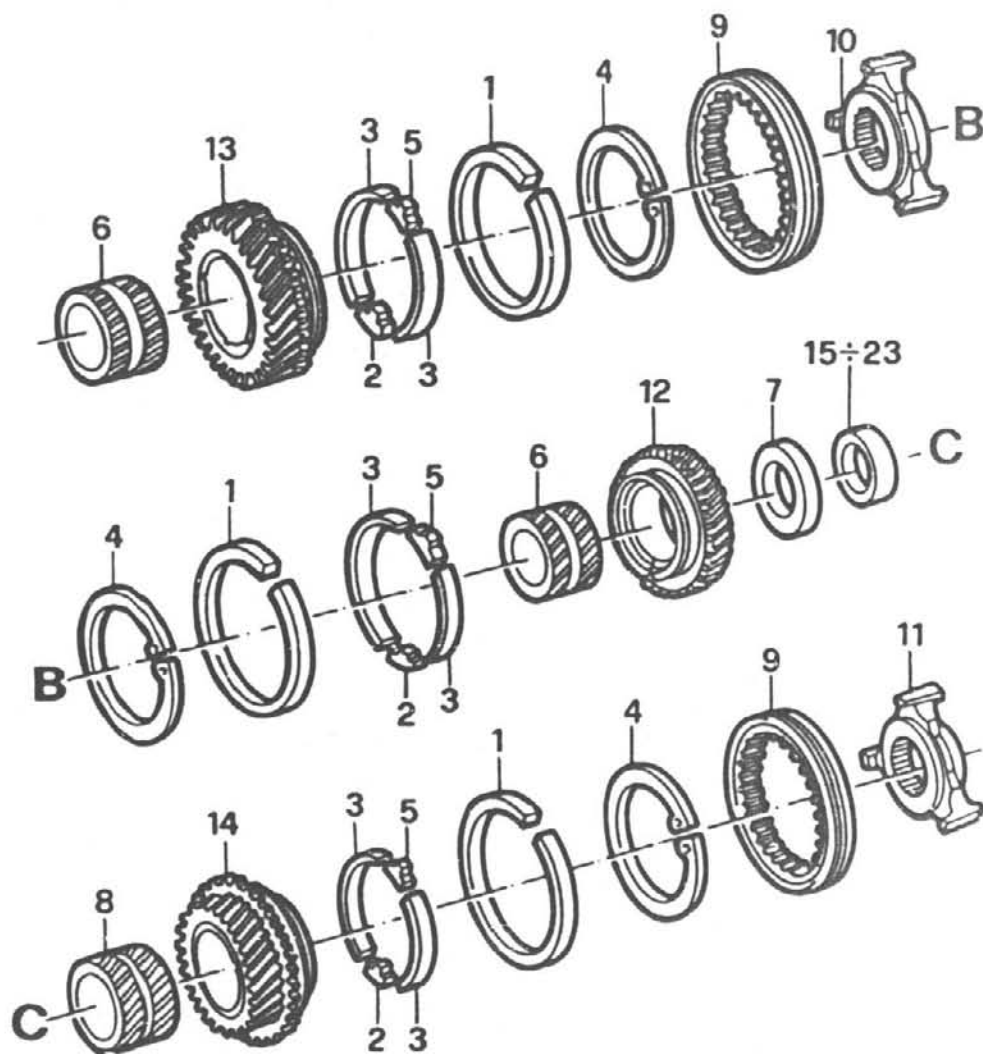

| pos. | TEILNUMMER | ref. | mg. benennung |
|------|-------------|------|-----------------------|
| 1 | 00605 02557 | | 3 SYNCHRONISIERUNG |
| 2 | 00605 02559 | | 3 SPERRSTEIN |
| 3 | 00605 02560 | | 6 BAND |
| 4 | 00605 02561 | | 3 SPRENGRING |
| 5 | 00605 02562 | | 3 SPERRSTEIN |
| 6 | 00605 02563 | 3 4 | 2 BUECHSE |
| 7 | 00605 02564 | | 1 BORDSCHEIBE |
| 8 | 00605 02596 | 5 | 1 BUECHSE |
| 9 | 00605 01271 | | 2 SCMALTMUFFE |
| 10 | 00605 01272 | 3 4 | 1 NABE |
| 11 | 00605 04673 | 5 | 1 NABE |
| 12 | 00605 02618 | 4 | 1 ZAHNRAD |
| 13 | 00605 01260 | 3 | 1 ZAHNRAD |
| 14 | 00605 01261 | 5 | 1 ZAHNRAD |
| 15 | 00607 48292 | | AUSGLEICH SP. 4,10 MM |
| 16 | 00607 48293 | | AUSGLEICH SP. 4,15 MM |
| 17 | 00607 48294 | | AUSGLEICH SP. 4,25 MM |
| 18 | 00607 48295 | | AUSGLEICH SP. 4,35 MM |
| 19 | 00607 48296 | | AUSGLEICH SP. 4,45 MM |
| 20 | 00607 48297 | | AUSGLEICH SP. 4,55 MM |
| 21 | 00607 48298 | | AUSGLEICH SP. 4,65 MM |
| 22 | 00607 48299 | | AUSGLEICH SP. 4,75 MM |
| 23 | 00607 48300 | | AUSGLEICH SP. 4,80 MM |

M10

SPRINT
Ed. 87
Meccanica

1-1989

TAV. 12.20

c.c. 32

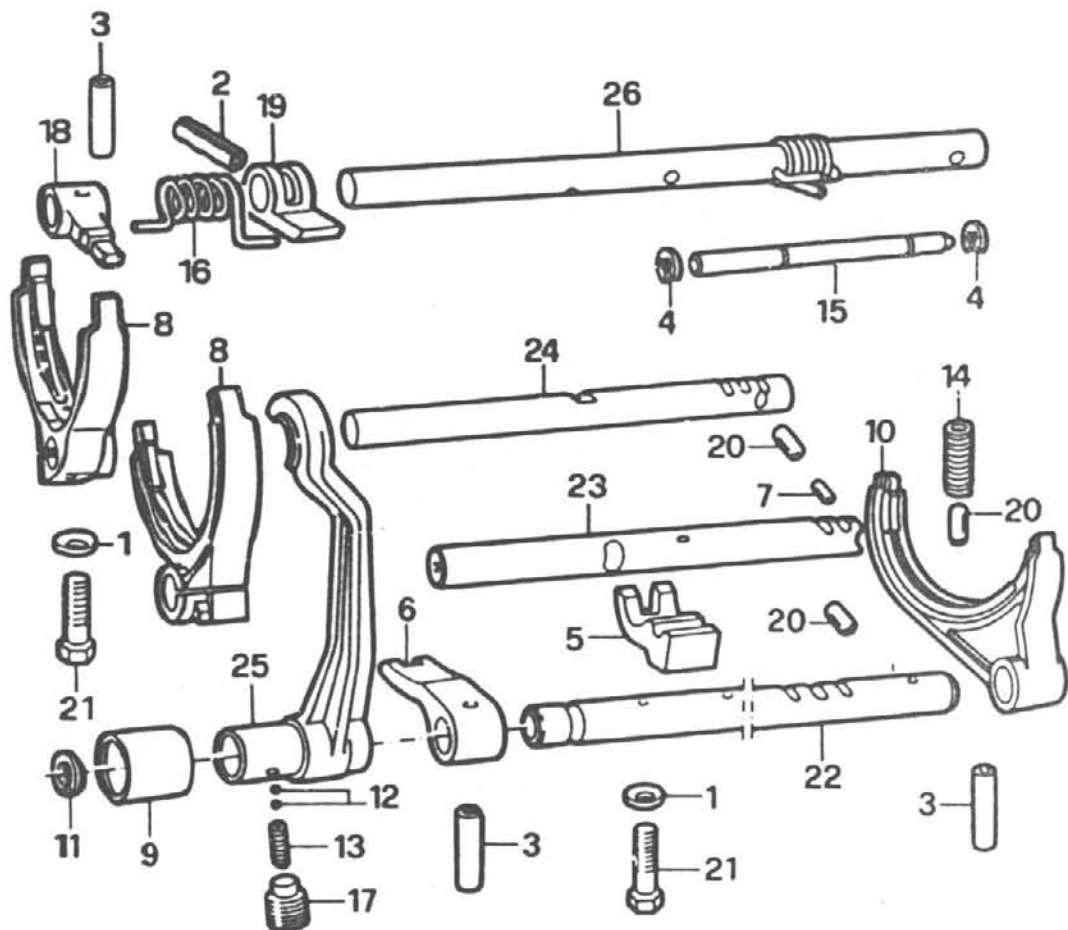

| pos. | TEILNUMMER | ref. | mg. benennung | ↑ |
|------|-------------|------|---------------|---|
| 26 | 00605 02640 | | 1 HEBEL | |

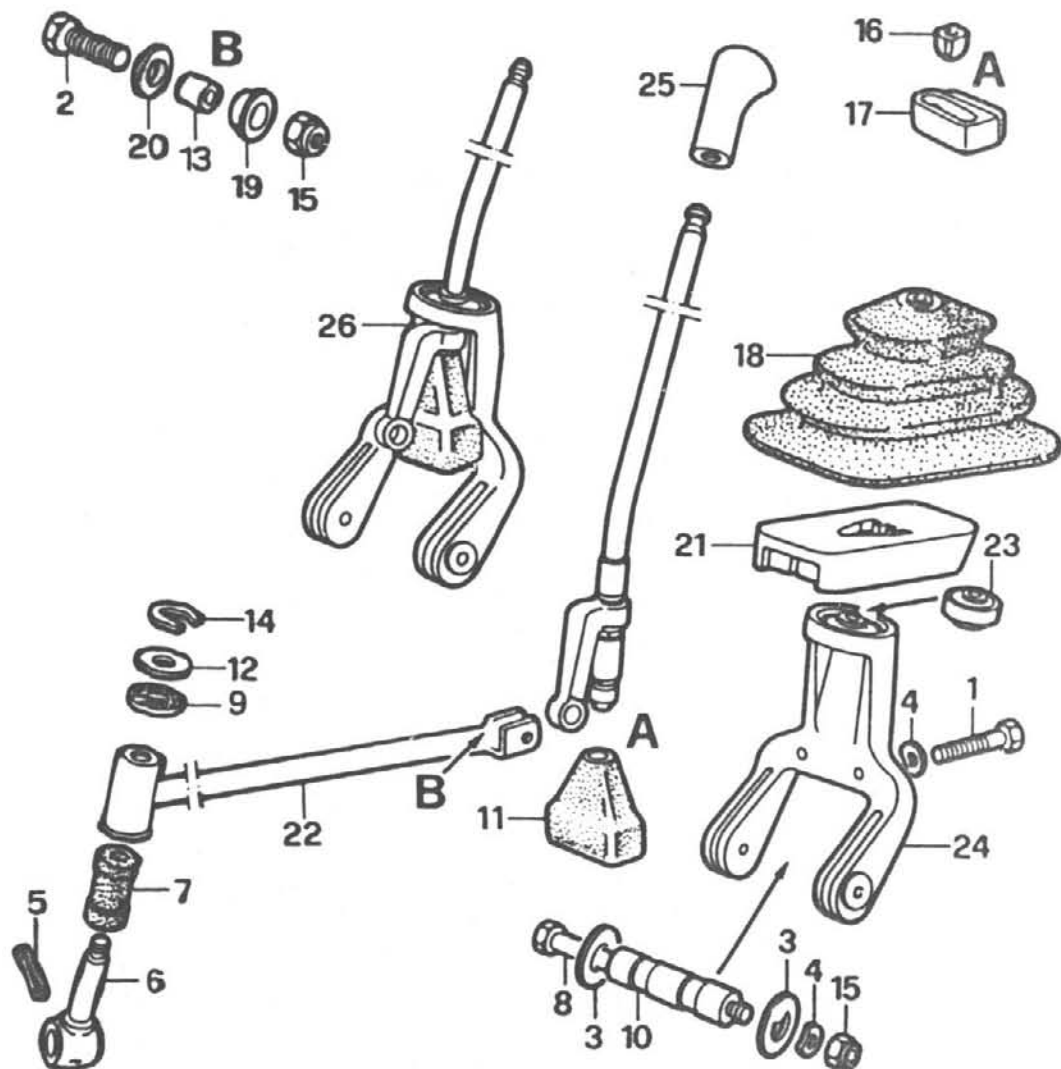

| pos. | TEILNUMMER | ref. | mg. | benennung |
|------|-------------|------|-----|---------------------|
| 1 | 00109 02621 | | 2 | SCHRAUBE |
| 2 | 00109 02721 | | 1 | SCHRAUBE |
| 3 | 00135 79771 | | 2 | SCHEIBE |
| 4 | 00126 01279 | | 4 | SCHEIBE |
| 5 | 00146 01070 | | 1 | STIFT |
| 6 | 00605 02641 | | 1 | AUSGLEICHDREHZAPFEN |
| 7 | 00605 02642 | | 1 | GUMMITEIL |
| 8 | 00605 02644 | | 1 | SCHRAUBE |
| 9 | 00605 02645 | | 1 | DICHTRING |
| 10 | 00605 02646 | | 1 | BUECHSE |
| 11 | 00605 02647 | | 1 | SCHMUTZFAENGER |
| 12 | 00605 02648 | | 1 | SCHEIBE |
| 13 | 00605 04727 | | 1 | ABSTANDSTUECK |
| 14 | 00605 02651 | | 1 | ANSCHLAG |
| 15 | 00605 02652 | | 1 | MUTTER |
| 16 | 00605 01622 | | 1 | FUEHRUNGSBOLZEN |
| 17 | 00605 01623 | | 1 | SITZ |
| 18 | 00605 01625 | | 1 | SCHUTZKAPPE |
| 19 | 00605 04725 | | 1 | BUECHSE |
| 20 | 00605 04726 | | 1 | SCHEIBE |
| 21 | 00605 01626 | | 1 | ABDECKUNG |
| 22 | 00605 04723 | | 1 | STANGE |
| 23 | 00605 02654 | | 1 | FEDERBUECHSE |
| 24 | 00605 02655 | | 1 | GABEL |
| 25 | 00605 01634 | | 1 | KNOPF |



M12

SPRINT
Ed. 87
Meccanica

1-1989

TAV. 12.22

c.c. 32

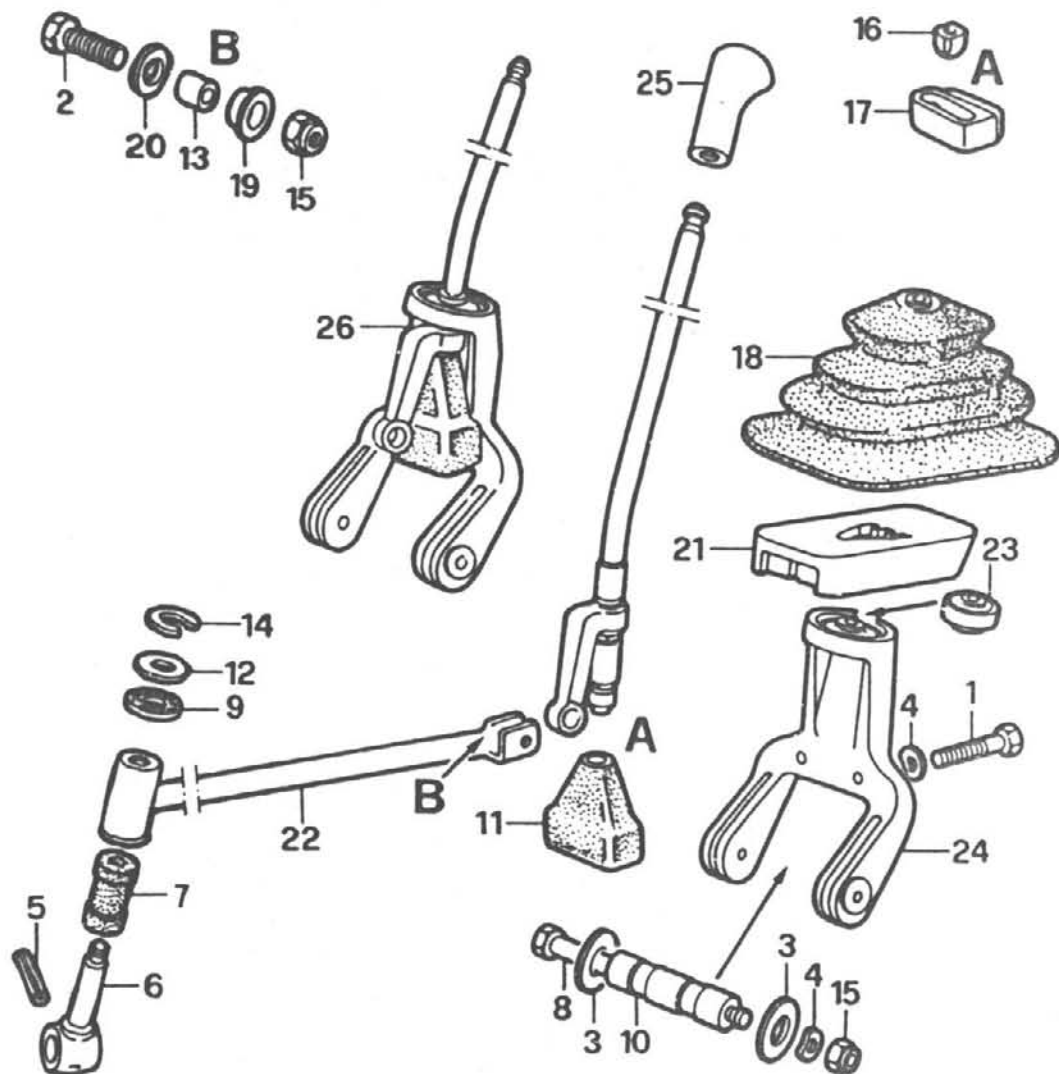

| pos. | TEILNUMMER | ref. | mg. | benennung | |
|------|-------------|------|-----|-----------|---|
| 26 | 00605 01637 | | 1 | HEBEL | ↑ |

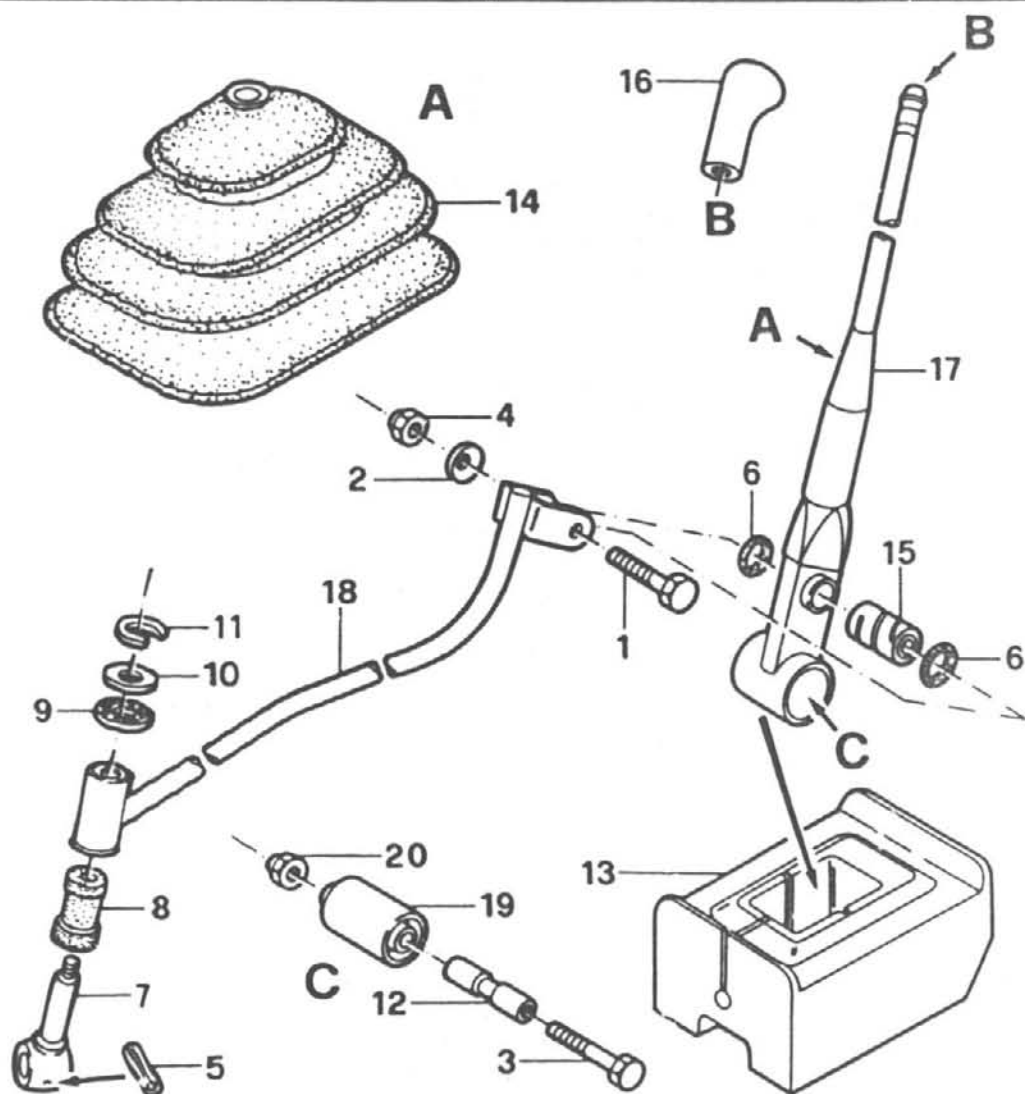

| pos. | TEILNUMMER | ref. | mg. | benennung |
|------|-------------------|------|-----|---------------|
| 1 | 00152 48423 | | 1 | SCHRAUBE |
| 2 | 02100 81431 00 00 | | 1 | SCHEIBE |
| 3 | 00109 03721 | | 1 | SCHRAUBE |
| 4 | 00161 12211 | | 1 | MUTTER |
| 5 | 00146 01070 | | 1 | FEDERSTIFT |
| 6 | 00144 52980 | | 2 | O-GUMMIRING |
| 7 | 00605 02641 | | 1 | HEBEL |
| 8 | 00605 02642 | | 1 | FEDERBUECHSE |
| 9 | 00605 02645 | | 1 | SCHEIBE |
| 10 | 00605 02648 | | 1 | SCHEIBE |
| 11 | 00605 02651 | | 1 | RING |
| 12 | 00605 01627 | | 1 | ABSTANDSTUECK |
| 13 | 00605 01628 | | 1 | PUFFER |
| 14 | 00605 01629 | | 4 | SCHUTZKAPPE |
| 15 | 00605 01642 | | 1 | ABSTANDSTUECK |
| 16 | 00605 01634 | | 1 | KNOPF |
| 17 | 00605 01639 | | 1 | HEBEL |
| 18 | 00605 01643 | | 1 | STANGE |
| 19 | 00605 01640 | | 1 | FEDERBUECHSE |
| 20 | 00605 02652 | | 1 | MUTTER |

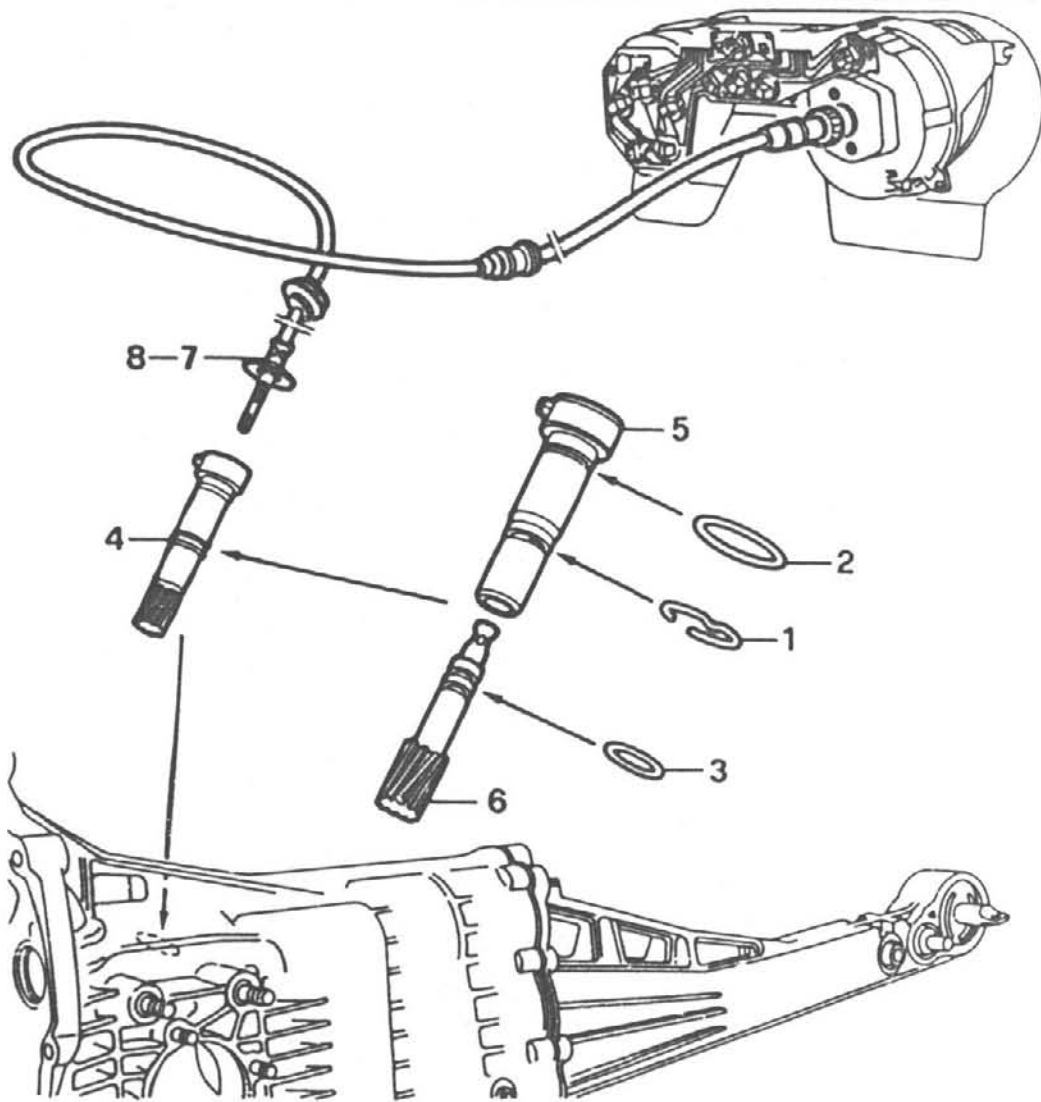

| pos. | TEILNUMMER | ref. | mg. benennung |
|------|-------------|------|---------------|
| 1 | 00605 15604 | | 1 FEDER |
| 2 | 00605 15666 | | 1 DICHTUNG |
| 3 | 00605 15667 | | 1 DICHTUNG |
| 4 | 00605 35943 | | 1 ZAHNRAD |
| 5 | 00605 35944 | | 1 HUELSE |
| 6 | 00605 35945 | | 1 ZAHNRAD |
| 7 | 00605 36320 | ● | 1 SEIL |
| 8 | 00605 36324 | ■ | 1 SEIL |

● G.S.

■ G.D.

N

1

TAV 14.10

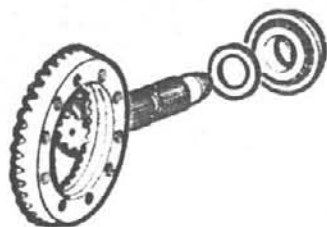

2

TAV 14.10

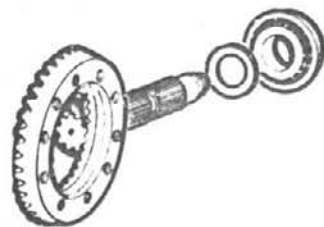

3

TAV 14.30

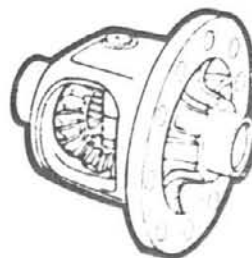

4

TAV 14.30

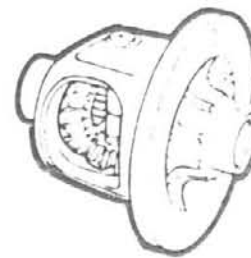

5

TAV

6

TAV 14.40



7

TAV 31.00

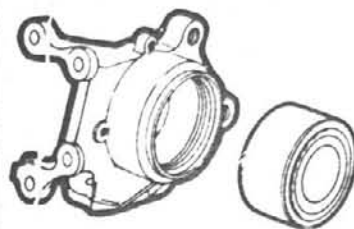

8

TAV

9

TAV

10

TAV

11

TAV

12

TAV

13

TAV

14

TAV

15

TAV

16

TAV

17

TAV

18

TAV

19

TAV

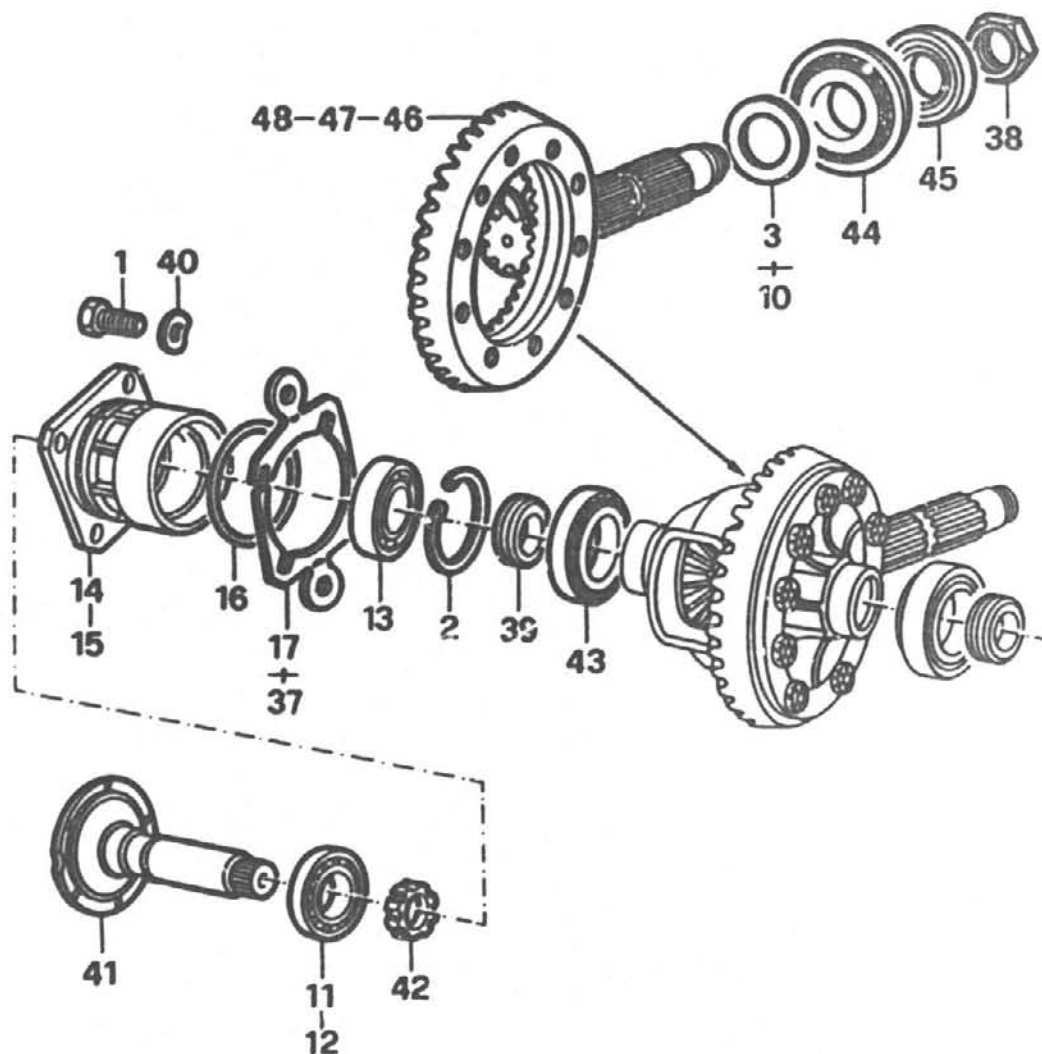

| pos. | TEILNUMMER | ret. | mg. benennung |
|------|-------------|------|-----------------------|
| 1 | 00113 06921 | | 8 SCHRAUBE |
| 2 | 00110 60870 | | 2 SPRENGRING |
| 3 | 00605 02925 | | AUSGLEICH SP. 0,75 MM |
| 4 | 00605 02926 | | AUSGLEICH SP. 0,80 MM |
| 5 | 00605 02927 | | AUSGLEICH SP. 0,85 MM |
| 6 | 00605 02928 | | AUSGLEICH SP. 0,90 MM |
| 7 | 00605 02929 | | AUSGLEICH SP. 0,95 MM |
| 8 | 00605 02930 | | AUSGLEICH SP. 1,00 MM |
| 9 | 00605 02931 | | AUSGLEICH SP. 1,05 MM |
| 10 | 00605 02932 | | AUSGLEICH SP. 1,10 MM |
| 11 | 00605 02669 | | 1 DICHRING |
| 12 | 00605 02670 | | 1 DICHRING |
| 13 | 00605 02672 | | 2 LAGER |
| 14 | 00605 15587 | ◆ | 1 LAGERUNG |
| 15 | 00605 02673 | ◆ | 1 LAGERUNG |
| 16 | 00605 02674 | | 2 DICHRING |
| 17 | 00605 02675 | | BORDSCHEIBE SP. 1,00 |
| 18 | 00605 02676 | | BORDSCHEIBE SP. 1,05 |
| 19 | 00605 02677 | | BORDSCHEIBE SP. 1,10 |
| 20 | 00605 02678 | | BORDSCHEIBE SP. 1,15 |
| 21 | 00605 02679 | | BORDSCHEIBE SP. 1,20 |
| 22 | 00605 02680 | | BORDSCHEIBE SP. 1,25 |
| 23 | 00605 02681 | | BORDSCHEIBE SP. 1,30 |
| 24 | 00605 02682 | | BORDSCHEIBE SP. 1,35 |
| 25 | 00605 02683 | | BORDSCHEIBE SP. 1,40 |



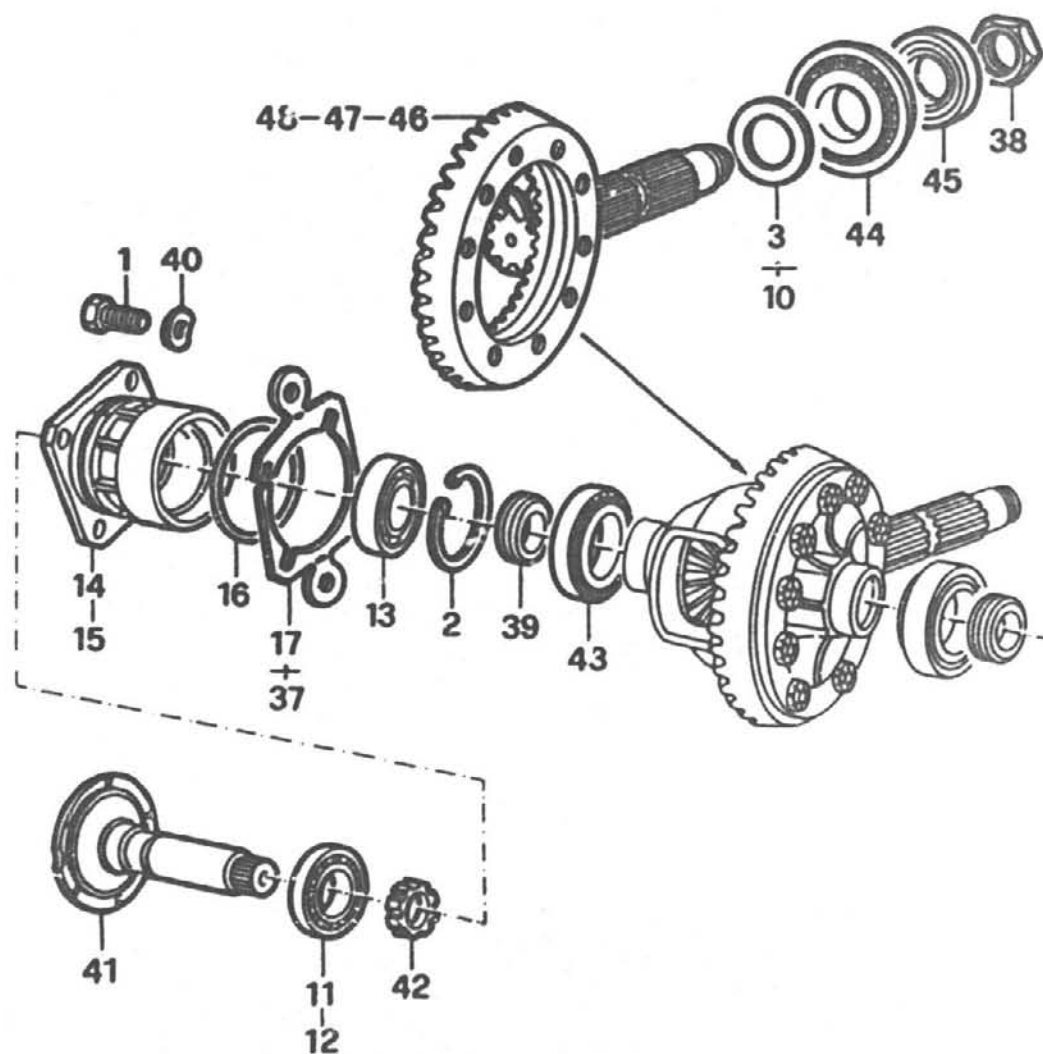

| pos. | TEILNUMMER | ref. | mg. benennung | ↑ |
|------|-------------|------|--------------------------|---|
| 26 | 00605 02684 | | BORDSCHEIBE SP. 1,45 | |
| 27 | 00605 02685 | ◆ | BORDSCHEIBE SP. 1,50 | |
| 28 | 00605 02686 | ◆ | BORDSCHEIBE SP. 1,55 | |
| 29 | 00605 02687 | | BORDSCHEIBE SP. 1,60 | |
| 30 | 00605 02688 | | BORDSCHEIBE SP. 1,65 | |
| 31 | 00605 02689 | | BORDSCHEIBE SP. 1,70 | |
| 32 | 00605 02690 | | BORDSCHEIBE SP. 1,75 | |
| 33 | 00605 02691 | | BORDSCHEIBE SP. 1,80 | |
| 34 | 00605 02692 | | BORDSCHEIBE SP. 1,85 | |
| 35 | 00605 02693 | | BORDSCHEIBE SP. 1,90 | |
| 36 | 00605 02694 | | BORDSCHEIBE SP. 1,95 | |
| 37 | 00605 02695 | | BORDSCHEIBE SP. 2,00 | |
| 38 | 00605 02702 | | 1 MUTTER | |
| 39 | 00605 02703 | | 2 DICHTRING | |
| 40 | 00605 02709 | | 8 SCHEIBE | |
| 41 | 00605 01291 | | 2 WELLE | |
| 42 | 00605 01278 | | 1 RAD | |
| 43 | 00605 02731 | | 2 LAGER | |
| 44 | 00605 02732 | | 1 LAGER | |
| 45 | 00605 02734 | | 1 LAGER | |
| 46 | 00605 14991 | | 1 KEGELRADGETRIEBE 10/37 | |
| 47 | 00605 04676 | | 1 KEGELRADGETRIEBE 9/37 | |
| 48 | 00605 05310 | ■ | 1 KEGELRADGETRIEBE 9/37 | |

◆ Rechts
◆ Links
■ I.E.

N₃

SPRINT
Ed. 87
Meccanica

1-1989

TAV. 14.30

c.c. 32

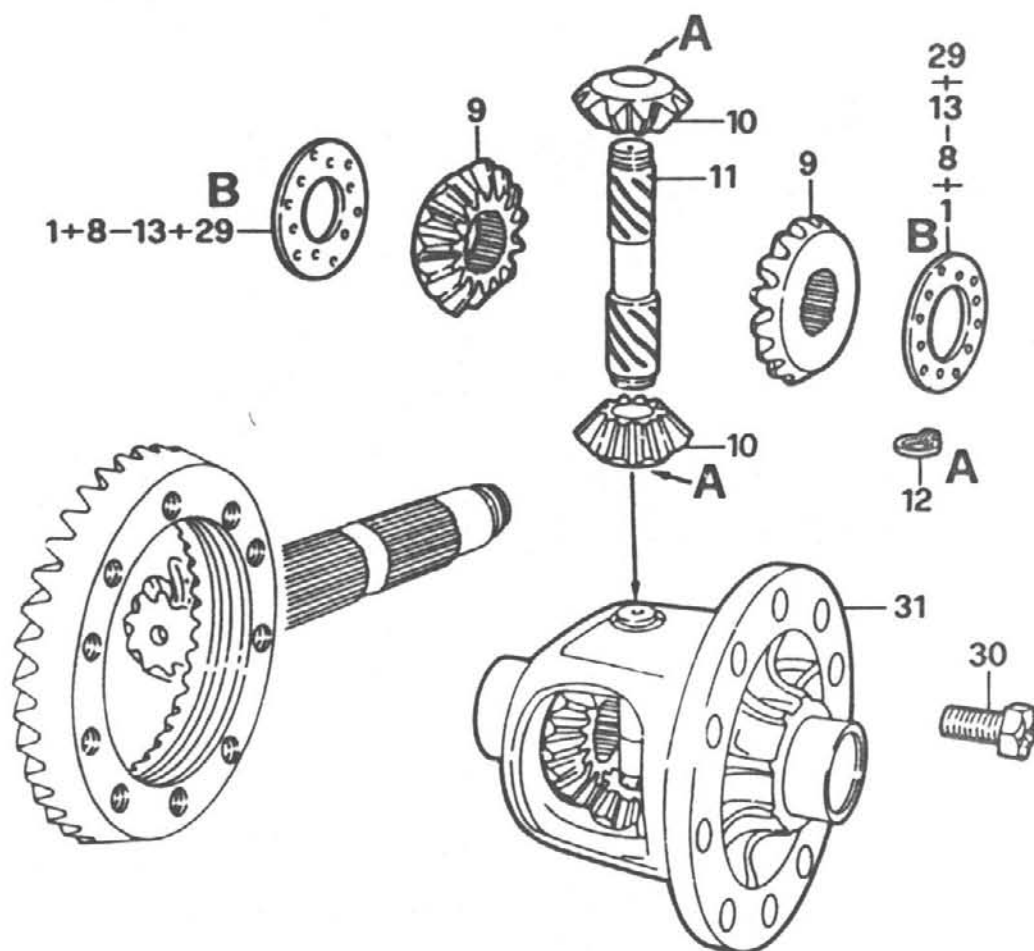

| pos. | TEILNUMMER | ref. | mg. benennung |
|------|------------------------|------|-----------------------|
| 1 | 00607 09439 | | AUSGLEICH SP. 0,50 MM |
| 2 | 00605 15589 | | AUSGLEICH SP. 0,55 MM |
| 3 | 00607 09440 | | AUSGLEICH SP. 0,60 MM |
| 4 | 00607 09441 | | AUSGLEICH SP. 0,65 MM |
| 5 | 00605 02696 | | AUSGLEICH SP. 0,70 MM |
| 6 | 00607 09442 | | AUSGLEICH SP. 0,75 MM |
| 7 | 00607 09443 | | AUSGLEICH SP. 0,80 MM |
| 8 | 00605 02697 | | AUSGLEICH SP. 0,85 MM |
| 9 | 00605 02698 | 2 | PLANETENRAD |
| 10 | 00605 02699 | 1 | SATELLITENRAD |
| 11 | 00605 02700 | 1 | BOLZEN |
| 12 | 00605 02706 | 2 | ARRETIERRING |
| 13 | 00605 02711 | | BEILAGSCH. 0,575 MM |
| 14 | 00605 02712 | | BEILAGSCH. 0,625 MM |
| 15 | 00605 02713 | | BEILAGSCH. 0,675 MM |
| 16 | 00605 02714 | | BEILAGSCH. 0,725 MM |
| 17 | 00605 02715 | | BEILAGSCH. 0,775 MM |
| 18 | 00605 02716 | | BEILAGSCH. 0,825 MM |
| 19 | 00605 02717 | | BEILAGSCH. 0,875 MM |
| 20 | 00605 18426 | | BEILAGSCH. 0,400 MM |
| 21 | 00605 18427 | | BEILAGSCH. 0,425 MM |
| 22 | 00605 18428 | | BEILAGSCH. 0,450 MM |
| 23 | 00605 18429 | | BEILAGSCH. 0,475 MM |
| 24 | 00605 18430 | | BEILAGSCH. 0,925 MM |
| 25 | 00605 18431 | | BEILAGSCH. 0,950 MM |



N4

SPRINT
Ed. 87
Meccanica
1-1989

TAV. 14.30

c.c. 32

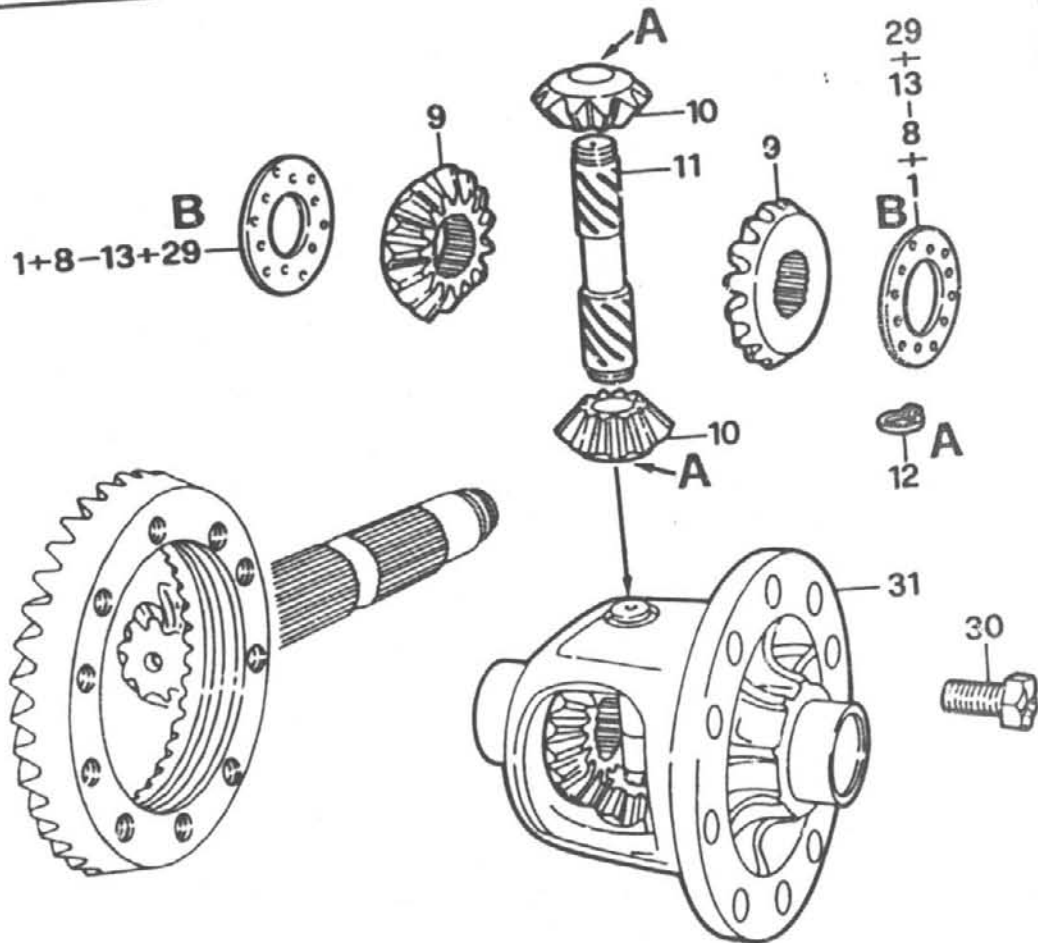

| pos. | TEILNUMMER | ref. | mg. | benennung | |
|------|-------------|------|-----|---------------------|---|
| 26 | 00605 18432 | | | BEILAGSCH. 0,975 MM | |
| 27 | 00605 18433 | | | BEILAGSCH. 0,100 MM | |
| 28 | 00605 02718 | | | BEILAGSCH. 0,970 MM | |
| 29 | 00605 02719 | | | BEILAGSCH. 1,000 MM | |
| 30 | 00605 21967 | | 8 | SCHRAUBE | |
| 31 | 00605 01290 | | 1 | DIFFERENTIALGEHAUSE | ↑ |

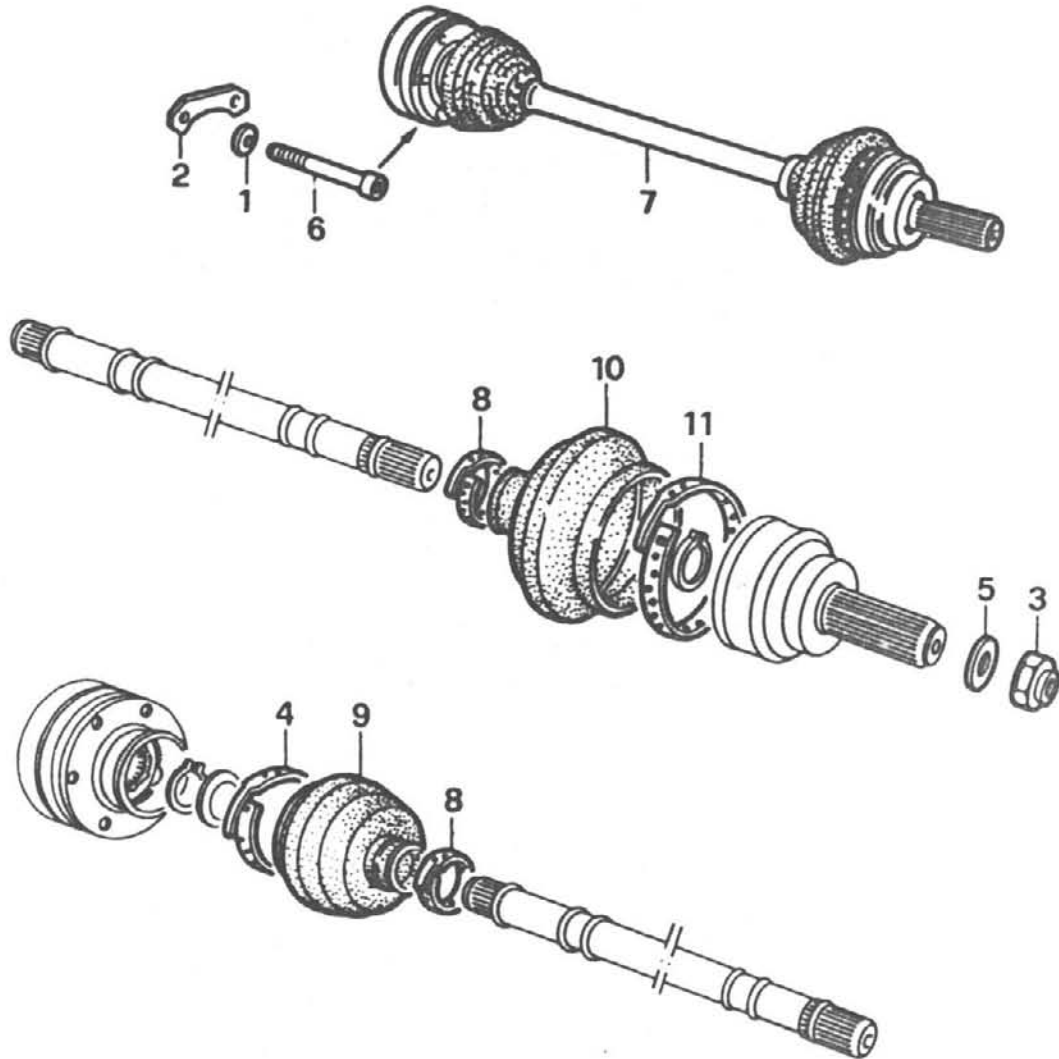

| pos. | TEILNUMMER | ref. | mg. benennung |
|------|-------------------|------|---------------|
| 1 | 02100 81434 00 00 | | 12 SCHEIBE |
| 2 | 00605 04686 | | 6 PLAETTCHEN |
| 3 | 00605 01297 | | 2 MUTTER |
| 4 | 00607 24033 | | 2 SCHELLE |
| 5 | 11600 25460 03 00 | | 2 SCHEIBE |
| 6 | 11655 17318 01 00 | | 12 SCHRAUBE |
| 7 | 00605 04718 | | 2 HALBWELLE |
| 8 | 00607 48265 | | 4 SCHELLE |
| 9 | 00607 48583 | | 2 MANICHETTE |
| 10 | 00607 49591 | | 2 MANICHETTE |
| 11 | 00607 49592 | | 2 SCHELLE |

N₇

SPRINT
Ed. 87
Meccanica

1-1999

TAV. 31.00

c.c. 32

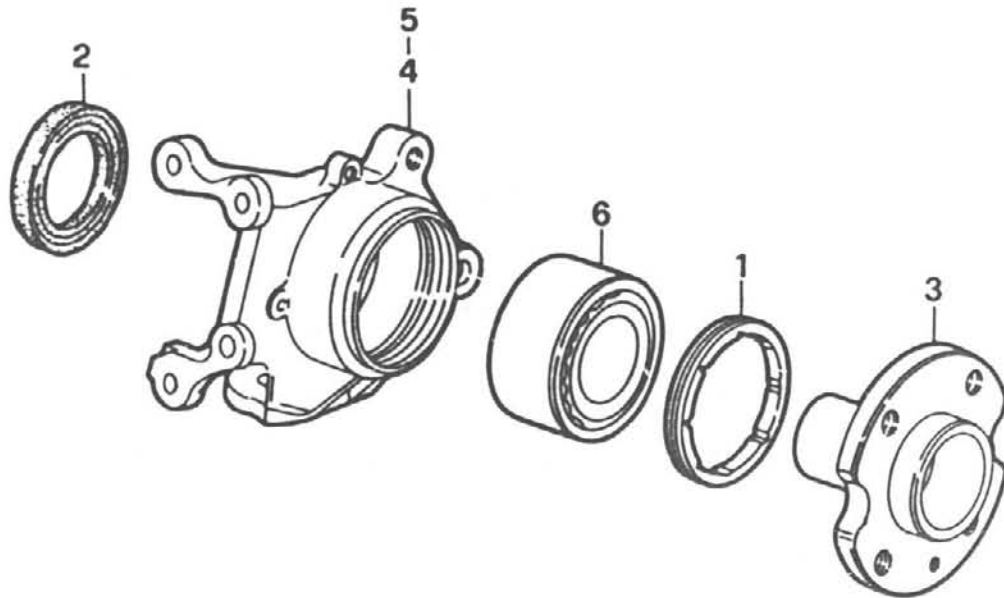

| pos. | TEILNUMMER | ref. | mg. benennung |
|------|-------------|------|---------------|
| 1 | 00605 01376 | | 2 RINGMUTTER |
| 2 | 00605 01377 | | 2 DICHRING |
| 3 | 00605 01373 | | 2 NABE |
| 4 | 00605 01382 | ◆ | 1 LAGERUNG |
| 5 | 00605 01383 | ◆ | 1 LAGERUNG |
| 6 | 00605 01385 | | 2 LAGER |

◆ Rechts
◆ Links

1

TAV 31.01

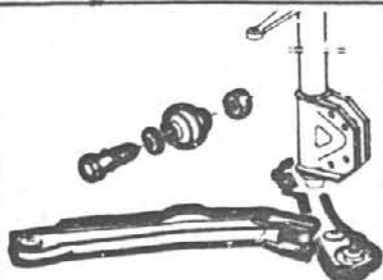

2

TAV 31.01/1

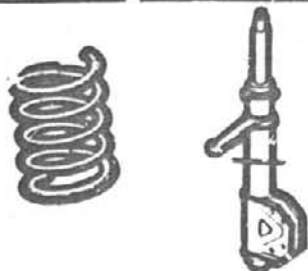

3

TAV 31.07

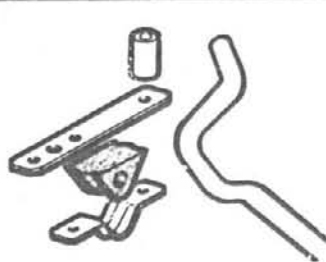

4

TAV

5

TAV 31.11

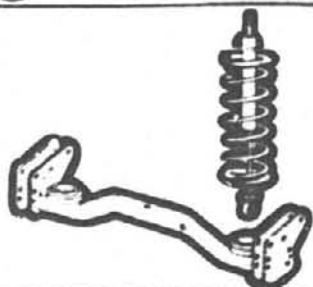

6

TAV 31.11

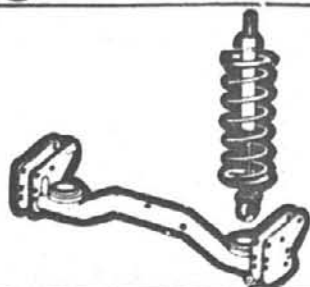

7

TAV 31.12

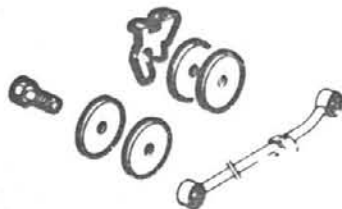

8

TAV

9

TAV

10

TAV 31.20

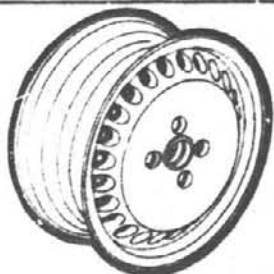

11

TAV

12

TAV

13

TAV

14

TAV

15

TAV

16

TAV

17

TAV

18

TAV

19

TAV

O1

SPRINT
Ed. 87
Meccanica

1-1-89

TAV. 31.01

c.c. 32

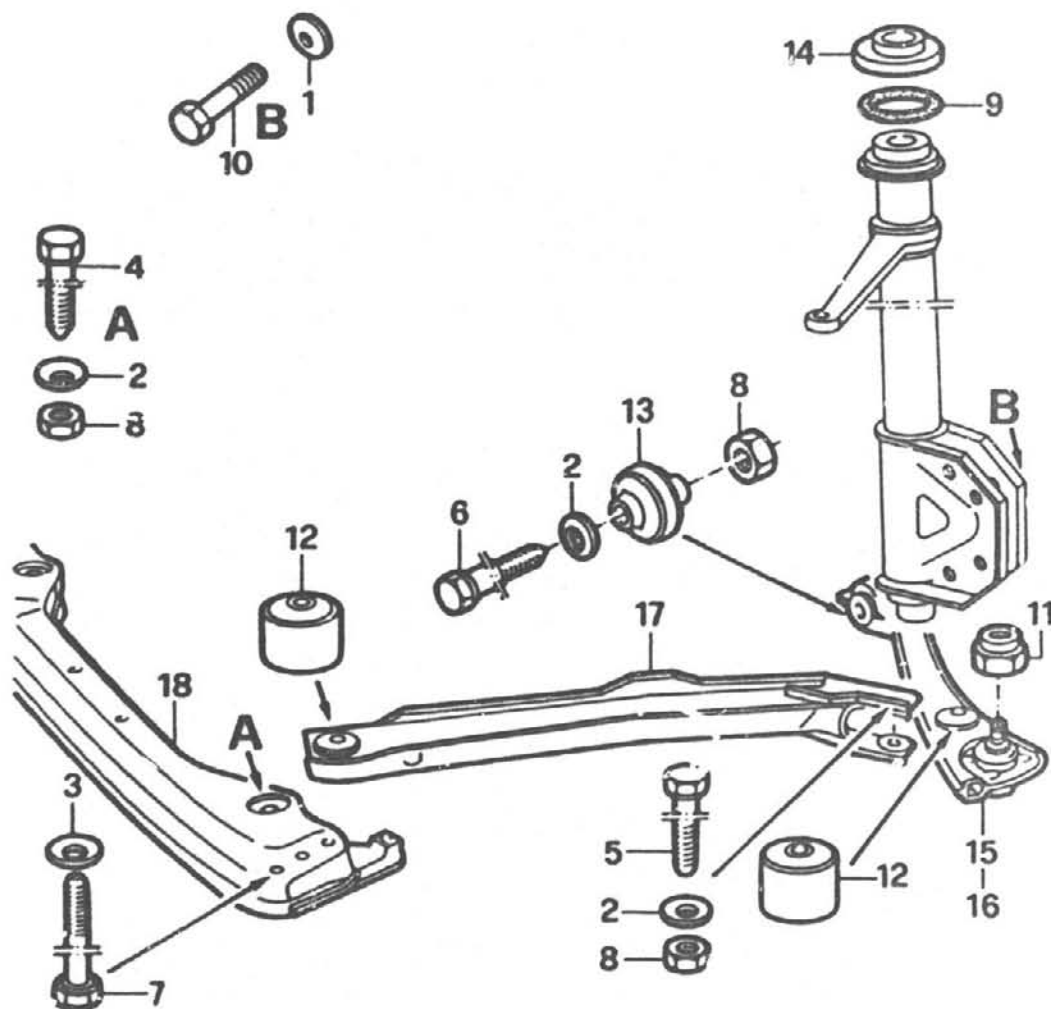

| pos. | TEILNUMMER | ref. | mq | benennung |
|------|-------------------|------|----|--------------|
| 1 | 02100 81437 00 00 | | 8 | SCHEIBE |
| 2 | 02100 81440 00 00 | | 4 | SCHEIBE |
| 3 | 00111 98779 | | 4 | SCHEIBE |
| 4 | 00155 41221 | | 2 | SCHRAUBE |
| 5 | 00155 41321 | | 2 | SCHRAUBE |
| 6 | 00161 43121 | | 4 | SCHRAUBE |
| 7 | 00161 43921 | | 2 | SCHRAUBE |
| 8 | 02125 15042 00 00 | | 6 | MUTTER |
| 9 | 02340 35068 | | 1 | DICHTUNG |
| 10 | 00605 01405 | | 8 | SCHRAUBE |
| 11 | 00605 01387 | | 2 | MUTTER |
| 12 | 00605 01394 | | 4 | SILENTBLOCK |
| 13 | 00605 01755 | | 2 | FEDERBUECHSE |
| 14 | 00605 01446 | | 2 | RING |
| 15 | 00605 01401 | ◆ | 1 | STREBE |
| 16 | 00605 01402 | ◆ | 1 | STREBE |
| 17 | 00605 01403 | | 1 | STUETZSTREBE |
| 18 | 00605 05797 | | 1 | QUERTRAEGER |

◆ Rechts

◆ Links

O₂

SPRINT
Ed. 87
Meccanica
1-1989

TAV. 31.01/1

c.c. 32

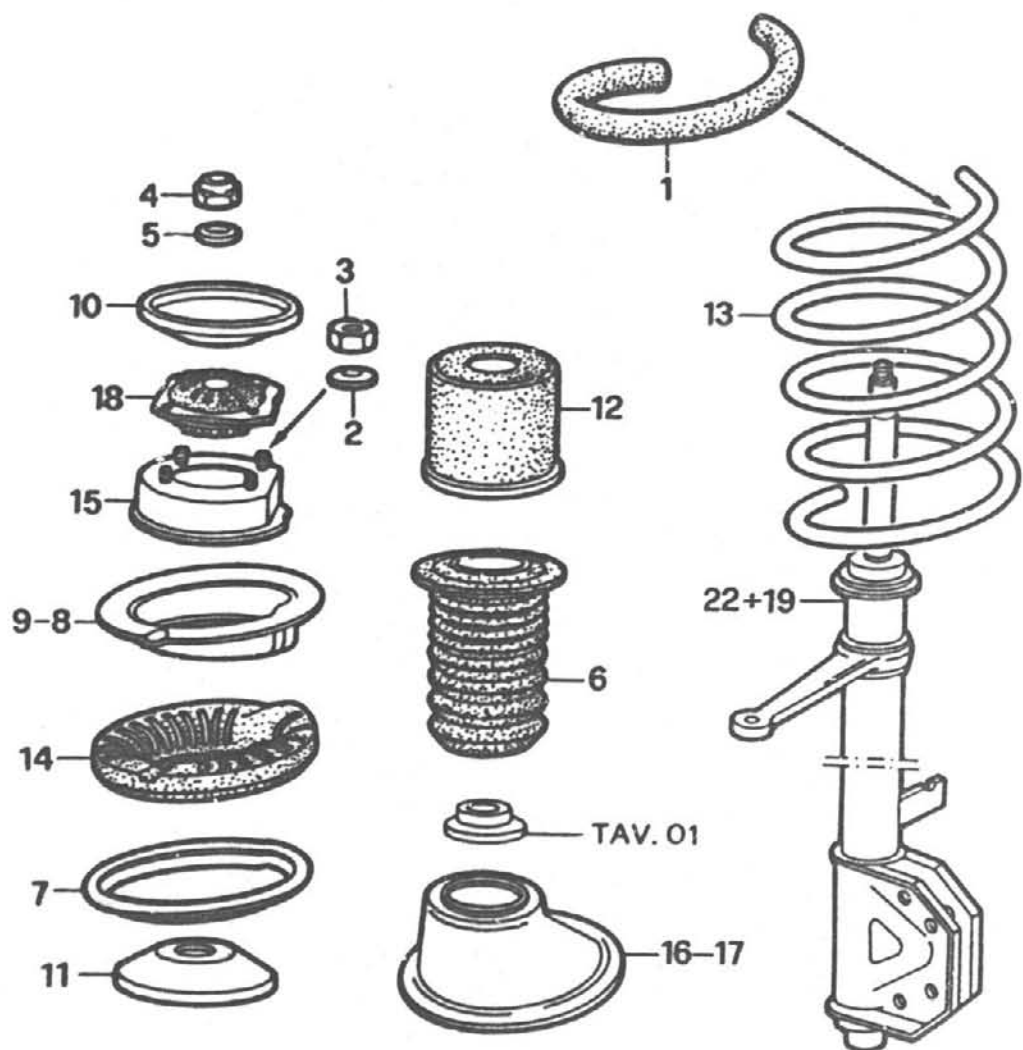

| pos. | TEILNUMMER | ref. | mg. | benennung |
|------|-------------------|------|-----|----------------|
| 1 | 00670 99742 | | | ROHR |
| 2 | 02100 81435 00 00 | | 8 | SCHEIBE |
| 3 | 00161 00811 | | 8 | MUTTER |
| 4 | 02125 92822 00 00 | | 1 | MUTTER |
| 5 | 00107 32411 | | 1 | SCHEIBE |
| 6 | 00605 01744 | | 2 | MANSCHETTE |
| 7 | 00605 01745 | | 2 | TELLER |
| 8 | 00605 01746 | ◆ | 1 | BEHAELTER |
| 9 | 00605 01747 | ◆ | 1 | BEHAELTER |
| 10 | 00605 01748 | | 2 | SCHEIBE |
| 11 | 00605 01432 | | 2 | SCHEIBE |
| 12 | 00605 01433 | | 2 | PUFFER |
| 13 | 00605 01407 | | 2 | FEDER |
| 14 | 00605 01408 | | 2 | SITZPOLSTER |
| 15 | 00605 01754 | | 2 | BEHAELTER |
| 16 | 00605 01443 | ◆ | 1 | TELLER |
| 17 | 00605 01444 | ◆ | 1 | TELLER |
| 18 | 00605 01445 | | 2 | ZWISCHENSTUECK |
| 19 | 00605 01426 | ◆ ▲ | 1 | STOSSDAEMPFER |
| 20 | 00605 40536 | ◆ ▲ | 1 | STOSSDAEMPFER |
| 21 | 00605 04733 | ◆ ● | 1 | STOSSDAEMPFER |
| 22 | 00605 04733 | ◆ ● | 1 | STOSSDAEMPFER |

◆ Rechts
◆ Links
▲ c.c. 1.3

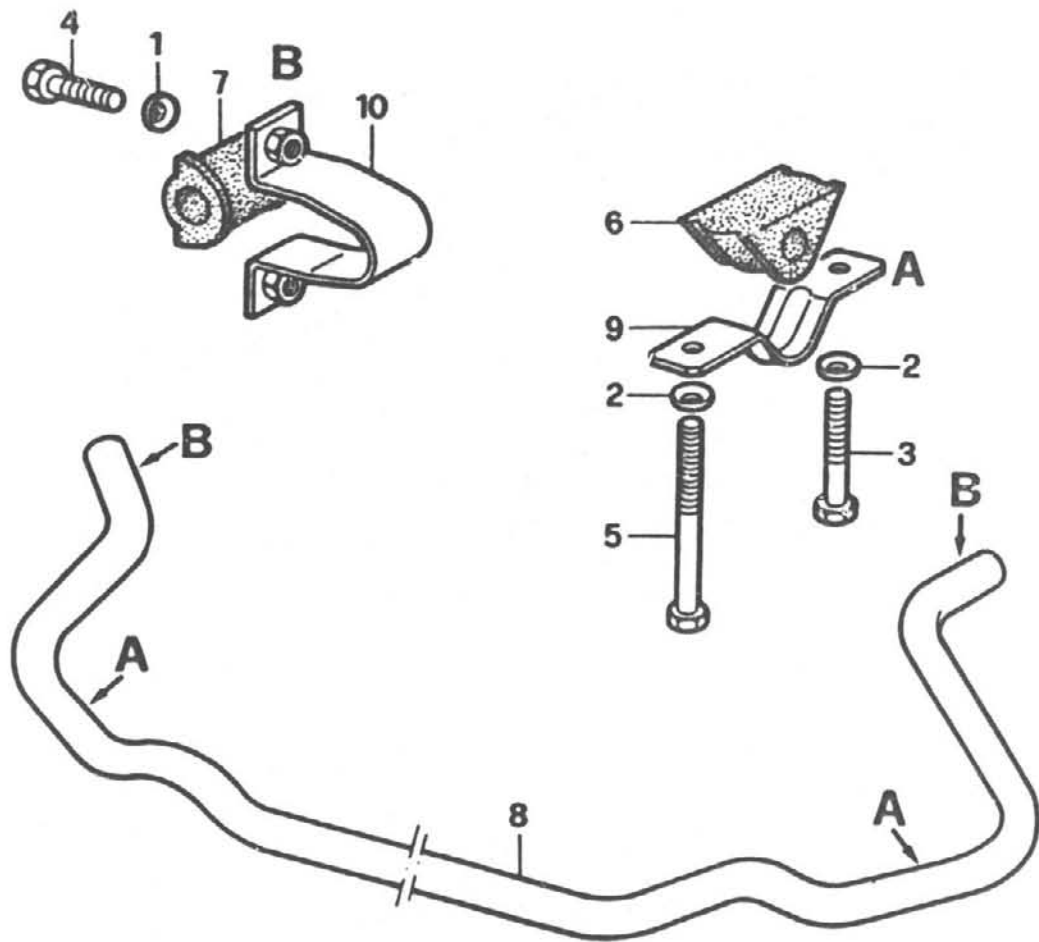

| pos. | TEILNUMMER | ref. | mg. benennung |
|------|-------------------|------|----------------|
| 1 | 02100 81434 00 00 | | 4 SCHEIBE |
| 2 | 00111 98779 | | 4 SCHEIBE |
| 3 | 00155 40421 | | 4 SCHRAUBE |
| 4 | 00161 35721 | | 4 SCHRAUBE |
| 5 | 00161 43921 | | 2 SCHRAUBE |
| 6 | 00605 05018 | | 2 GUMMITEIL |
| 7 | 00605 05020 | | 2 GUMMITEIL |
| 8 | 00605 05017 | | 1 STABILISATOR |
| 9 | 00605 24736 | | 2 WINKELSTUECK |
| 10 | 00605 05021 | | 2 WINKELSTUECK |

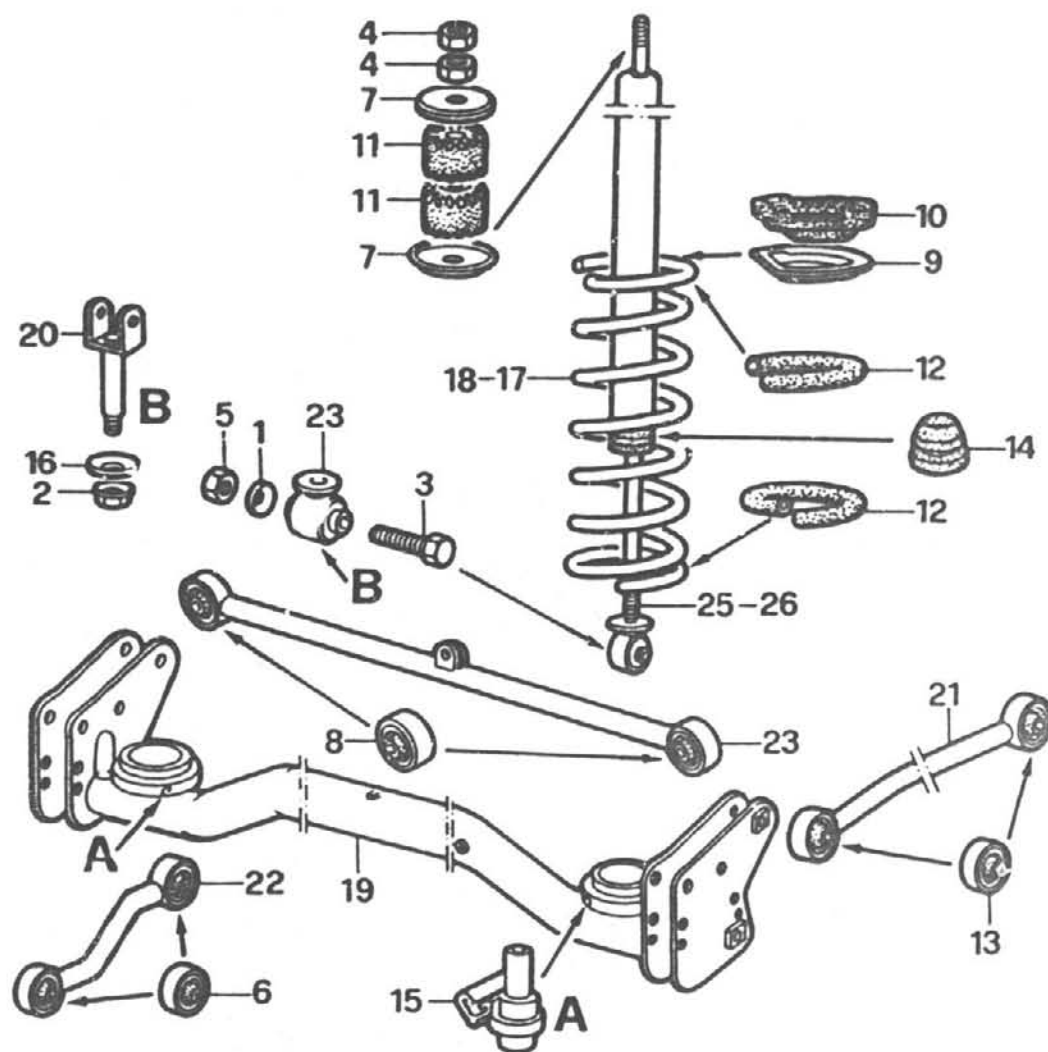

| pos. | TEILNUMMER | ref. | mg. | benennung |
|------|-------------------|------|-----|---------------|
| 1 | 02100 81434 00 00 | | 2 | SCHEIBE |
| 2 | 00140 58511 | | 2 | MUTTER |
| 3 | 00160 44421 | | 2 | SCHRAUBE |
| 4 | 00116 91311 | | 4 | MUTTER |
| 5 | 00161 00811 | | 2 | MUTTER |
| 6 | 00605 01911 | | 4 | BUECHSE |
| 7 | 00605 01913 | | 4 | TELLER |
| 8 | 00605 01915 | | 2 | BUECHSE |
| 9 | 00605 01916 | | 2 | TELLER |
| 10 | 00605 01917 | | 2 | DICHTUNG |
| 11 | 00605 01918 | | 4 | GUMMITEIL |
| 12 | 00605 01921 | | 4 | HUELLE |
| 13 | 00605 01922 | | 2 | SILENTBLOCK |
| 14 | 00605 01930 | | 2 | PUFFER |
| 15 | 12562 30000 00 00 | | 2 | BEFESTIGUNG |
| 16 | 00605 01567 | | 2 | SCHEIBE |
| 17 | 00605 01563 | ▲ | 2 | FEDER |
| 18 | 00605 05029 | ● | 2 | FEDER |
| 19 | 00605 01972 | | 1 | ACHSE |
| 20 | 00605 01934 | | 2 | FEDERKLAMMER |
| 21 | 00605 01936 | | 2 | STANGE |
| 22 | 00605 01937 | | 2 | STANGE |
| 23 | 00605 01938 | | 1 | STABILISATOR |
| 24 | 00605 01942 | | 2 | BEFESTIGUNG |
| 25 | 00605 04750 | ● | 2 | STOSSDAEMPFER |



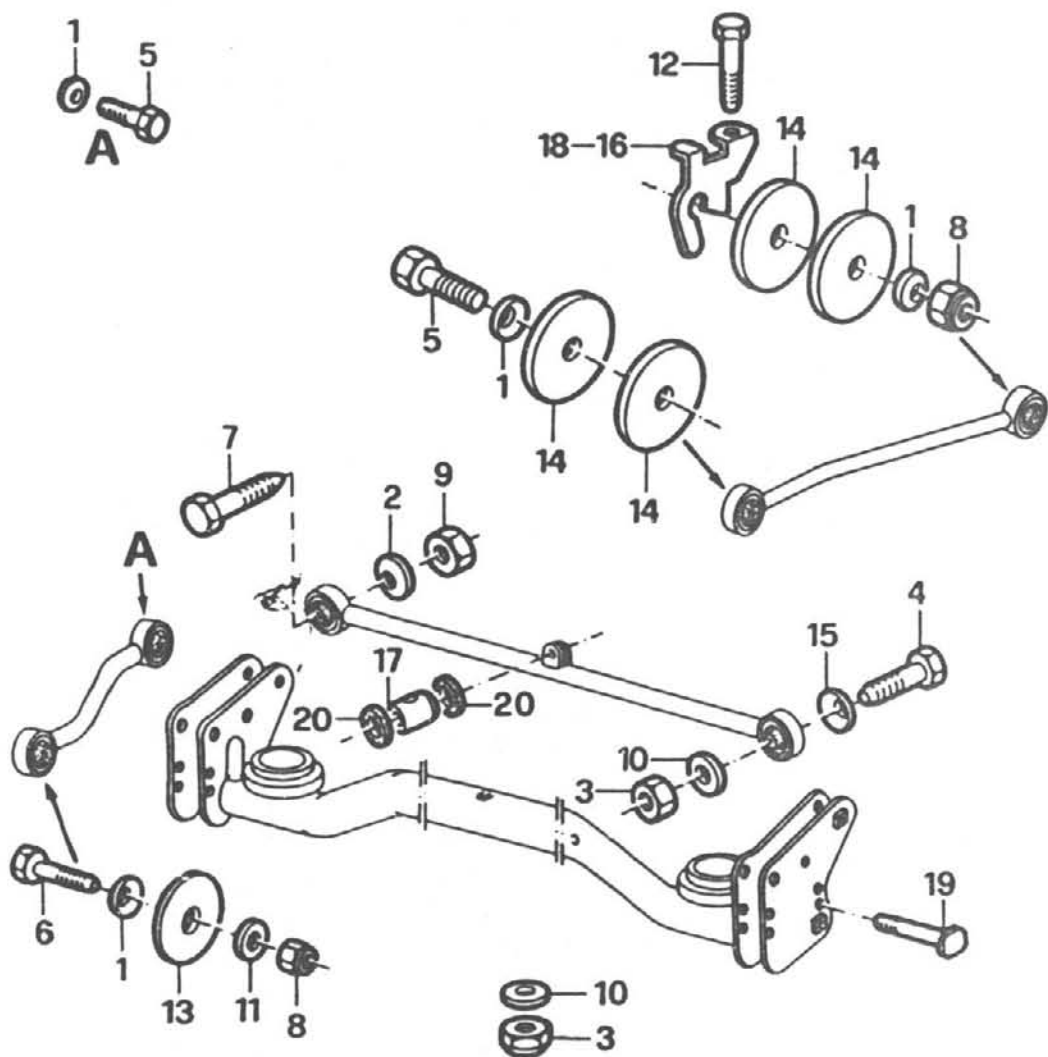

| pos. | TEILNUMMER | ref. | mg. benennung |
|------|------------------------|------|----------------|
| 1 | 02100 81437 00 00 | | 14 SCHEIBE |
| 2 | 02100 81440 00 00 | | 2 SCHEIBE |
| 3 | 00140 48811 | | 1 MUTTER |
| 4 | 00155 41921 | | 1 SCHRAUBE |
| 5 | 00158 88721 | | 4 SCHRAUBE |
| 6 | 00161 40521 | | 2 SCHRAUBE |
| 7 | 00161 42921 | | 2 SCHRAUBE |
| 8 | 00125 74511 | | 4 MUTTER |
| 9 | 02125 15042 00 00 | | 2 MUTTER |
| 10 | 00107 32517 | | 1 SCHEIBE |
| 11 | 00107 32411 | | 2 SCHEIBE |
| 12 | 00605 15595 | | 2 SCHRAUBE |
| 13 | 00605 01919 | | 2 SPRENGRING |
| 14 | 00605 01922 | | 8 SPRENGRING |
| 15 | 00605 01925 | | 2 SCHEIBE |
| 16 | 00607 38470 | ↗ | 2 WINKELSTUECK |
| 17 | 00605 01571 | | 1 BOLZEN |
| 18 | 00605 01670 | ↖ | 1 WINKELSTUECK |
| 19 | 00605 01580 | | 8 SCHRAUBE |
| 20 | 00605 01572 | | 2 SPRENGRING |

O10

SPRINT
Ed. 87
Meccanica
1-1989

TAV. 31.20

c.c. 32

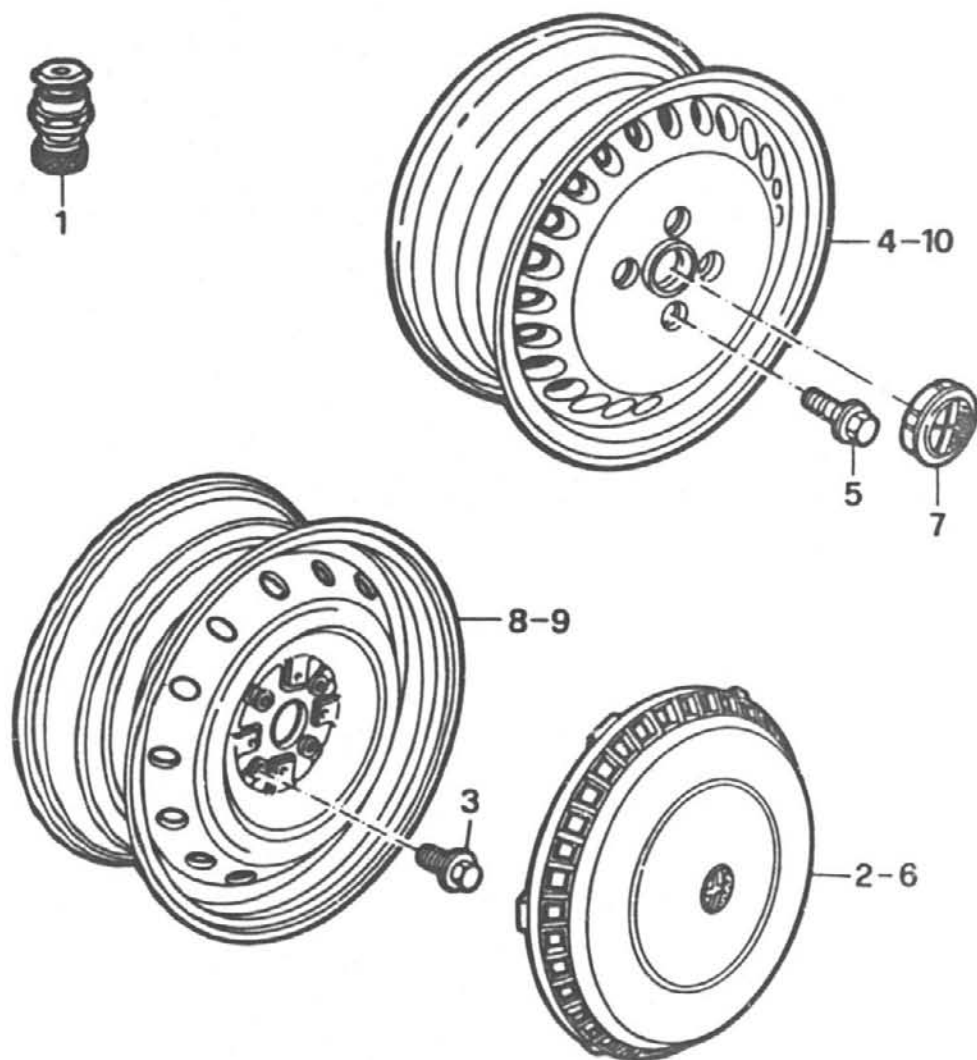

| pos. | TEILNUMMER | ref. | mg. benennung |
|------|-------------|------|---------------|
| 1 | 02400 56001 | | 5 VENTIL |
| 2 | 00605 17720 | ▲ | 4 NABENKAPPE |
| 3 | 00605 01597 | | 16 SCHRAUBE |
| 4 | 00965 85249 | ▲ | 5 RAD |
| 5 | 00605 01598 | | 16 SCHRAUBE |
| 6 | 00605 33057 | ● | 4 RADKAPPE |
| 7 | 00605 01615 | | 5 RADKAPPE |
| 8 | 00605 37495 | ▲ | 5 RAD |
| 9 | 00605 15006 | ● | 5 RAD |
| 10 | 00605 04975 | ● | 5 FELGE |

▲ c.c. 1.3
● c.c. 1.7

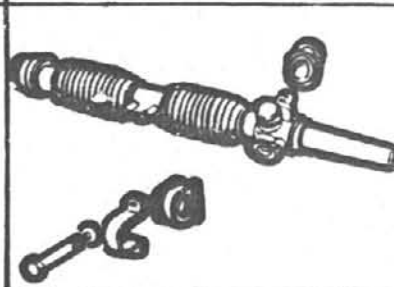
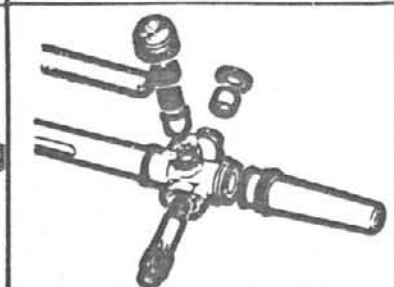
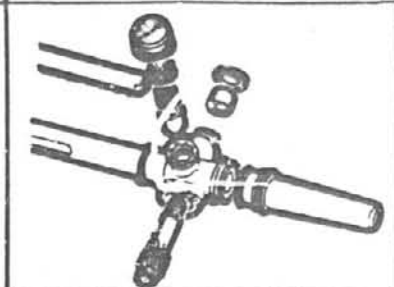
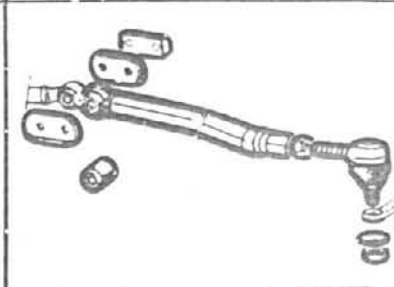
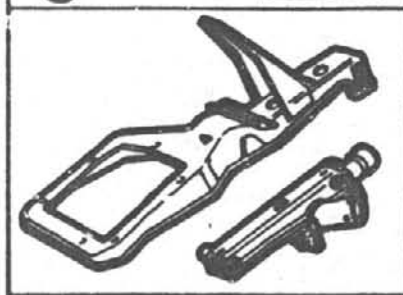
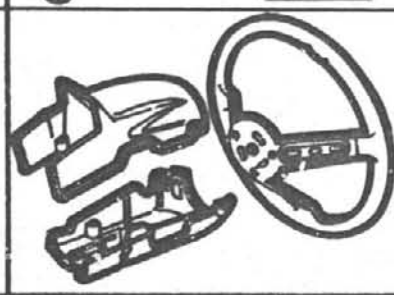
| | | | | | |
|--|---|--|---|---|---|
| SPRINT 87 MECCANICA | 9-1987 | 1 TAV 32.05 | 2 TAV 32.06 | 3 TAV 32.06 | 4 TAV 32.25 |
| <h1 style="text-align: center;">P</h1> |  |  |  |  | |
| | 5 TAV 32.11 | 6 TAV 32.10 | 7 TAV | 8 TAV | 9 TAV |
|  |  | | | | |
| 10 TAV | 11 TAV | 12 TAV | 13 TAV | 14 TAV | |
| | | | | | |
| 15 TAV | 16 TAV | 17 TAV | 18 TAV | 19 TAV | |
| | | | | | |

P₁

SPRINT
Ed. 87
Meccanica
1-1989

TAV. 32.05

c.c. 32

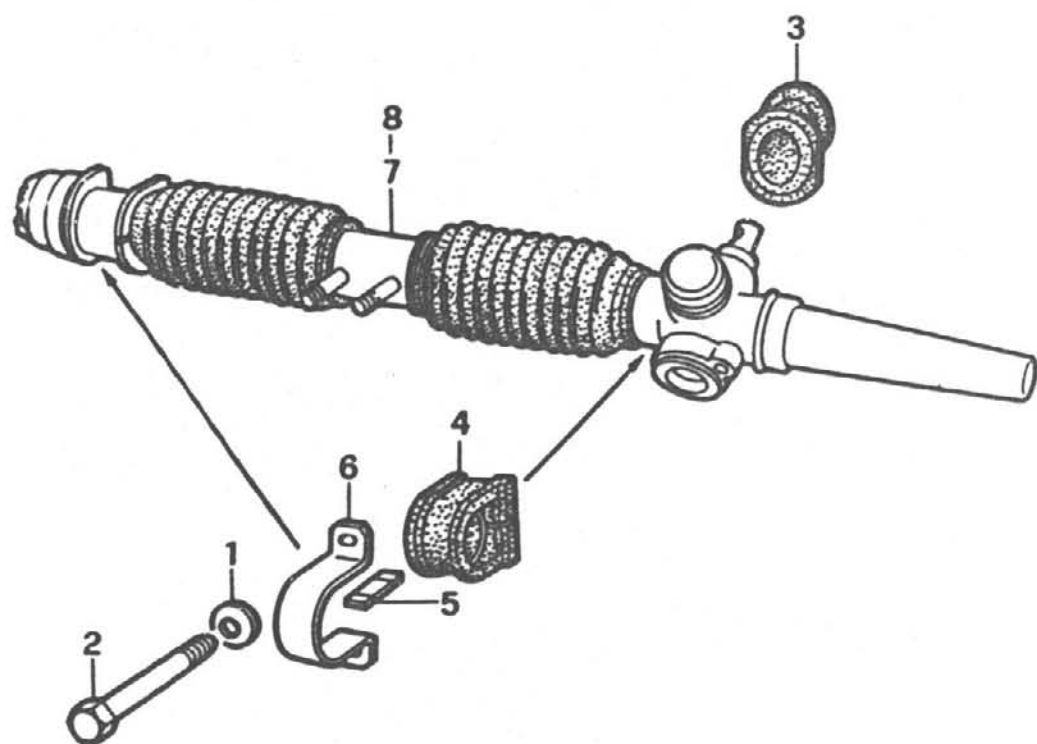

| pos. | TEILNUMMER | ref. | mg. | benennung |
|------|-------------------|------|-----|----------------|
| 1 | 02100 81434 00 00 | | 4 | SCHEIBE |
| 2 | 00160 44321 | | 4 | SCHRAUBE |
| 3 | 00605 01094 | | 1 | RING |
| 4 | 00605 02779 | | 2 | ZWISCHENSTUECK |
| 5 | 00605 01474 | | 2 | ZUNGE |
| 6 | 00605 01475 | | 2 | HALTER |
| 7 | 00607 44060 | ⊖ | 1 | LENKGEHAEUSE |
| 8 | 00607 44061 | ⊚ | 1 | LENKGEHAEUSE |

⊖ G.S.
⊚ G.D.

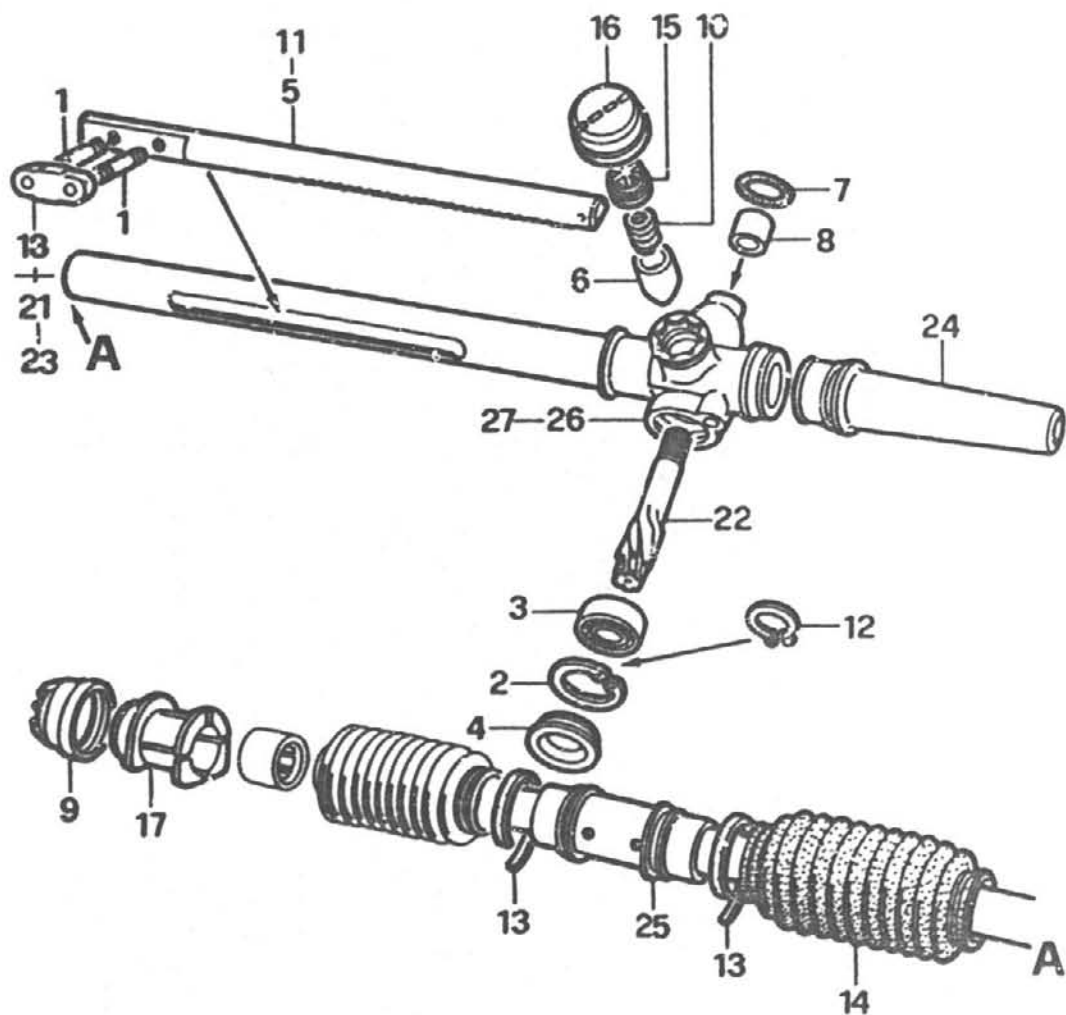

| pos. | TEILNUMMER | ref. | ing. benennung |
|------|-------------|-------|----------------|
| 1 | 02100 08119 | | 2 STEHBOLZEN |
| 2 | 00110 59970 | | 1 RING |
| 3 | 00605 02766 | | 1 LAGER |
| 4 | 00605 02767 | | 1 KAPPE |
| 5 | 00605 02770 | ● | 1 ZAHNSTANGE |
| 6 | 00605 02772 | | 1 KOLBEN |
| 7 | 00605 02774 | | 1 DICHTRING |
| 9 | 00605 02775 | | 1 BUECHSE |
| 9 | 00605 02776 | | 1 KAPPE |
| 10 | 00605 02777 | | 1 FEDER |
| 11 | 00605 15705 | ☑ | 1 ZAHNSTANGE |
| 12 | 00605 02706 | | 1 ARRETIERRING |
| 13 | 00605 02778 | | 4 SCHELLE |
| 14 | 00605 02781 | | 2 MANSCHETTE |
| 15 | 00605 02784 | | 1 SCHRAUBE |
| 16 | 00605 02785 | | 1 KAPPE |
| 17 | 00605 02786 | | 1 LAGERUNG |
| 18 | 00605 02792 | BI | 1 BREMSBELAG |
| 19 | 00605 02793 | GI | 1 BREMSBELAG |
| 20 | 00605 02794 | RO | 1 BREMSBELAG |
| 21 | 00605 02795 | YE | 1 BREMSBELAG |
| 22 | 00605 02798 | | 1 KEGELRAD |
| 23 | 00605 02799 | BL NE | 1 BREMSBELAG |
| 24 | 00505 01478 | | 1 KAPPE |
| 25 | 00605 028U1 | | 1 SCMALTMUFFE |



P₃

SPRINT
Ed. 87
Meccanica

1-1989

TAV. 32.06

c.c. 32

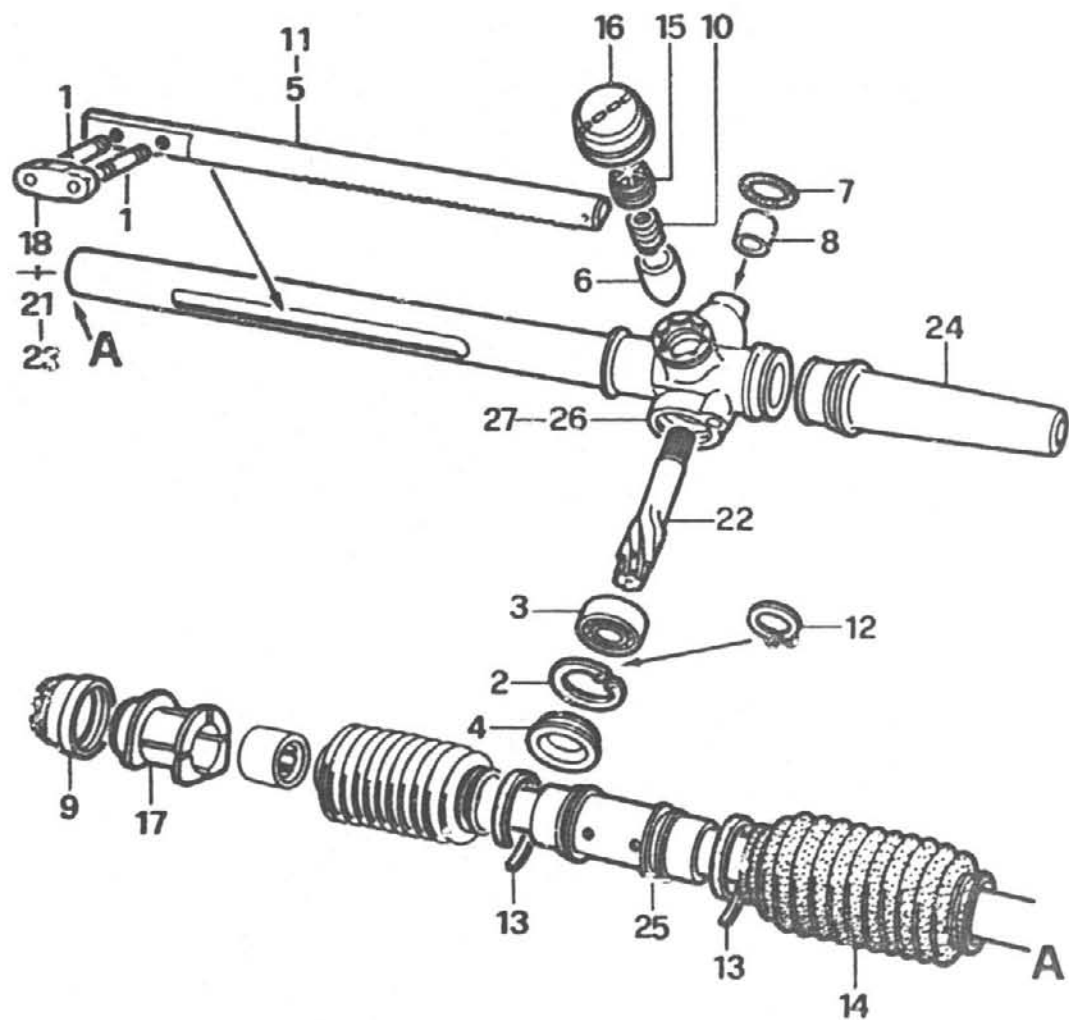

| pos. | TEILNUMMER | ref. | mg. | benennung |
|------|-------------|------|-----|--------------|
| 26 | 00607 50629 | ● | 1 | LENKGEHAEUSE |
| 27 | 00607 50630 | ■ | 1 | LENKGEHAEUSE |

● G.S.
■ G.D.

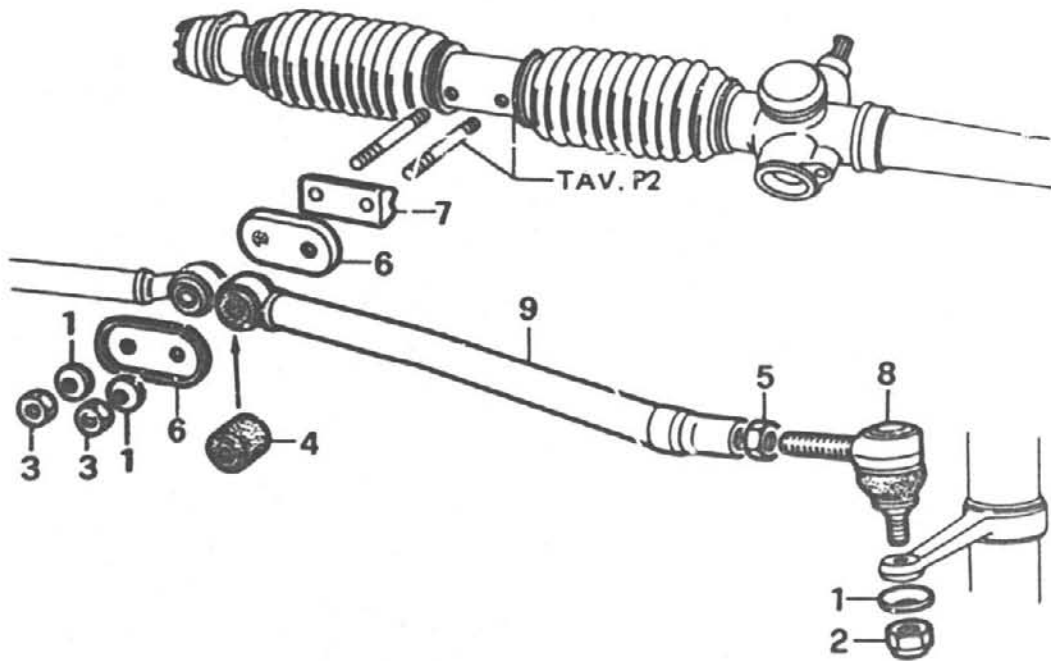

| pos. | TEILNUMMER | ref. | mg. benennung |
|------|-------------------|------|---------------|
| 1 | 02100 81437 00 00 | 4 | SCHEIBE |
| 2 | 00161 12111 | 1 | MUTTER |
| 3 | 00121 64721 | 2 | MUTTER |
| 4 | 00605 02771 | 2 | BUECHSE |
| 5 | 00605 02773 | 2 | MUTTER |
| 6 | 00605 02790 | 2 | PLAETTCHEN |
| 7 | 00605 02791 | 1 | ABSTANDSTUECK |
| 8 | 00605 01531 | 1 | GELENK |
| 9 | 00605 01536 | 1 | STANGE |

P₅

SPRINT
Ed. 87
Meccanica
1-1989

TAV. 32.11

c.c. 32

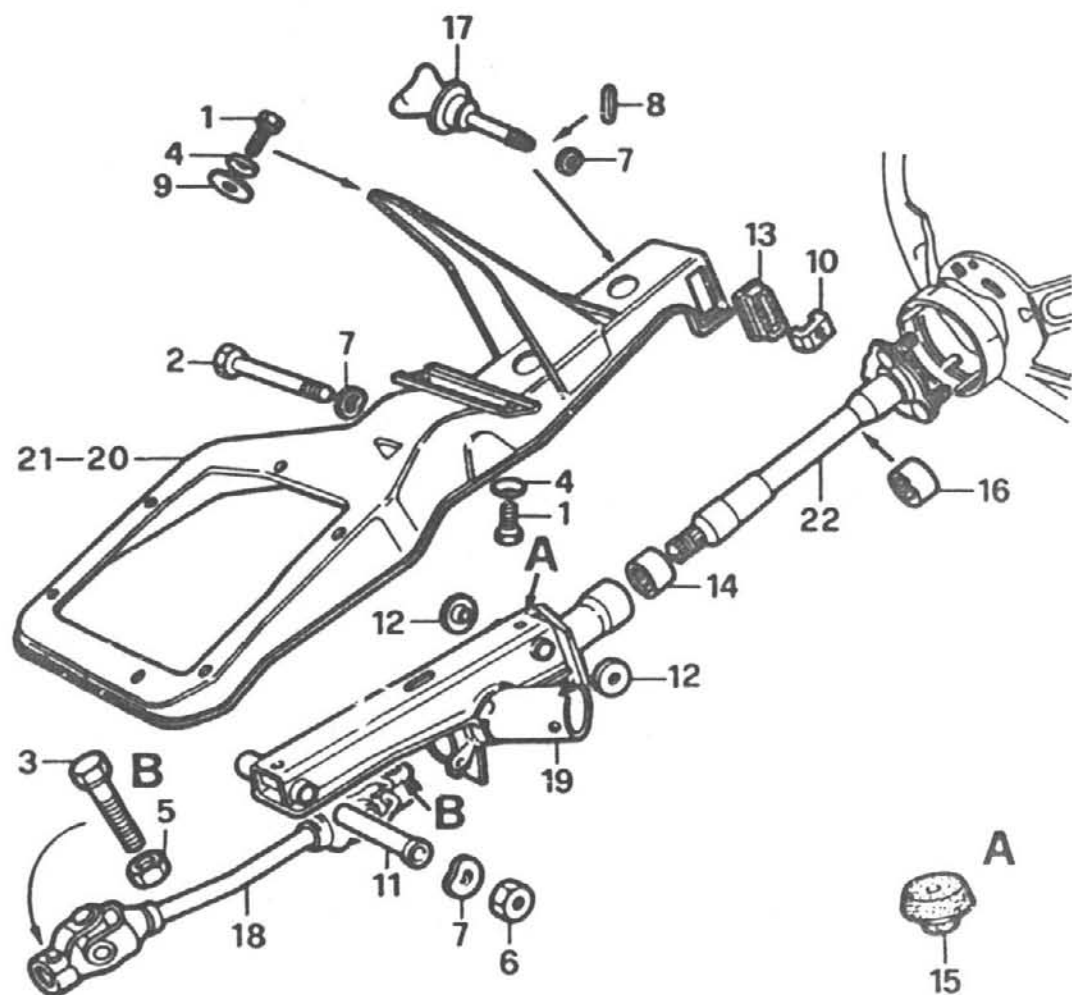

| pos. | TEILNUMMER | ref. | mg. | benennung |
|------|-------------|------|-----|-------------------|
| 1 | 00109 02123 | | 1 | SCHRAUBE |
| 2 | 00161 37323 | | 1 | SCHRAUBE |
| 3 | 00160 43933 | | 2 | SCHRAUBE |
| 4 | 00111 93779 | | 1 | SCHEIBE |
| 5 | 00140 48221 | | 2 | MUTTER |
| 6 | 00161 00811 | | 1 | MUTTER |
| 7 | 00126 01370 | | 6 | SCHEIBE |
| 8 | 00141 61570 | | 1 | SPLINT |
| 9 | 00605 15461 | | 1 | SCHEIBE |
| 10 | 00605 15592 | | 1 | BREMSBELAG |
| 11 | 00605 15708 | | 1 | ABSTANDSTUECK |
| 12 | 00605 17428 | | 2 | SCHEIBE |
| 13 | 00605 17441 | | 1 | BREMSBELAG |
| 14 | 00605 01489 | | 1 | BUECHSE ϕ 19 |
| 15 | 00607 29628 | | 1 | PUFFER |
| 16 | 00605 36032 | | 1 | BUECHSE ϕ 24 |
| 17 | 00605 36160 | | 1 | KNOPF |
| 18 | 00605 36278 | | 1 | LENKSPINDELROHR |
| 19 | 00605 36855 | | 1 | LAGERUNG |
| 20 | 00605 36999 | ⊖ | 1 | LAGERUNG |
| 21 | 00605 37000 | ⊠ | 1 | LAGERUNG |
| 22 | 00605 37210 | | 1 | LENKSPINDELROHR |

⊖ G.S.
⊠ G.D.

P₆

SPRINT
Ed. 87
Meccanica

1-1989

TAV. 32.10

c.c. 32

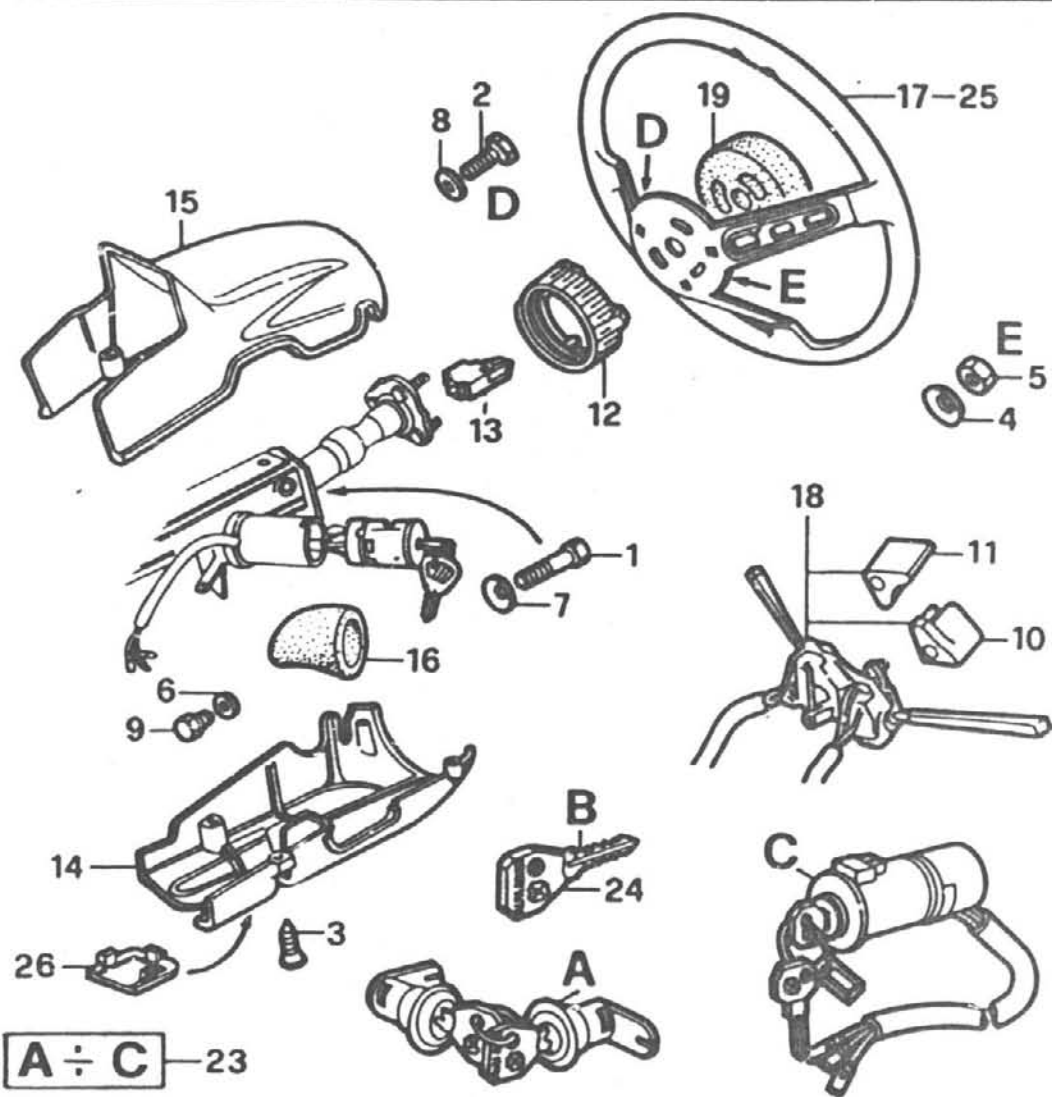

| pos. | TEILNUMMER | ref. | mg. benennung |
|------|-------------------|-------------------------------------|-------------------|
| 1 | 00109 78423 | | 1 SCHRAUBE |
| 2 | 02100 16339 00 00 | | 2 SCHRAUBE |
| 3 | 00156 44507 | | 4 SCHRAUBE |
| 4 | 02100 81435 00 00 | | 3 SCHEIBE |
| 5 | 00161 00811 | | 3 MUTTER |
| 6 | 02140 16649 00 00 | | 1 SCHEIBE |
| 7 | 00111 95470 | | 1 SCHEIBE |
| 8 | 00135 77511 | | 2 SCHEIBE |
| 9 | 00607 09759 | | 1 SCHRAUBE |
| 10 | 00607 09773 | | 1 KLAUE |
| 11 | 00607 09774 | | 1 KLAUE |
| 12 | 00605 18436 | | 1 RING |
| 13 | 00605 23650 | | 1 KLAUE |
| 14 | 00605 23733 | | 1 GEHAEUSEHAELFTE |
| 15 | 00605 23734 | | 1 GEHAEUSEHAELFTE |
| 16 | 00605 23753 | | 1 ABDECKUNG |
| 17 | 00605 36290 | | 1 LENKRAD |
| 18 | 00605 36615 | | 1 LICHTSCHALTER |
| 19 | 00605 36862 | | 1 NABE |
| 23 | 00605 37494 | | 1 SCHLOESSATZ |
| 24 | 11646 88021 00 00 | | SCHUESSELROHLING |
| 25 | 00605 36849 | <input checked="" type="checkbox"/> | 1 LENKRAD |
| 26 | 00605 25488 | <input checked="" type="checkbox"/> | 1 STOPFEN |

I.E.

1-1989

1

TAV 21.00

2

TAV 21.00

3

TAV 21.00/3

4

TAV 21.00/5

Q

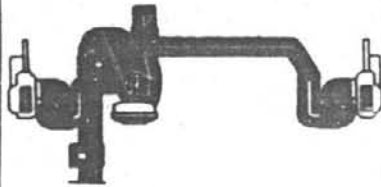

A

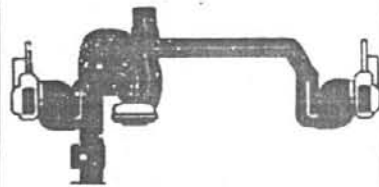

A

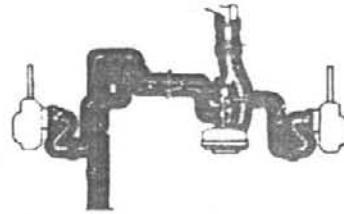

A G.D.

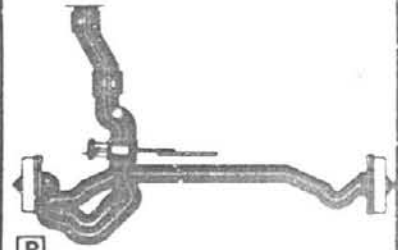

P

5

TAV 21.02

6

TAV 21.10

7

TAV 21.12

8

TAV

9

TAV 21.50/1

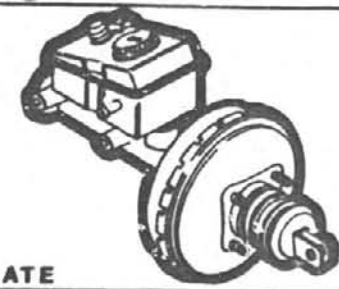
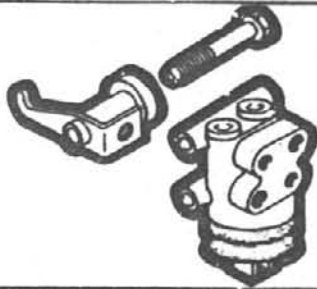

ATE

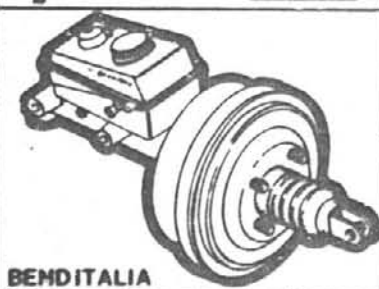

BENDITALIA

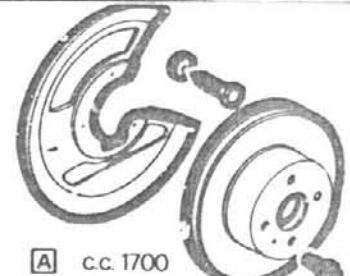

A c.c. 1700

10

TAV 21.50

11

TAV 21.52/1

12

TAV 21.51

13

TAV 21.52

14

TAV 21.52/3

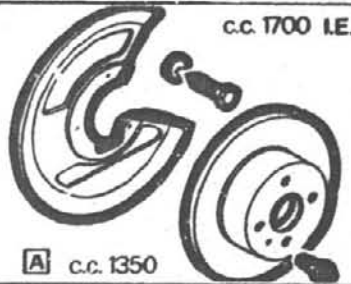

c.c. 1700 I.E.

A c.c. 1350

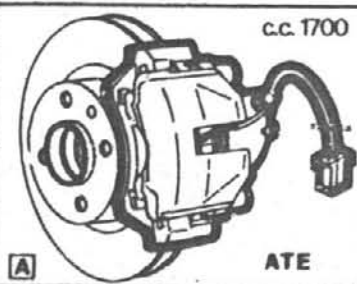

c.c. 1700

A

ATE

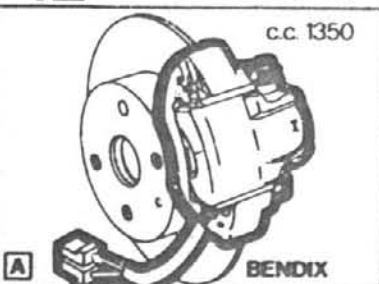

c.c. 1350

A

BENDIX

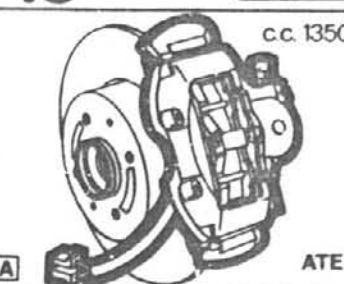

c.c. 1350

A

ATE

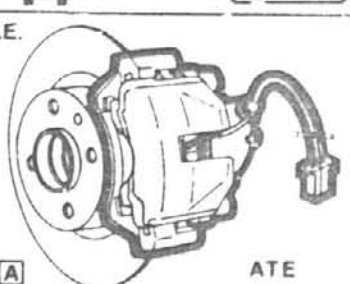

I.E.

A

ATE

15

TAV 21.60

16

TAV 21.61

17

TAV 21.61/5

18

TAV

19

TAV

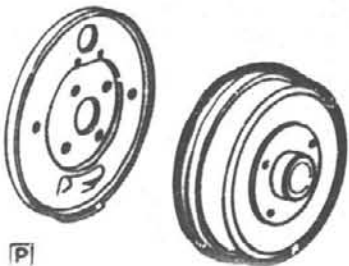

P



P

BENDIX



I.E.

P

BENDIX

Q1

SPRINT
Ed. 67
Meccanica
1-1989

G.S. - A

TAV. 21.00

c.c. 32

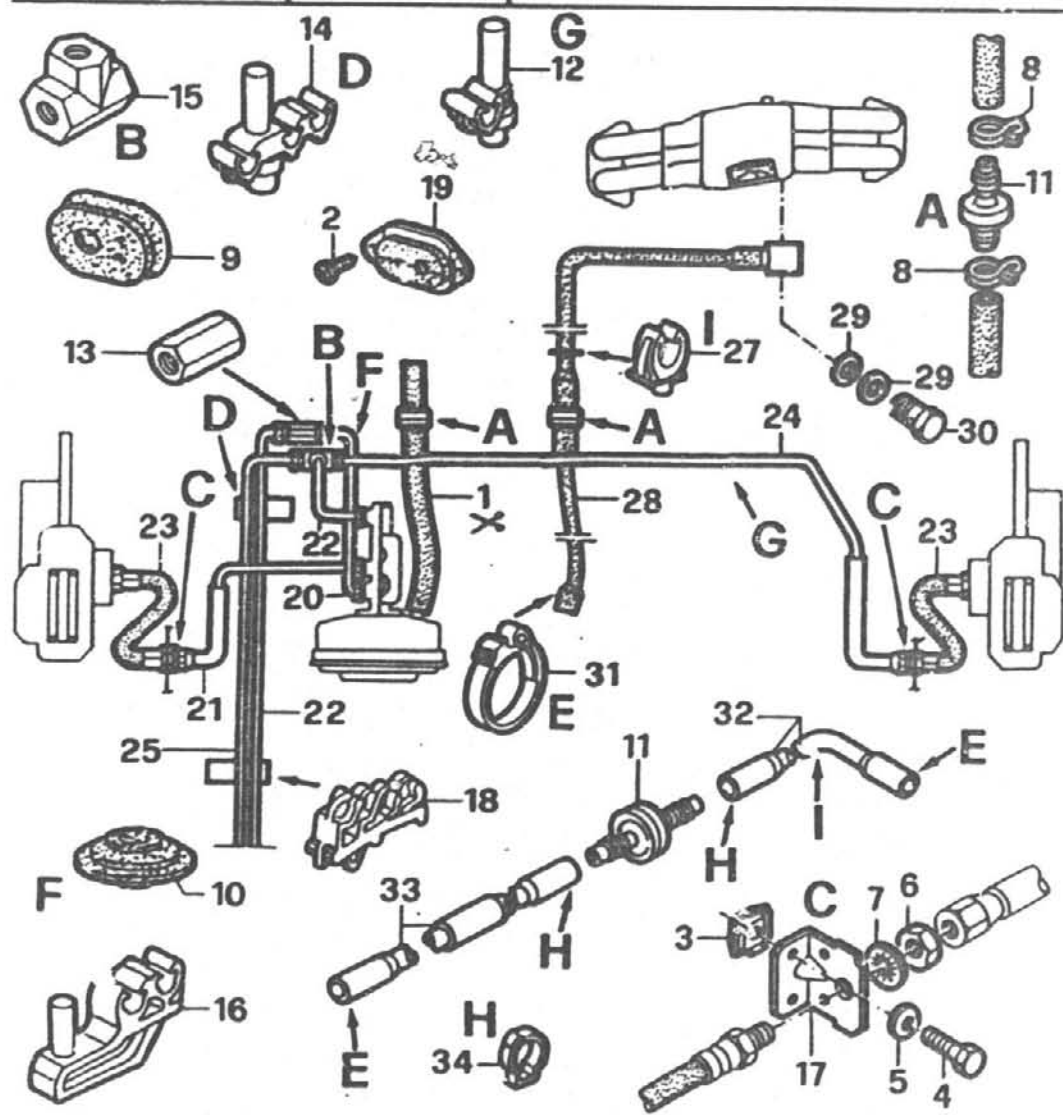

| pos. | TEILNUMMER | ref. | mg. benennung |
|------|-------------------|------|----------------|
| 1 | 00670 99984 | | ROHR |
| 2 | 02100 16340 00 00 | 2 | SCHRAUBE |
| 3 | 00146 48390 | 2 | MUTTER |
| 4 | 00109 02121 | 1 | SCHRAUBE |
| 5 | 02105 81408 00 00 | 1 | SCHEIBE |
| 6 | 00116 91321 | 1 | MUTTER |
| 7 | 00126 05679 | 2 | SCHEIBE |
| 8 | 00605 01337 | 2 | SCHLAUCHBINDER |
| 9 | 00605 15681 | 1 | GUMMITEIL |
| 10 | 00605 15684 | 1 | GUMMITEIL |
| 11 | 00605 01339 | 1 | VERTEILER |
| 12 | 12562 36000 00 00 | 3 | HALTER |
| 13 | 12590 70000 00 00 | 1 | SCALTMUFFE |
| 14 | 00605 01704 | 1 | HALTER |
| 15 | 00605 01705 | 1 | VERTEILER |
| 16 | 00605 01706 | 1 | HALTER |
| 17 | 00605 24483 | 1 | HALTER |
| 18 | 00605 03819 | 6 | KLAMMER |
| 19 | 00605 36406 | 1 | GUMMITEIL |
| 20 | 00605 37770 | 1 | ROHR |
| 21 | 00605 37771 | 1 | ROHR |
| 22 | 00605 37772 | 1 | ROHR |
| 23 | 00605 01727 | 2 | SCHLAUCH |
| 24 | 00605 01730 | 1 | ROHR |
| 25 | 00605 01731 | 1 | ROHR |



Q2

SPRINT
Ed. 87
Meccanica
1-1989

G.S. - A

TAV. 21.00

c.c. 32

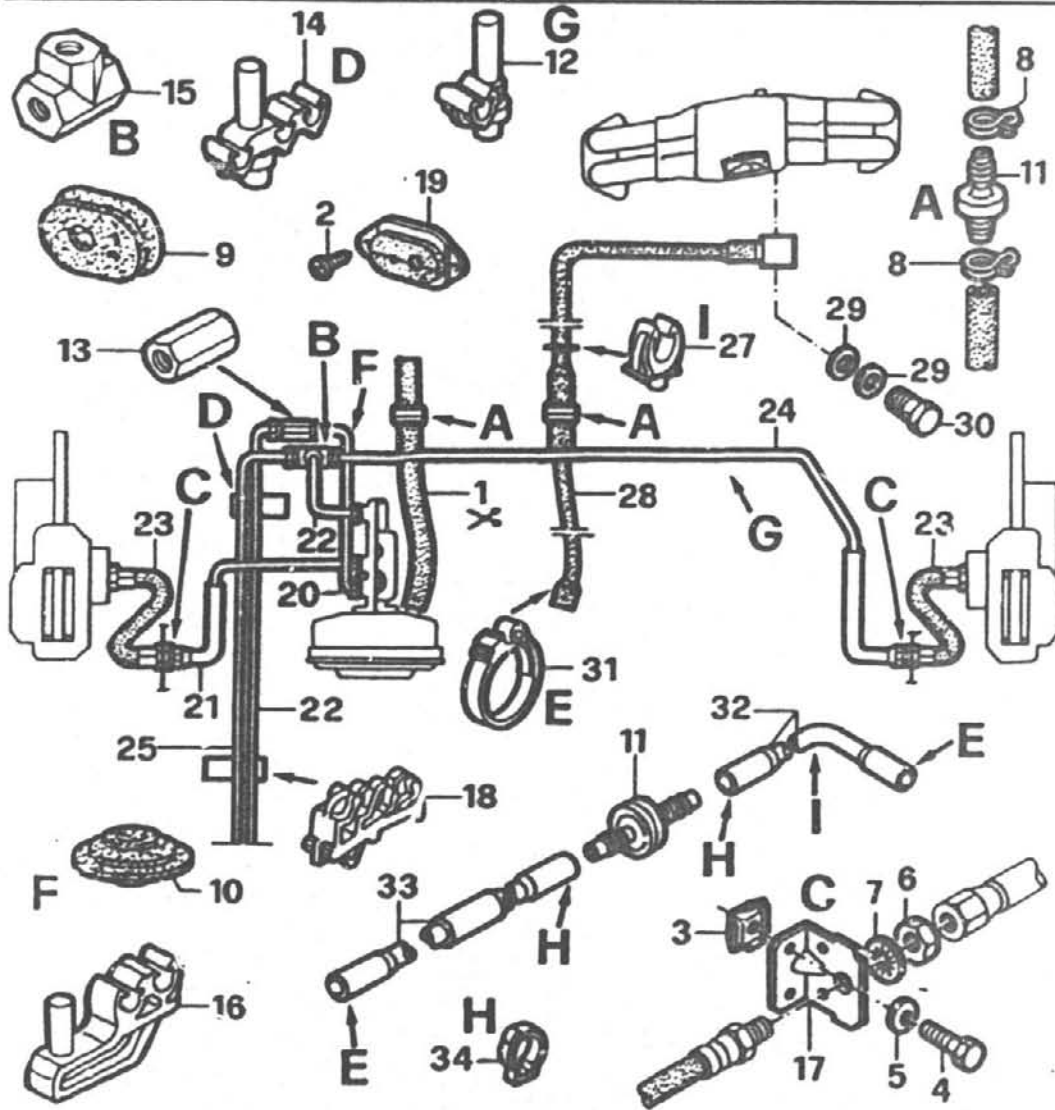

| pos. | TEILNUMMER | ref. | mg. | benennung | ↑ |
|------|-------------|-------------------------------------|-----|-----------|---|
| 26 | 00605 01732 | | 1 | ROHR | |
| 27 | 00605 14976 | | 4 | KLAMMER | |
| 28 | 00605 38347 | <input checked="" type="checkbox"/> | 1 | ROHR | |
| 29 | 00605 14975 | <input checked="" type="checkbox"/> | 2 | DICHTUNG | |
| 30 | 00101 84411 | <input checked="" type="checkbox"/> | 1 | STUTZEN | |
| 31 | 00131 00390 | | 3 | SCELLE | |
| 32 | 00605 42456 | | 1 | ROHR | |
| 33 | 00605 42457 | | 1 | ROHR | |
| 34 | 00605 42454 | | 2 | SCELLE | |

I.E.

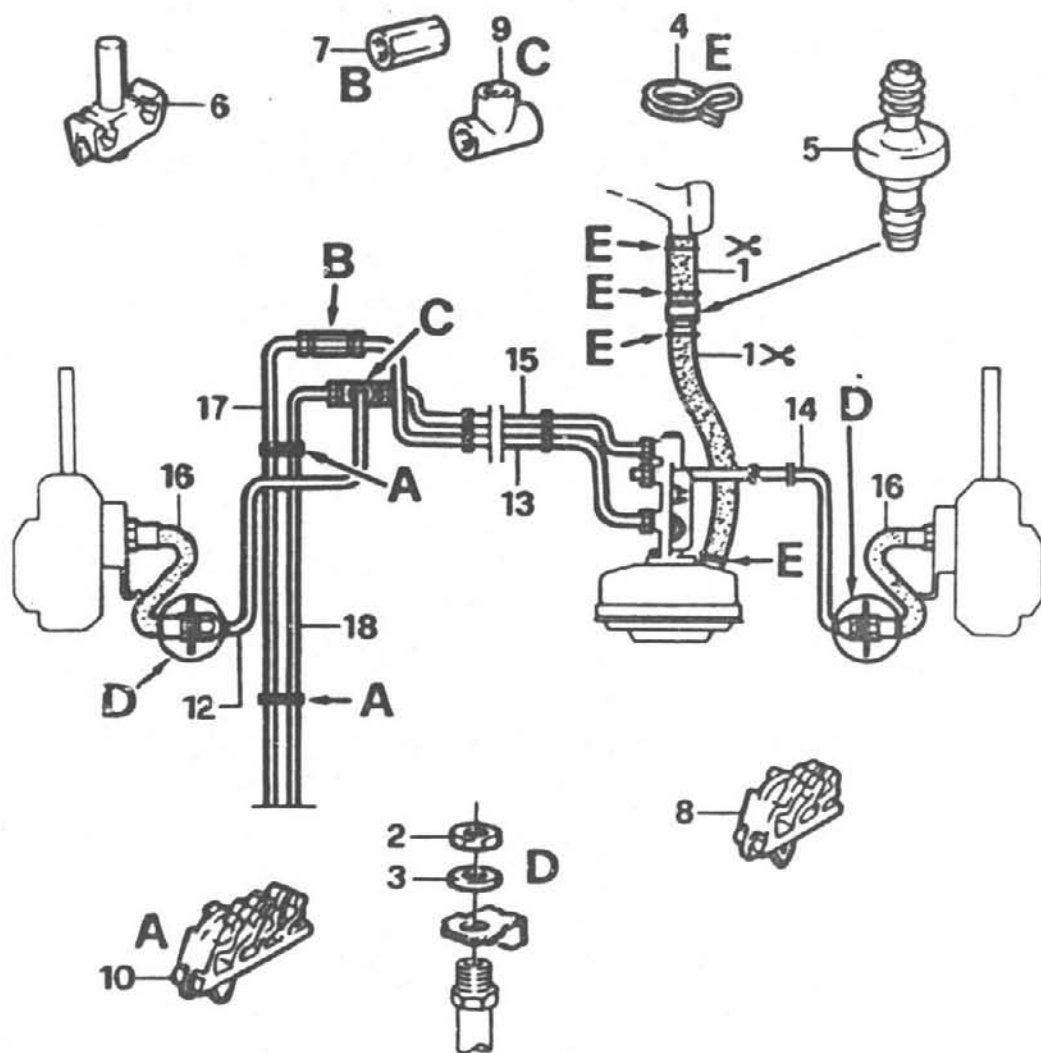

| pos. | TEILNUMMER | ref. | mg. benennung |
|------|-------------------|------|-----------------|
| 1 | 00670 99984 | | ROHR |
| 2 | 00116 91321 | 1 | MUTTER |
| 3 | 00126 05679 | 2 | SCHEIBE |
| 4 | 00605 01337 | 2 | SCHLAUCHBINDER |
| 5 | 00605 01339 | 1 | VERTEILER |
| 6 | 00605 03398 | 2 | ROHRBEFESTIGUNG |
| 7 | 12590 70000 00 00 | 1 | VERTEILER |
| 8 | 00605 01704 | 1 | HALTER |
| 9 | 00605 01705 | 1 | VERTEILER |
| 10 | 00605 03819 | 6 | ROHRBEFESTIGUNG |
| 12 | 00605 37769 | 1 | ROHR |
| 13 | 00605 37773 | 1 | ROHR |
| 14 | 00605 37774 | 1 | ROHR |
| 15 | 00605 37775 | 1 | ROHR |
| 16 | 00605 01727 | 2 | SEIL |
| 17 | 00605 01731 | 1 | ROHR |
| 18 | 00605 01732 | 1 | ROHR |

Q4

SPRINT
Ed. 87
Meccanica
1-1989

P

TAV. 21.00/5

c.c. 32

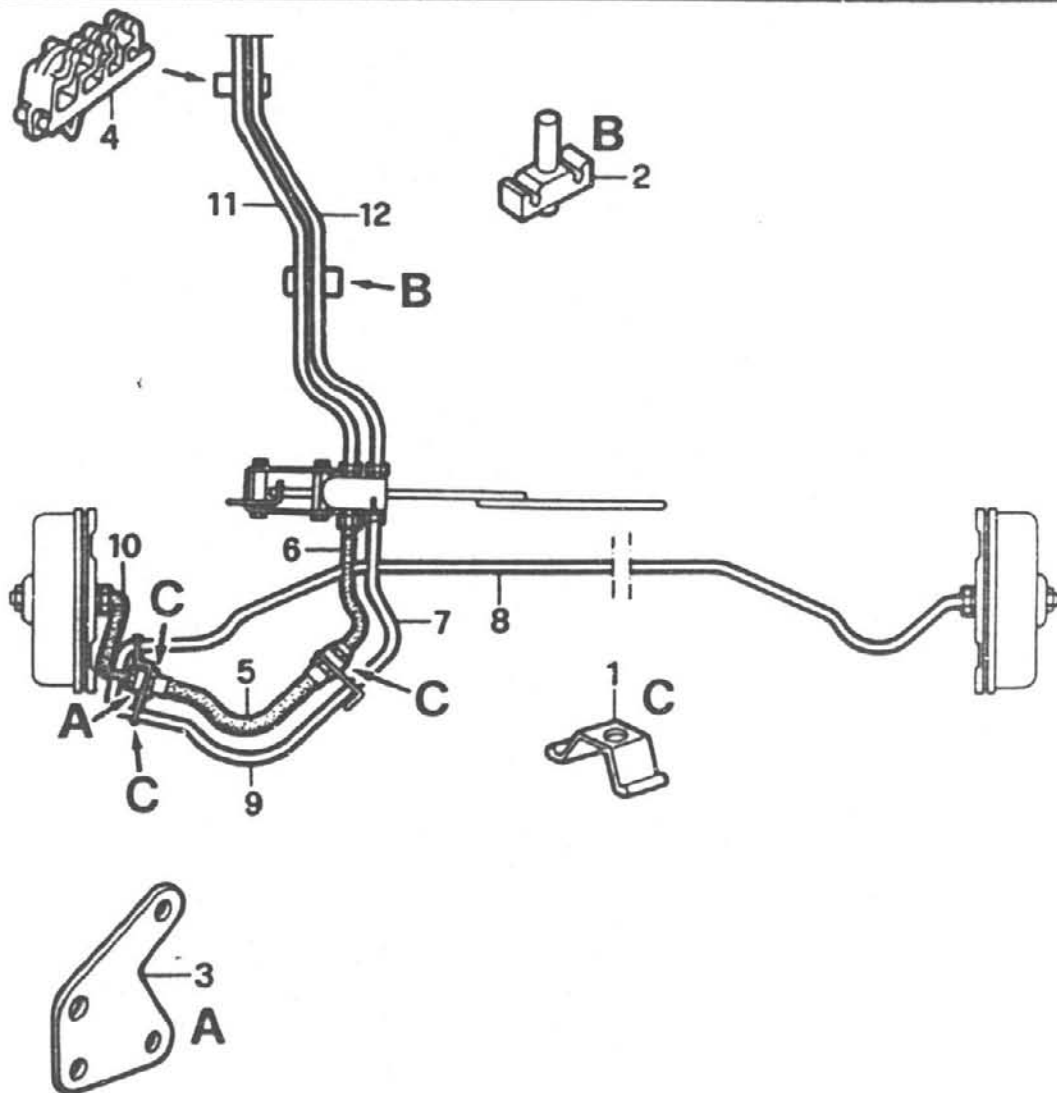

| pos. | TEILNUMMER | ref. | mg. benennung |
|------|-------------|------|-------------------|
| 1 | 00605 01335 | | 1 FEDER |
| 2 | 00605 01702 | | 2 ROHRBEFESTIGUNG |
| 3 | 00605 01711 | | 2 HALTER |
| 4 | 00605 03819 | | 6 KLAMMER |
| 5 | 00605 01721 | | 1 SCHLAUCH |
| 6 | 00605 01718 | | 1 ROHR |
| 7 | 00605 01719 | | 1 ROHR |
| 8 | 00605 01720 | | 1 ROHR |
| 9 | 00605 01721 | | 1 SCHLAUCH |
| 10 | 00605 01723 | | 1 ROHR |
| 11 | 00605 01731 | | 1 ROHR |
| 12 | 00605 01732 | | 1 ROHR |

Q5

SPRINT
Ed. 87
Meccanica
1-1989

TAV. 21.02

c.c. 32

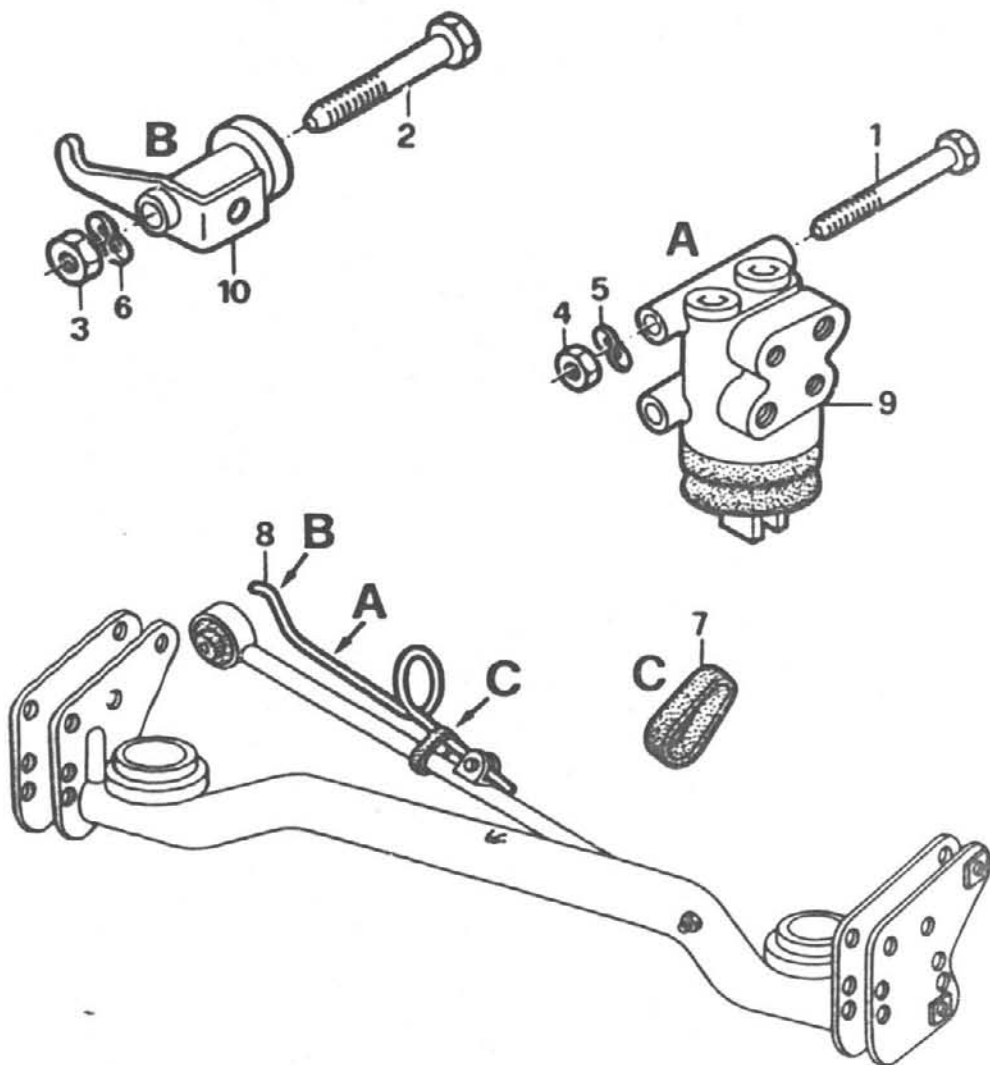

| pos. | TEILNUMMER | ref. | mg. benennung |
|------|-------------|------|----------------|
| 1 | 00161 36821 | | 2 SCHRAUBE |
| 2 | 00161 39821 | | 1 SCHRAUBE |
| 3 | 00121 64711 | | 1 M'JTTER |
| 4 | 00161 00811 | | 2 MUTTER |
| 5 | 00126 01379 | | 2 SCHEIBE |
| 6 | 00126 01479 | | 1 SCHEIBE |
| 7 | 00605 01336 | | 1 RING |
| 8 | 00605 01733 | | 1 FEDER |
| 9 | 00605 01737 | | 1 REGLERGRUPPE |
| 10 | 00605 01738 | | 1 WINKELSTUECK |

Q6

SPRINT
Ed. 87
Meccanica

1-1989

ATE

TAV. 21.10

c.c. 32

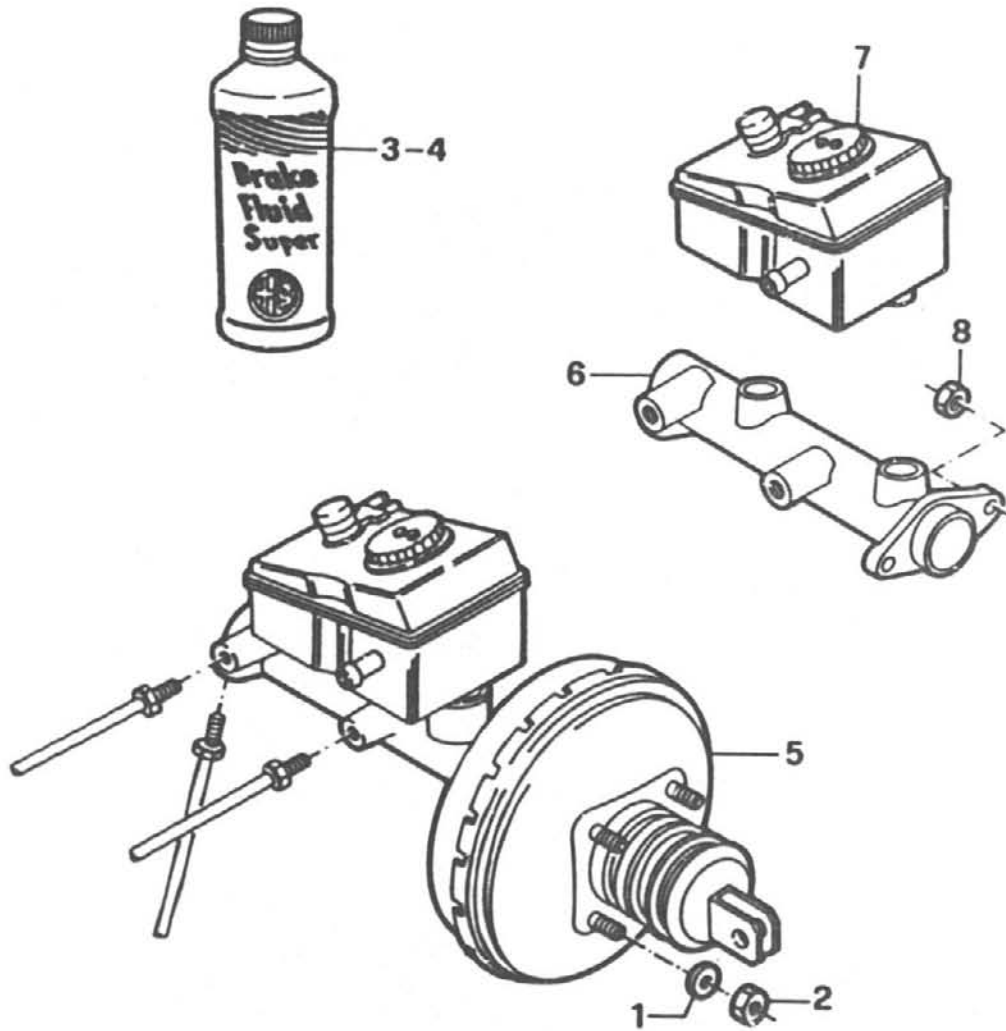

| pos. | TEILNUMMER | ref. | mg. benennung |
|------|-------------------|------|------------------------|
| 1 | 02100 61434 00 00 | | 4 SCHEIBE |
| 2 | 00161 00811 | | 4 MUTTER |
| 3 | 00607 10303 | | BREMSGEL LT.1 |
| 4 | 00607 10304 | | BREMSOEL LT.0,5 |
| 5 | 00605 01696 | | 1 BREMSKRAFTVERSTAERKE |
| 6 | 00607 65000 | | 1 HAUPTBREMSZYLINDER |
| 7 | 00607 65001 | | 1 BEHAELTER |
| 8 | 00607 65002 | | 2 MUTTER |

Q7

SPRINT
Ed. 87
Meccanica

1-1989

BENDITALIA

TAV. 21.12

c.c. 32

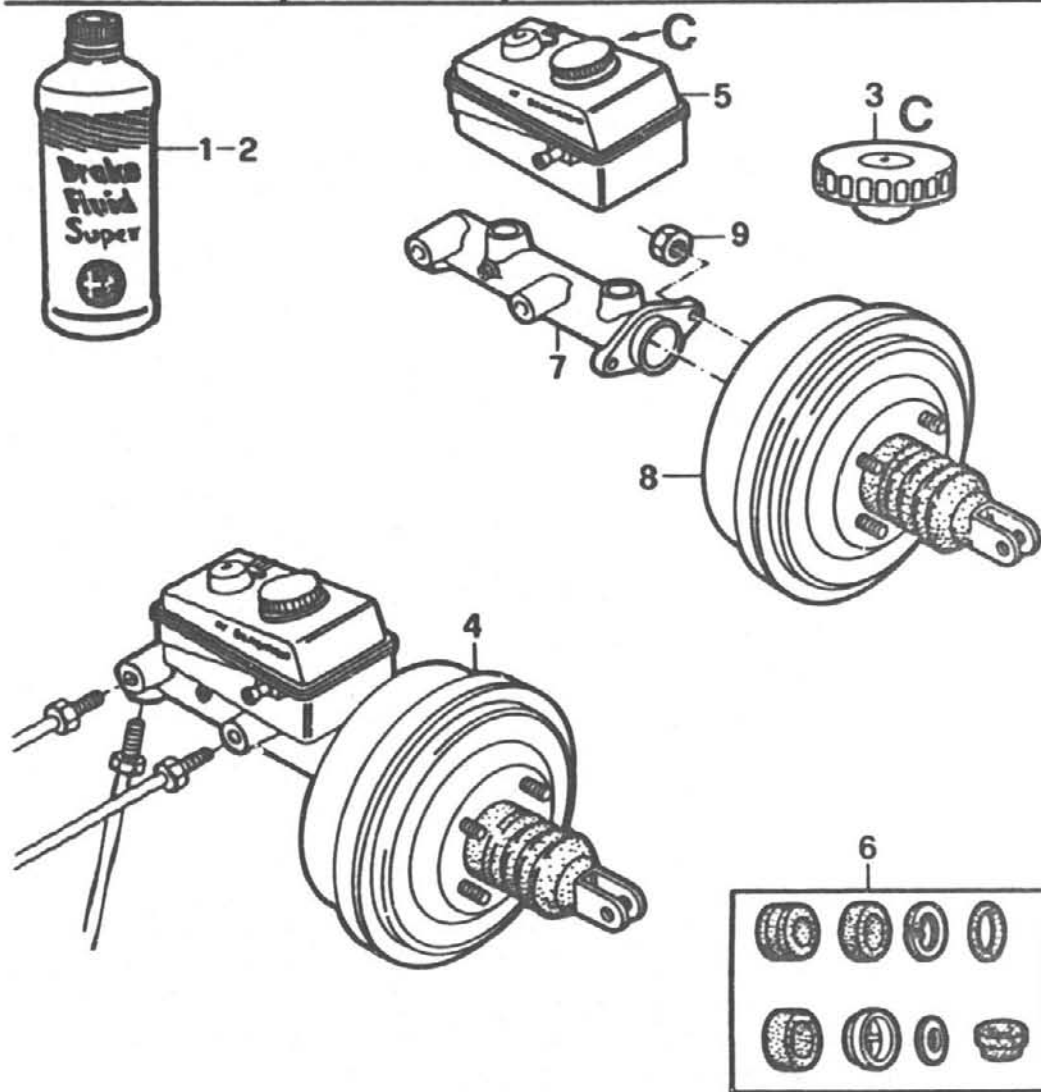

| pos. | TEILNUMMER | St. | mg. benennung |
|------|-------------|-----|----------------------|
| 1 | 00607 10303 | | BREMSOEL LT.1 |
| 2 | 00607 10304 | | BREMSOEL LT.0,5 |
| 3 | 00607 14536 | 1 | STOPFEN |
| 4 | 00605 01696 | 1 | BREMSKRAFTVERSTAERKE |
| 5 | 00607 49850 | i | BEHAELTER |
| 6 | 00607 49852 | 1 | REPARATURSATZ |
| 7 | 00607 50112 | 1 | HAUPTBREMSZYLINDER |
| 8 | 00607 50113 | 1 | BREMSKRAFTVERSTAERKE |
| 9 | 00607 65002 | 2 | MUTTER |

Q9

SPRINT
Ed. 87
Meccanica

1-1989

c.c. 1.7 - A

TAV. 21.50/1

c.c. 32

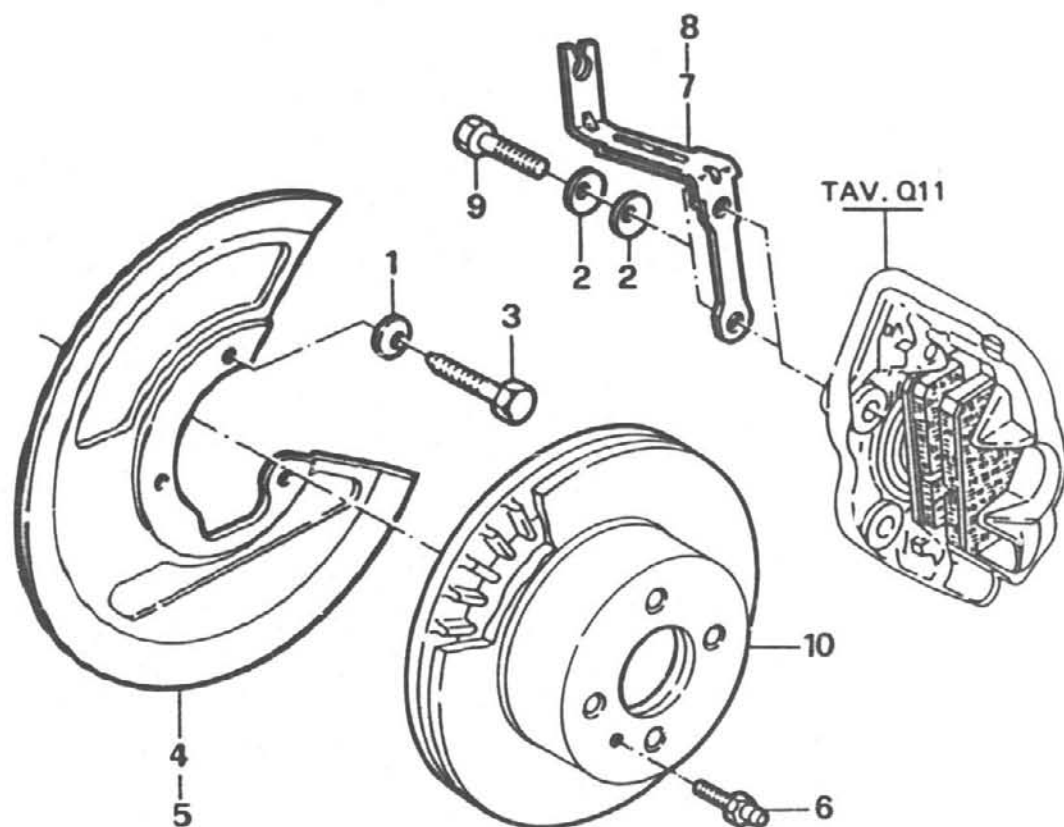

| pos. | TEILNUMMER | ref. | mg. benennung |
|------|-------------------|------|----------------|
| 1 | 02100 81408 00 00 | | 6 SCHEIBE |
| 2 | 02100 81440 00 00 | | 4 SCHEIBE |
| 3 | 00161 32211 | | 6 SCHRAUBE |
| 4 | 00605 01472 | ↗ | 1 STAUBSCHUTZ |
| 5 | 00605 01473 | ↘ | 1 STAUBSCHUTZ |
| 6 | 00605 01596 | | 4 SCHRAUBE |
| 7 | 00605 24132 | ↗ | 1 HALTER |
| 8 | 00605 24133 | ↘ | 1 HALTER |
| 9 | 00605 01452 | | 4 SCHRAUBE |
| 10 | 00605 14881 | | 2 BREMSSCHEIBE |

↗ Rechts
↘ Links

Q11

SPRINT
Ed. 87
Meccanica
1-1989

c.c. 1.7 - ATE - A

TAV. 21.52/1

c.c. 32

TAV. Q9

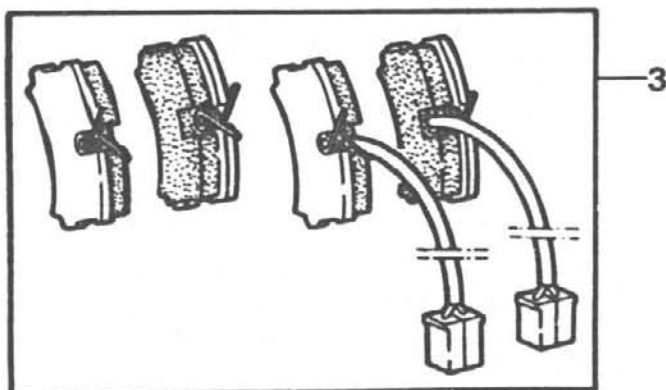
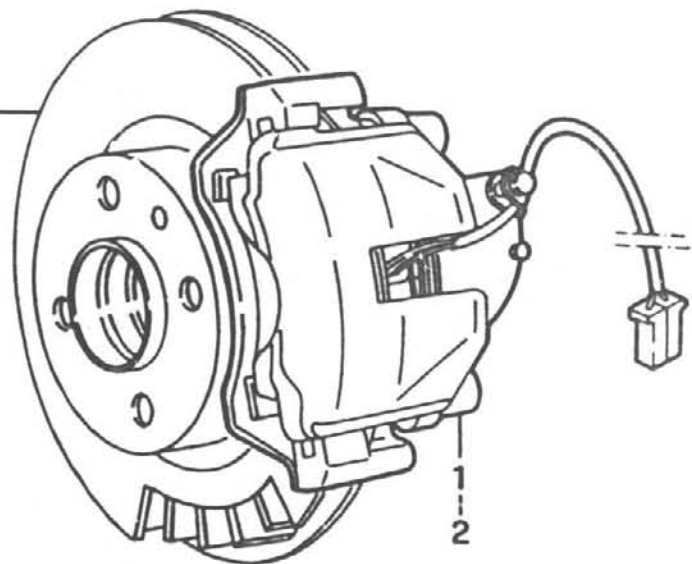

| pos. | TEILNUMMER | ref. | mg. | benennung |
|------|-------------|------|-----|---------------|
| 1 | 00605 14986 | ↗ | 1 | FESTSATTEL |
| 2 | 00605 14987 | ↖ | 1 | FESTSATTEL |
| 3 | 00607 50838 | | 1 | REPARATURSATZ |

↗ Rechts
↖ Links

Q12

SPRINT
Ed. 87
Meccanica
1-1989

c.c. 1.3 - BENDIX - A

TAV. 21.51

c.c. 32

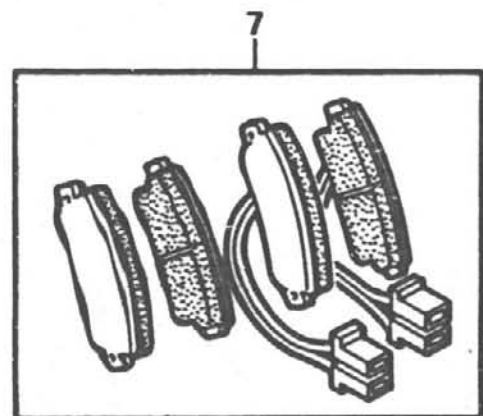
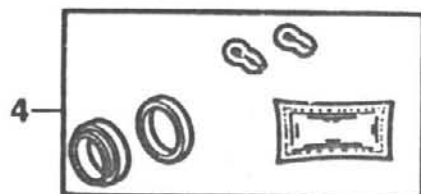
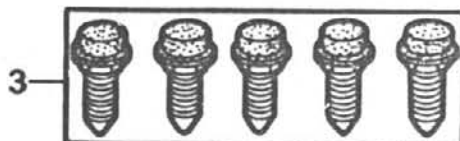
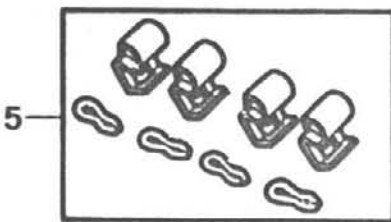
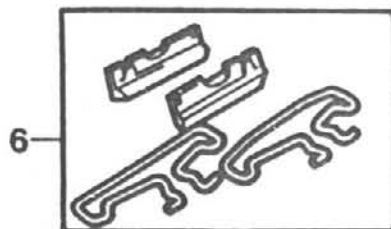
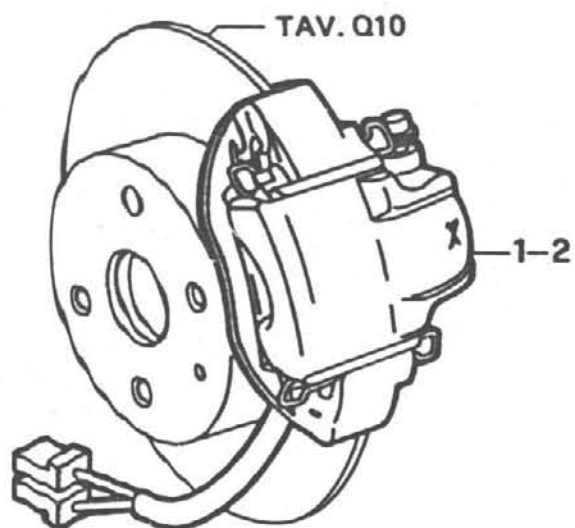

| pos. | TEILNUMMER | ref. | mg. | benennung |
|------|-------------|------|-----|---------------|
| 1 | 00605 01457 | ↗ | 1 | FESTSATTEL |
| 2 | 00605 01458 | ↖ | 1 | FESTSATTEL |
| 3 | 00607 49868 | | 1 | REPARATURSATZ |
| 4 | 00607 49881 | | 1 | REPARATURSATZ |
| 5 | 00607 49882 | | 1 | FEDERSATZ |
| 6 | 00607 49884 | | 1 | FEDERSATZ |
| 7 | 00607 50795 | | 1 | REPARATURSATZ |

↗ Rechts
↖ Links

Q13

SPRINT
Ed. 87
Meccanica
1-1989

c.c. 1.3 - ATE - A

TAV. 21.52

c.c. 32

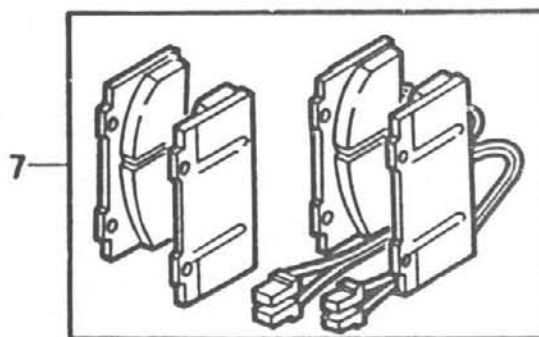
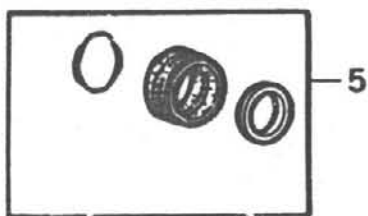
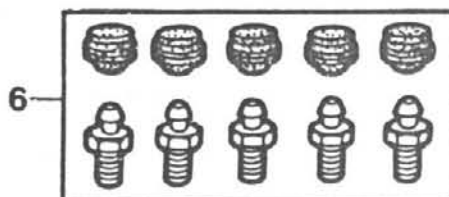
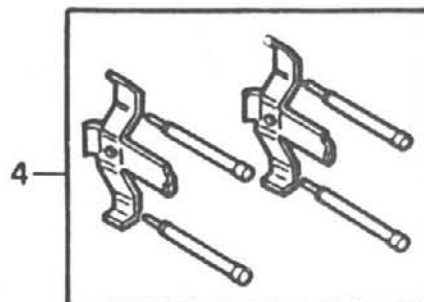
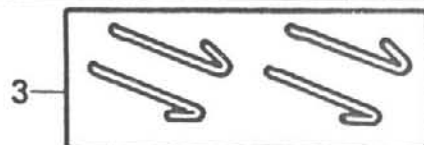
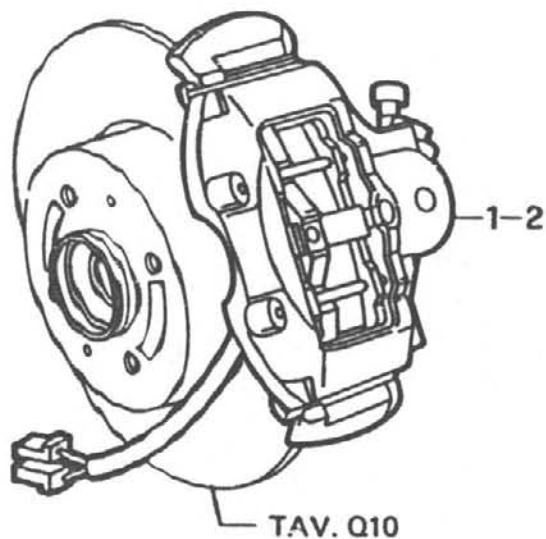

| pos. | TEIL NUMMER | ref. | mg. benennung |
|------|-------------|------|------------------|
| 1 | 00605 01455 | ◆ | 1 FESTSATEL |
| 2 | 00605 01456 | ◆ | 1 FESTSATEL |
| 3 | 00607 50773 | | 1 FEDERNSATZ |
| 4 | 00607 50774 | | 1 FEDERNSATZ |
| 5 | 00607 50775 | | 1 REPARATURSATZ |
| 6 | 00607 50776 | | 1 REPARATURSATZ |
| 7 | 00607 50796 | | 1 BREMSBELAGSATZ |

◆ Rechts
◆ Links

Q14

SPRINT
Ed. 87
Meccanica

1-1989

I.E. - ATE - A

TAV. 21.52/3

c.c. 32

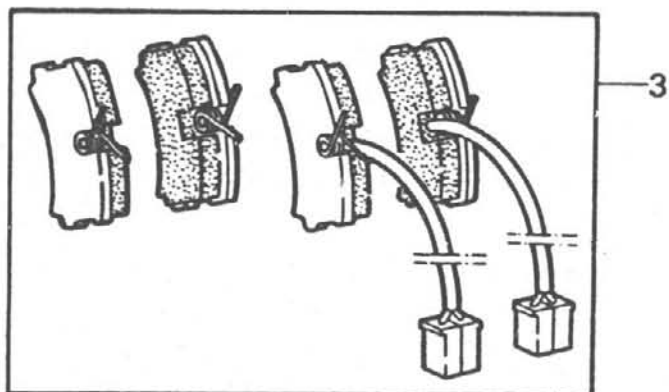
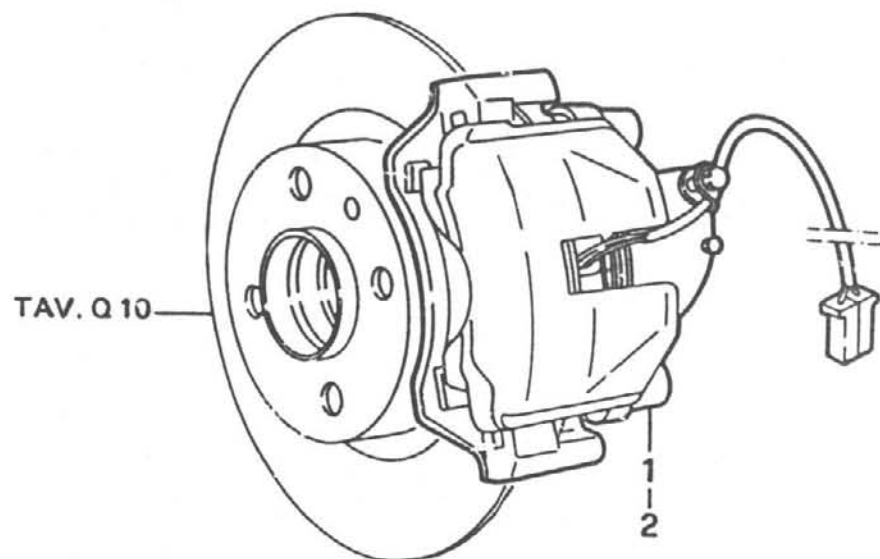

| pos. | TEILNUMMER | ref. | mg. benennung |
|------|-------------|------|-----------------|
| 1 | 00605 15390 | ◆ | 1 FESTSATTEL |
| 2 | 00605 15393 | ◆ | 1 FESTSATTEL |
| 3 | 00607 50465 | | 1 REPARATURSATZ |

◆ Rechts
◆ Links

Q15

SPRINT
Ed. 87
Meccanica

1-1989

P

TAV. 21.60

c.c. 32

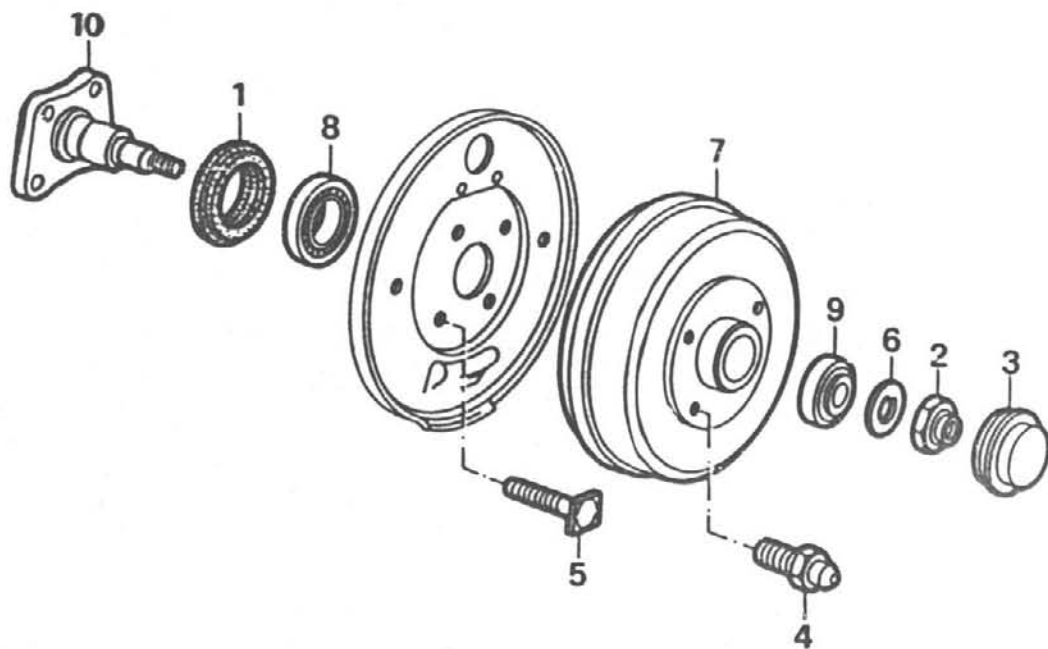

| pos. | TEILNUMMER | ref. | mg. benennung |
|------|-------------------|------|---------------|
| 1 | 00605 01947 | | 2 RING |
| 2 | 00605 01948 | | 2 MUTTER |
| 3 | 11900 21425 01 00 | | 2 DECKEL |
| 4 | 00605 01596 | | 1 SCHRAUBE |
| 5 | 00605 01580 | | 8 SCHRAUBE |
| 6 | 00605 01548 | | 2 SCHEIBE |
| 7 | 00605 01549 | | 2 TROMMEL |
| 8 | 00605 35940 | | 2 LAGER |
| 9 | 00605 35941 | | 2 LAGER |
| 10 | 00605 01559 | | 2 LAGERUNG |

Q16

SPRINT
Ed. 87
Meccanica

1-1989

BENDIX - P

TAV. 21.61

c.c. 32

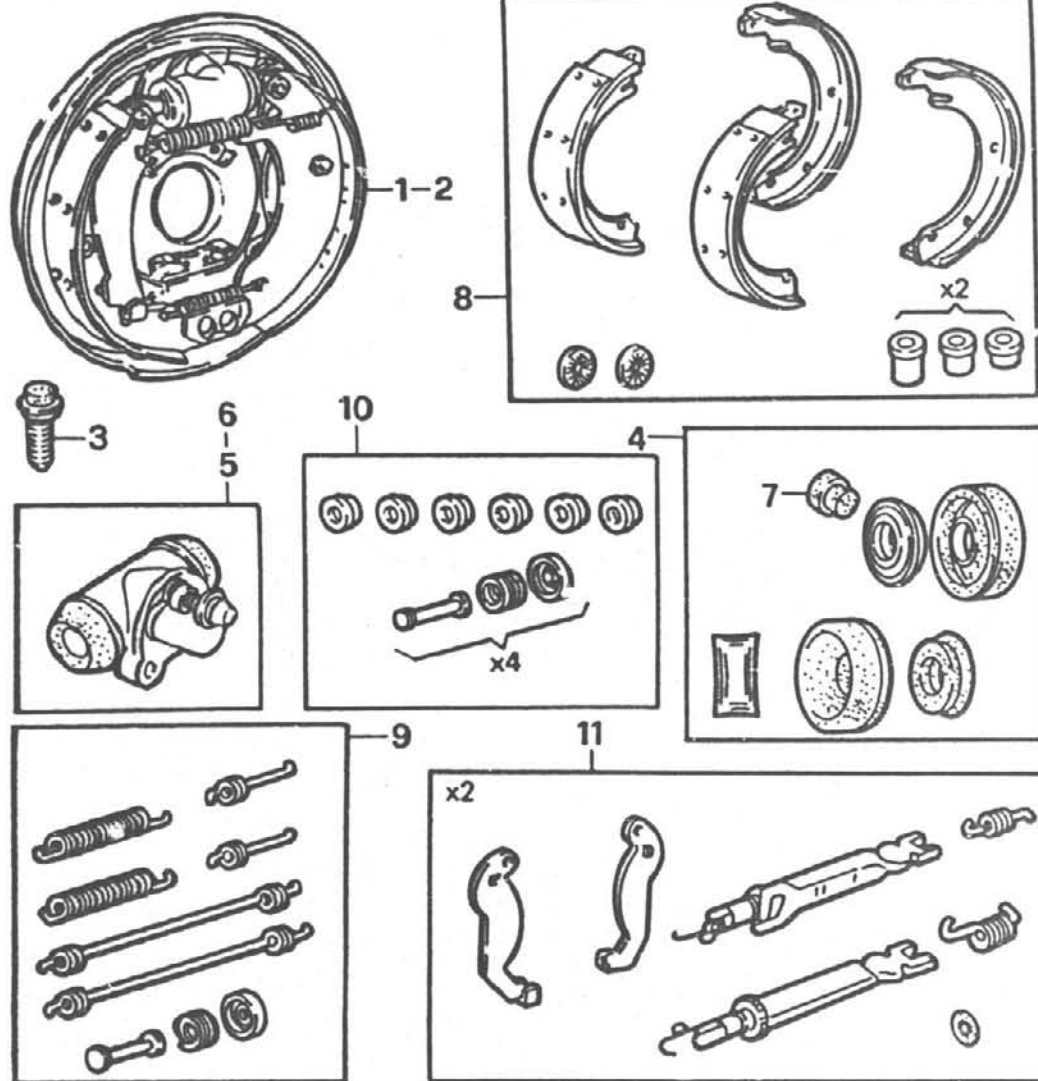

| pos. | TEILNUMMER | ref. | mg. benennung |
|------|-------------|------|------------------|
| 1 | 00605 01583 | ↗ | 1 ANKERPLATTE |
| 2 | 00605 01584 | ↖ | 1 ANKERPLATTE |
| 3 | 00607 49868 | | 2 ABLASSSCHRAUBE |
| 4 | 00607 49890 | | 1 REPARATURSATZ |
| 5 | 00607 50204 | ↗ | 1 ZYLINDER |
| 6 | 00607 50205 | ↖ | 1 ZYLINDER |
| 7 | 00607 50206 | | 1 STOPFEN |
| 8 | 00607 50207 | | 1 BACKE |
| 9 | 00607 50208 | | 1 FEDER |
| 10 | 00607 50209 | | 1 REPARATURSATZ |
| 11 | 00607 50210 | | 1 HEBEL |

↗ Rechts
↖ Links

Q17

SPRINT
Ed. 87
Meccanica
1-1989

I.E. - BENDIX - P

TAV. 21.61/5

c.c. 32

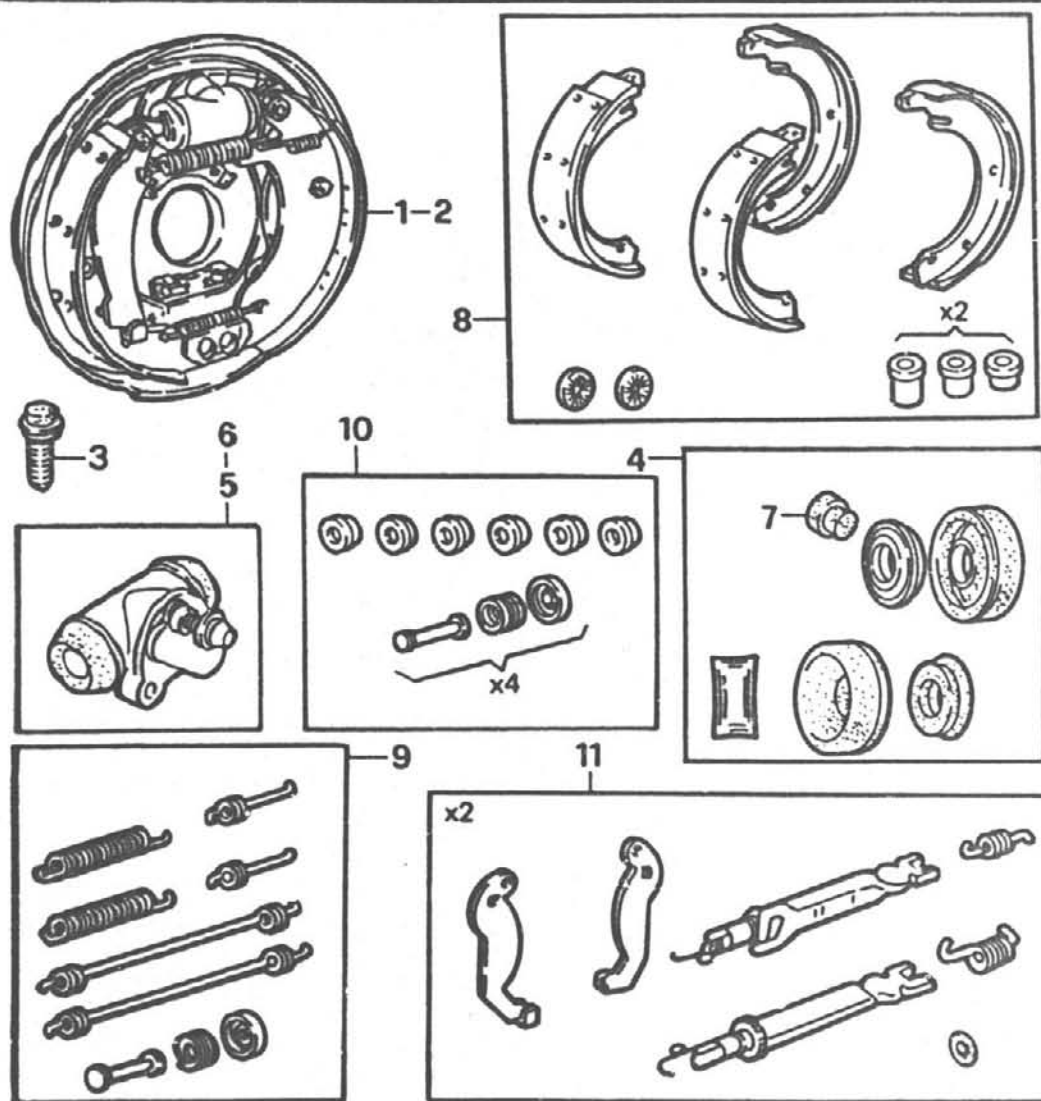

| pos. | TEILNUMMER | ref. | mg. | benennung |
|------|-------------|------|-----|------------------|
| 1 | 00605 14890 | ◆ | 1 | ANKERPLATTE |
| 2 | 00605 14885 | ◆ | 1 | ANKERPLATTE |
| 3 | 00607 49868 | | 2 | ABLASSSCHRAUBE |
| 4 | 00607 49890 | | 1 | REPARATURSATZ |
| 5 | 00607 50204 | ◆ | 1 | ZYLINDER |
| 6 | 00607 50205 | ◆ | 1 | ZYLINDER |
| 7 | 00607 50206 | | 1 | STOPFEN |
| 8 | 00607 50472 | | 1 | BACKE |
| 9 | 00607 50208 | | 1 | FEDER |
| 10 | 00607 50209 | | 1 | REPARATURSATZ |
| 11 | 00607 50210 | | 1 | HEBEL |
| 12 | 00607 50466 | | 1 | SATZ BREMSBACKEN |

◆ Links
◆ Rechts

R

1

TAV 21.85

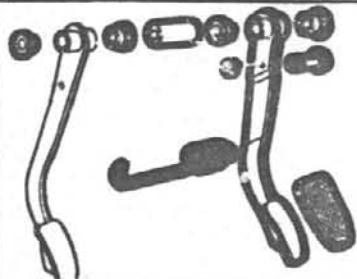

2

TAV

3

TAV 21.71



4

TAV 21.72

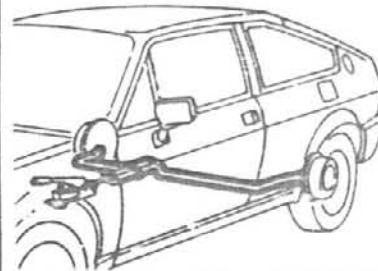

5

TAV

6

TAV

7

TAV

8

TAV

9

TAV

10

TAV

11

TAV

12

TAV

13

TAV

14

TAV

15

TAV

16

TAV

17

TAV

18

TAV

19

TAV

R₁

SPRINT
Ed. 87
Meccanica

1-1989

TAV. 21.85

c.c. 32

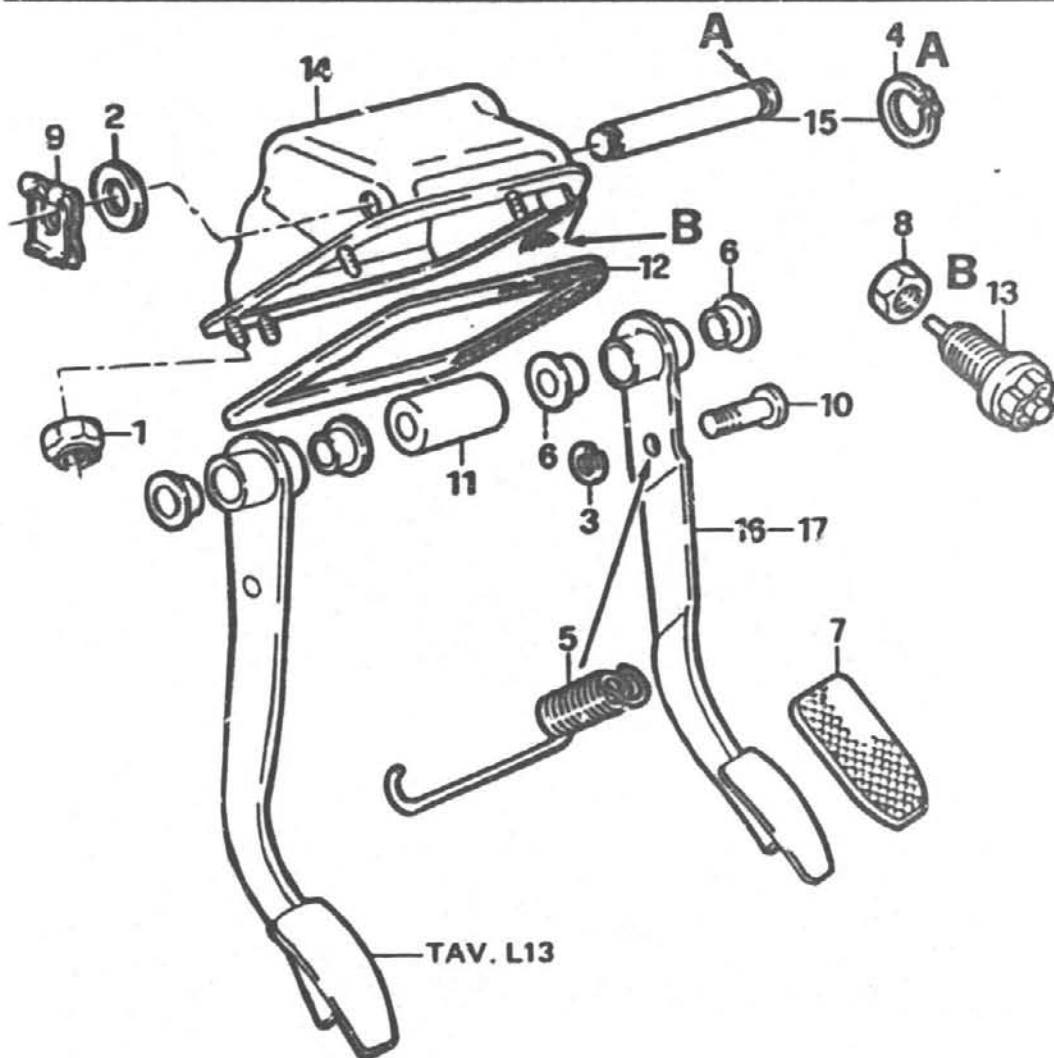

| pos. | TEILNUMMER | ref. | mg. benennung |
|------|-------------|------|-----------------|
| 1 | 00140 84411 | | 6 MUTTER |
| 2 | 00135 07611 | | 1 SCHEIBE |
| 3 | 00110 65970 | | 1 ANSCHLAG |
| 4 | 00110 66270 | | 1 ANSCHLAG |
| 5 | 00805 01328 | | 1 FEDER |
| 6 | 00805 01329 | | 2 BUECHSE |
| 7 | 00805 01331 | | 1 PEDALGUMMI |
| 8 | 00605 01191 | | 1 MUTTER |
| 9 | 00605 01332 | | 1 KLAMMER |
| 10 | 00605 01333 | | 1 BOLZEN |
| 11 | 00605 01675 | | 1 ABSTANDSTUECK |
| 12 | 00605 01680 | | 1 DICHTUNG |
| 13 | 00605 15008 | | 1 SCHALTER |
| 14 | 00605 01683 | | 1 LAGERUNG |
| 15 | 00605 01684 | | 1 BOLZEN |
| 16 | 00605 36870 | ● | 1 BREMSPEDAL |
| 17 | 00605 06664 | ■ | 1 BREMSPEDAL |

● G.S.
■ G.D.

R3

SPRINT
Ed. 87
Meccanica

1-1980

TAV. 21.71

c.c. 32

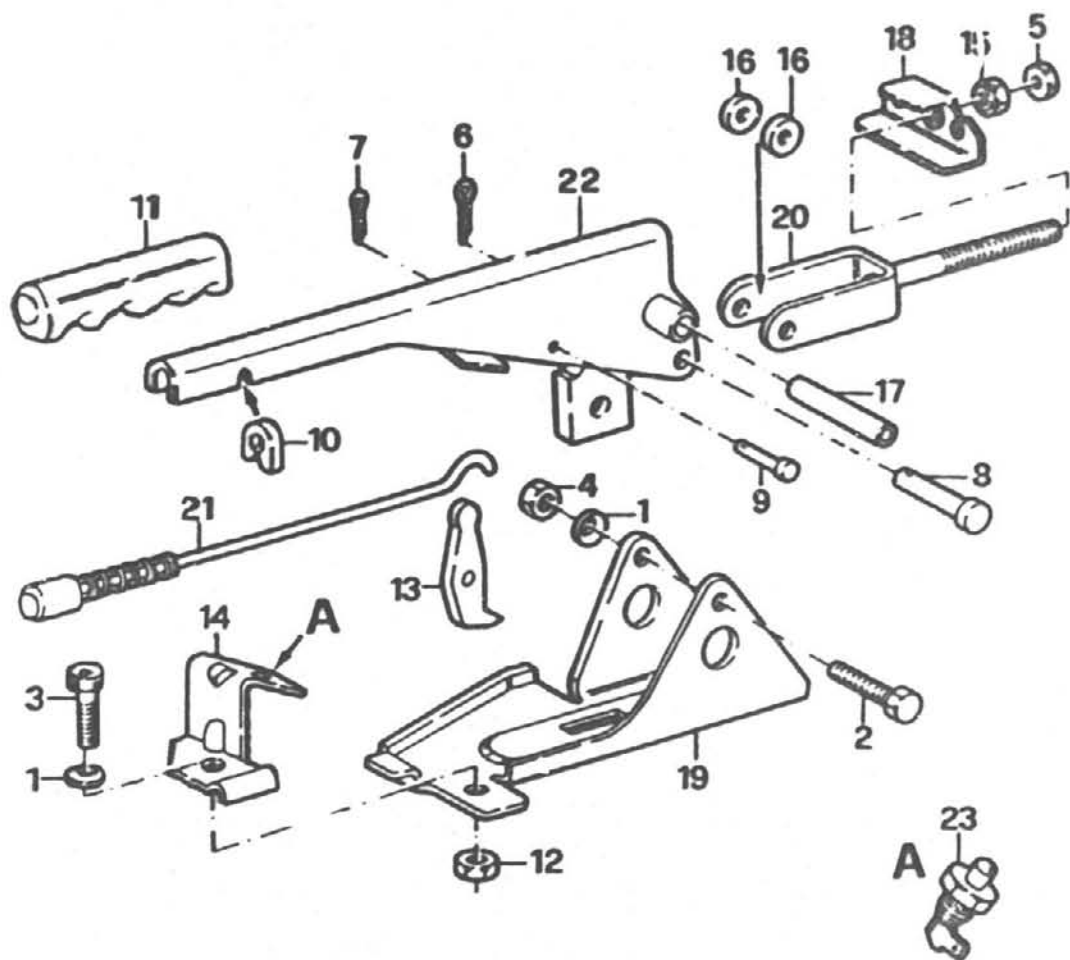

| pos. | TEILNUMMER | ref. | mg. benennung |
|------|-------------------|------|-----------------|
| 1 | 02100 81434 00 00 | | 3 SCHEIBE |
| 2 | 00160 44321 | | 1 SCHRAUBE |
| 3 | 00143 06421 | | 3 SCHRAUBE |
| 4 | 00161 00811 | | 1 MUTTER |
| 5 | 00161 02321 | | 1 MUTTER |
| 6 | 00107 66300 | | 1 SPLINT |
| 7 | 00107 66101 | | 1 SPLINT |
| 8 | 00100 41113 | | 1 VERBINDUNG |
| 9 | 00100 33213 | | 1 VERBINDUNG |
| 10 | 00605 01342 | | 1 STUETZE |
| 11 | 00605 01343 | | 1 GRIFF |
| 12 | 00605 18468 | | 3 ABSTANDSTUECK |
| 13 | 00605 01656 | | 1 HEBEL |
| 14 | 00605 01649 | | 1 WINKELSTUECK |
| 15 | 00605 01650 | | 1 MUTTER |
| 16 | 00605 01653 | | 2 ABSTANDSTUECK |
| 17 | 00605 01655 | | 1 ABSTANDSTUECK |
| 18 | 00605 01657 | | 1 KIPPEBEL |
| 19 | 00605 24067 | | 1 PLATTE |
| 20 | 00605 01660 | | 1 STANGE |
| 21 | 00605 01661 | | 1 STANGE |
| 22 | 00605 01663 | | 1 HEBEL |
| 23 | 00605 01664 | | 1 SCHALTER |

R4

SPRINT
Ed. 87
Meccanica
1-1980

TAV. 21.72

c.c. 32

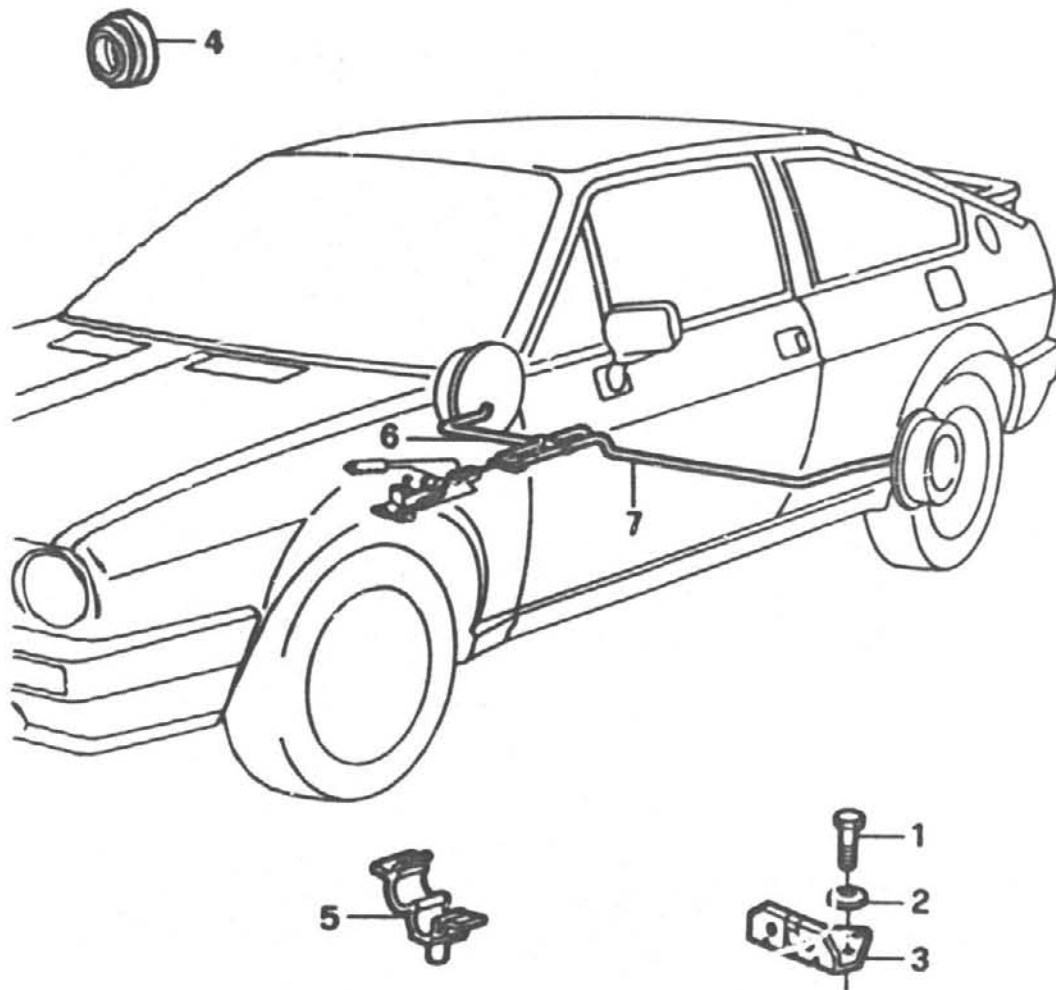

| pos. | TEILNUMMER | ref. | mg. benennung |
|------|-------------------|------|----------------|
| 1 | 00160 43213 | | 3 SCHRAUBE |
| 2 | 02100 81435 00 00 | | 3 SCHEIBE |
| 3 | 00605 01666 | | 1 WINKELSTUECK |
| 4 | 00605 01667 | | 2 GUMMITTEL |
| 5 | 00605 01668 | | 1 PUFFER |
| 6 | 00605 01672 | ◆ | 1 KABEL |
| 7 | 0060E 01673 | ◆ | 1 KABEL |

◆ Rechts
◆ Links

| | | | | |
|-----------|---|---|-----------|-----------|
| | 1 | 2 | 3 | 4 |
| S | INTERPRETAZIONE INDICE NUMERICO INTERPRETATION REPERTOIRE NUMERIQUE NUMERICAL INDEX INTERPRETATION DIE ERKLÄRUNG NUMMERISCHES SACHVERZEICHNIS INTERPRETACION INDICE NUMERICO | INDICE NUMERICO REPERTOIRE NUMERIQUE NUMERICAL INDEX NUMMERISCHES SACHVERZEICHNIS INDICE NUMERICO | | |
| 5 | 6 | 7 | 8 | 9 |
| | | | | |
| 10 | 11 | 12 | 13 | 14 |
| | | | | |
| 15 | 16 | 17 | | |
| | | | | |

S₁

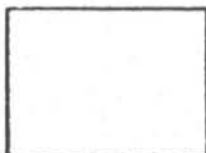

| CATEGORICO | Q. | COD. TAV. | C. M. | NUM. MOD. | SOSTITUENTE |
|----------------|----|-----------|-------|-----------|----------------|
| 11600563420200 | 10 | 61510 | | | |
| 11600585530100 | 08 | 68000 | D | 1252 | 02105045540000 |

Colonna categorici - Ersatzteil Nm. -

Colonna quantità - Stückzahlen

Colonna codice tavola - Bildtafel nr.

▲ Colonna codice modifica - Code Buchstaben

■ Colonna numero modifica - Rundschreiben Nr.

Colonna sostituyente - Neue Ersatzteil-Nr.

▲ Codice di modifica la cui interpretazione è sottospesificata.

- A - Particolare non più fornibile o annullato ad esaurimento
- B - Particolare annullato ad esaurimento e sostituito dal sottoriportato V.
- C - Particolare annullato e sostituito dal sottoriportato V.
- V - Particolare nuovo aggiunto in sostituzione del soprariportato B o C.
- N - Particolare nuovo aggiunto
- F - Particolare valido FINO al veicolo o motore n°...
- D - Particolare valido DAL veicolo o motore n°...

▲ Aufschlüsselung der Code-Buchstaben:

- A - Das betreffende Teil ist nicht mehr lieferbar bzw. wird nach Erschöpfung der Lagerbestände nicht mehr geliefert
- B - Das betreffende Teil wird nach Erschöpfung der Lagerbestände nicht mehr geliefert und durch ein neues Teil ersetzt (siehe Buchstabe "V")
- C - Das betreffende Teil wird nicht mehr geliefert und durch ein neues Teil ersetzt (siehe Buchstabe "V")
- V - Das betreffende Teil ersetzt eines der durch B oder C gekennzeichneten nicht mehr gelieferten Teile
- N - Vollkommen neues Teil
- F - Das betreffende Teil wird nur noch bis Fahrgestelle-bzw. Motor-Nr... geliefert
- D - Das betreffende Teil wird erst ab Fahrgestell-bzw. Motor - Nr... geliefert

- Numero del documento relativo all'introduzione della validità
- Nummer des Rundschreibens mit dem das Entfallen, die Neueinführung u.sw. des betreffenden Ersatzteils angekündigt worden ist.

- Per altre note vedi Tavola A9
- Weiterhinweise finden Sie in den Tafeln A10

Proprietà riservata. Riproduzione, anche parziale, vietata senza autorizzazione scritta della
ALFA-LANCIA INDUSTRIALE

Alle Rechte vorbehalten. Nachdruck, auch auszugsweise, nur mit schriftlicher Genehmigung
der **ALFA-LANCIA INDUSTRIALE**

R
W
X
Z

SOLO PER USO INTERNO ALFA ROMEO
NUR FÜR INTERNEN GEBRAUCH

INDICE NUMERICO GENERALE
 INDEX NUMERIQUE GENERAL
 MAIN NUMERICAL INDEX
 GENERELLES NUMERISCHES VERZEICHNIS
 INDICE NUMERICO GENERAL

INDICE NUMERICO AL BOLLETT. N 91033 DEL CATALOGO S 32

| CATEGORICO | Q. | COD. TAV. | C. SOSTITUENTE M. | CATEGORICO | Q. | COD. TAV. | C. SOSTITUENTE M. | CATEGORICO | Q. | COD. TAV. | C. SOSTITUENTE M. |
|------------|----|-----------|-------------------|------------|----|-----------|-------------------|------------|----|-----------|-------------------|
| 0009920623 | 1 | 42010 | | 0010444621 | 6 | 02030 | | 0010902211 | 2 | 01401 | |
| 0009921377 | 2 | 02400 | | 0010444621 | 6 | 02035 | | 0010902211 | 2 | 01405 | |
| 0009933301 | 1 | 42080 | | 0010458287 | 1 | 02600 | | 0010902211 | 5 | 02735 | |
| 0009934657 | 3 | 41210 | | 0010459787 | 1 | 02640 | | 0010902221 | 5 | 01090 | |
| 0009935949 | 1 | 42010 | | 0010615279 | 1 | 02115 | | 0010902221 | 5 | 01091 | |
| 0009936005 | 1 | 41210 | | 0010615379 | 1 | 02115 | | 0010902221 | 1 | 41000 | |
| 0009936598 | 1 | 42010 | | 0010726711 | 1 | 01310 | | 0010902221 | 1 | 41004 | |
| 0009936609 | 1 | 41210 | | 0010726711 | 1 | 01311 | | 0010902321 | 19 | 12020 | |
| 0009936616 | 1 | 42010 | | 0010726711 | 1 | 01315 | | 0010902411 | 1 | 01400 | |
| 0009938217 | 1 | 43010 | | 0010732011 | 1 | 42010 | | 0010902411 | 1 | 01401 | |
| 0009938217 | 1 | 43030 | | 0010732211 | 1 | 02701 | | 0010902411 | 1 | 01405 | |
| 0009938953 | 1 | 41210 | | 0010732211 | 1 | 02702 | | 0010902411 | 2 | 41001 | |
| 0009938956 | 1 | 41210 | | 0010732211 | 1 | 02845 | | 0010902421 | 1 | 02031 | |
| 0009939571 | 1 | 43011 | | 0010732211 | 2 | 04000 | | 0010902421 | 1 | 02036 | |
| 0009939572 | 1 | 43010 | | 0010732211 | 2 | 04001 | | 0010902611 | 3 | 01400 | |
| 0009939572 | 1 | 43011 | | 0010732411 | 1 | 31011 | | 0010902621 | 2 | 12220 | |
| 0009940727 | 1 | 43030 | | 0010732411 | 2 | 31120 | | 0010902623 | 8 | 01090 | |
| 0009941111 | 1 | 43010 | | 0010732517 | 1 | 31120 | | 0010902721 | 1 | 01080 | |
| 0010033213 | 1 | 21710 | | 0010766101 | 1 | 21710 | | 0010902721 | 1 | 01081 | |
| 0010041113 | 1 | 21710 | | 0010766300 | 1 | 21710 | | 0010902721 | 1 | 12220 | |
| 0010041513 | 2 | 02030 | | 0010766800 | 2 | 02030 | | 0010903211 | 2 | 01400 | |
| 0010041513 | 2 | 02035 | | 0010766800 | 2 | 02035 | | 0010903211 | 2 | 01401 | |
| 0010129084 | 1 | 02800 | | 0010791013 | 1 | 02600 | | 0010903211 | 2 | 01405 | |
| 0010129084 | 1 | 02805 | | 0010791013 | 1 | 02601 | | 0010903721 | 1 | 12221 | |
| 0010181711 | 1 | 02116 | | 0010791013 | 1 | 02605 | | 0010903723 | 2 | 03100 | |
| 0010184411 | 1 | 21000 | | 0010791411 | 1 | 02061 | | 0010935721 | 2 | 01400 | |
| 0010206020 | 1 | 01310 | | 0010841320 | 1 | 01310 | | 0010935721 | 2 | 01401 | |
| 0010206020 | 1 | 01311 | | 0010841320 | 1 | 01311 | | 0010935721 | 2 | 01405 | |
| 0010206020 | 1 | 01315 | | 0010841320 | 1 | 01315 | | 0010978011 | 1 | 02115 | |
| 0010261060 | 2 | 02116 | | 0010841520 | 2 | 01400 | | 0010978111 | 1 | 02702 | |
| 0010261160 | 2 | 02116 | | 0010942020 | 8 | 01010 | | 0010978423 | 1 | 32100 | |
| 0010261160 | 1 | 02805 | | 0010942020 | 4 | 01080 | | 0010979411 | 2 | 02060 | |
| 0010261850 | 1 | 04100 | | 0010942020 | 4 | 01081 | | 0010979411 | 2 | 02350 | |
| 0010261850 | 1 | 04105 | | 0010942020 | 3 | 01310 | | 0010979421 | 3 | 04000 | |
| 0010263450 | 1 | 01200 | | 0010942020 | 3 | 01311 | | 0010979421 | 3 | 04001 | |
| 0010263450 | 1 | 12020 | | 0010942020 | 3 | 01315 | | 0011030921 | 2 | 02701 | |
| 0010264650 | 2 | 02701 | | 0010942420 | 2 | 01060 | | 0011030921 | 2 | 02702 | |
| 0010264650 | 2 | 02702 | | 0010942420 | 2 | 01065 | | 0011054890 | | 02355 | |
| 0010264650 | 1 | 02800 | | 0010942420 | 2 | 12020 | | 0011055090 | | 02355 | |
| 0010275040 | 1 | 12020 | | 0010982111 | 1 | 41000 | | 0011059970 | 1 | 32060 | |
| 0010280050 | 2 | 02800 | | 0010982121 | 20 | 01200 | | 0011060870 | 2 | 14100 | |
| 0010280050 | 1 | 02805 | | 0010982121 | 4 | 01400 | | 0011061370 | 1 | 12120 | |
| 0010280050 | 1 | 12020 | | 0010982121 | 4 | 01401 | | 0011065770 | 1 | 02603 | |
| 0010289060 | 1 | 02350 | | 0010982121 | 4 | 01405 | | 0011065970 | 1 | 21850 | |
| 0010284450 | 2 | 01010 | | 0010982121 | 2 | 02737 | | 0011065970 | 1 | 21851 | |
| 0010298460 | 1 | 02805 | | 0010982121 | 3 | 12020 | | 0011066270 | 1 | 21850 | |
| 0010390511 | 1 | 02116 | | 0010982121 | 1 | 21090 | | 0011087870 | 2 | 12200 | |
| 0010444513 | 2 | 02350 | | 0010982123 | 1 | 02110 | | 0011182479 | 2 | 12020 | |
| 0010444613 | 5 | 43030 | | 0010902211 | 2 | 01400 | | 0011193779 | 1 | 32110 | |

INDICE NUMERICO AL BOLLETT. N 01033 DEL CATALOGO S 32

| CATEGORICO | Q. | COD. TAV. | C. SOSTITUENTE N. | CATEGORICO | Q. | COD. TAV. | C. SOSTITUENTE M. | CATEGORICO | Q. | COD. TAV. | C. SOSTITUENTE M. |
|------------|----|-----------|-------------------|------------|-------|-----------|-------------------|------------|----|-----------|-------------------|
| 0011194379 | 6 | 02702 | | 0012601370 | 3 | 03100 | | 0013577511 | 2 | 32100 | |
| 0011194379 | 3 | 04000 | | 0012601370 | 6 | 32110 | | 0013577911 | 8 | 02115 | |
| 0011194379 | 3 | 04001 | | 0012601379 | 9 | 01040 | | 0013577911 | 3 | 04100 | |
| 0011194379 | 2 | 41000 | | 0012601379 | 8 | 01090 | | 0013577911 | 3 | 04105 | |
| 0011194379 | 2 | 41004 | | 0012601379 | 2 | 02110 | | 0013577911 | 2 | 41001 | |
| 0011194379 | 14 | 01090 | | 0012601379 | 2 | 02114 | | 0013578311 | 2 | 41006 | |
| 0011194379 | 14 | 01091 | | 0012601379 | 4 | 04000 | | 0013579070 | 5 | 43030 | |
| 0011194379 | 1 | 02600 | | 0012601379 | 4 | 04001 | | 0013579471 | 1 | 02600 | |
| 0011194379 | 1 | 02601 | | 0012601379 | 9 | 12000 | | 0013579471 | 1 | 02601 | |
| 0011194379 | 1 | 02605 | | 0012601379 | 2 | 21020 | | 0013579760 | 6 | 01010 | |
| 0011194379 | 6 | 02701 | | 0012601479 | 1 | 21020 | | 0013579771 | 12 | 01096 | |
| 0011195470 | 1 | 32100 | | 0012601779 | 1 | 02061 | | 0013579771 | 12 | 01091 | |
| 0011198779 | 4 | 31010 | | 0012603879 | 1 | 02350 | | 0013579771 | 2 | 12220 | |
| 0011198779 | 4 | 31070 | | 0012605679 | 2 | 21000 | | 0013940870 | 1 | 12020 | |
| 0011306921 | 8 | 14100 | | 0012605679 | 2 | 21003 | | 0014039511 | 1 | 02116 | |
| 0011307021 | 4 | 01040 | | 0013100290 | 1 | 02037 | | 0014039511 | 1 | 02701 | |
| 0011343721 | 4 | 01010 | | 0013100390 | 2 | 02040 | | 0014048221 | 2 | 32110 | |
| 0011691311 | 4 | 31110 | | 0013100390 | 3 | 04110 | | 0014048811 | 1 | 31120 | |
| 0011691321 | 1 | 21000 | | 0013100390 | 3 | 04111 | | 0014050511 | 2 | 31110 | |
| 0011691321 | 1 | 21003 | | 0013100390 | 3 | 04115 | | 0014084011 | 3 | 02702 | |
| 0012056340 | 4 | 41000 | | 0013100390 | 1 | 21000 | | 0014084211 | 2 | 02115 | |
| 0012056440 | 6 | 41000 | | 0013100590 | 1 | 02031 | | 0014084211 | 2 | 02116 | |
| 0012056440 | 6 | 41006 | | 0013100590 | 1 | 02036 | | 0014084211 | 4 | 02330 | |
| 0012164711 | 2 | 01400 | | 0013100590 | 1 | 02045 | | 0014084411 | 6 | 21850 | |
| 0012164711 | 2 | 01401 | | 0013100790 | 1 | 02045 | | 0014115780 | 1 | 02735 | |
| 0012164711 | 2 | 01405 | | 0013100790 | 1 | 02330 | | 0014161570 | 1 | 32110 | |
| 0012164711 | 5 | 12020 | | 0013100790 | 1 | 02735 | | 0014193190 | 1 | 04100 | |
| 0012164711 | 1 | 21020 | | 0013100790 | 3 | 02737 | | 0014193190 | 1 | 04105 | |
| 0012164711 | 1 | 42010 | | 0013100990 | 3 | 02037 | | 0014201980 | 2 | 02355 | |
| 0012164721 | 2 | 12000 | | 0013100990 | 1 | 02737 | | 0014201980 | 1 | 04105 | |
| 0012164721 | 2 | 32250 | | 0013101190 | 1 | 02330 | | 0014305721 | 4 | 01091 | |
| 0012168190 | 2 | 02031 | | 0013101390 | 4 | 04110 | | 0014305721 | 4 | 02060 | |
| 0012168190 | 2 | 02036 | | 0013101390 | 2 | 04111 | | 0014306421 | 4 | 02603 | |
| 0012574511 | 4 | 31120 | | 0013101390 | 04115 | | | 0014306421 | 3 | 21710 | |
| 0012601079 | 1 | 02600 | | 0013101590 | 2 | 02800 | | 0014307521 | 8 | 14100 | |
| 0012601079 | 1 | 02735 | | 0013101590 | 2 | 02805 | | 0014308121 | 1 | 02800 | |
| 0012601079 | 3 | 04110 | | 0013101790 | 4 | 02800 | | 0014308121 | 1 | 02805 | |
| 0012601079 | 3 | 04111 | | 0013101790 | 4 | 02805 | | 0014328300 | 4 | 01310 | |
| 0012601079 | 3 | 04115 | | 0013101990 | 4 | 04110 | | 0014328300 | 4 | 01311 | |
| 0012601279 | 1 | 01080 | | 0013101990 | 4 | 04111 | | 0014328300 | 4 | 01315 | |
| 0012601279 | 1 | 01081 | | 0013101990 | 4 | 04115 | | 0014328401 | 3 | 01010 | |
| 0012601279 | 2 | 01400 | | 0013102190 | 1 | 02841 | | 0014329801 | 16 | 01010 | |
| 0012601279 | 8 | 01401 | | 0013102190 | 1 | 02845 | | 0014417821 | 1 | 02350 | |
| 0012601279 | 8 | 01405 | | 0013102890 | 1 | 02330 | | 0014452980 | 2 | 12221 | |
| 0012601279 | 2 | 03100 | | 0013102990 | 1 | 02705 | | 0014454380 | 1 | 43050 | |
| 0012601279 | 3 | 12070 | | 0013103090 | 1 | 02330 | | 0014600570 | 1 | 12200 | |
| 0012601279 | 4 | 12220 | | 0013268010 | 1 | 43050 | | 0014601070 | 3 | 12200 | |
| 0012601370 | 8 | 01060 | | 0013506611 | 2 | 02350 | | 0014601070 | 1 | 12220 | |
| 0012601370 | 8 | 01065 | | 0013507611 | 1 | 21850 | | 0014601070 | 1 | 12221 | |

INDICE NUMERICO AL BOLLETT. N 01033 DEL CATALOGO S 32

| CATEGORICO | Q. | COD. TAV. | C. SOSTITUENTE M. | CATEGORICO | Q. | COD. TAV. | C. SOSTITUENTE M. | CATEGORICO | Q. | COD. TAV. | C. SOSTITUENTE M. |
|------------|----|-----------|-------------------|------------|----|-----------|-------------------|----------------|----|-----------|-------------------|
| 0014642594 | 2 | 02037 | | 0016043221 | 2 | 02601 | | 0016133221 | 1 | 02601 | |
| 0014648290 | 1 | 02037 | | 0016043221 | 2 | 02603 | | 0016133221 | 1 | 02605 | |
| 0014648390 | 2 | 21000 | | 0016043221 | 4 | 12000 | | 0016136821 | 2 | 21020 | |
| 0014648390 | 2 | 41001 | | 0016043321 | 6 | 11500 | | 0016136921 | 2 | 01040 | |
| 0014648590 | 1 | 02735 | | 0016043411 | 4 | 02800 | | 0016137323 | 1 | 32110 | |
| 0014648790 | 1 | 02031 | | 0016043611 | 3 | 02330 | | 0016139821 | 1 | 21020 | |
| 0014648790 | 1 | 02036 | | 0016043621 | 8 | 01090 | | 0016142921 | 2 | 31120 | |
| 0015115621 | 4 | 04000 | | 0016043621 | 4 | 02603 | | 0016143921 | 2 | 31010 | |
| 0015115621 | 4 | 04001 | | 0016043921 | 1 | 12120 | | 0016143921 | 2 | 31070 | |
| 0015248423 | 1 | 12221 | | 0016043933 | 2 | 32110 | | 0028043180 | 1 | 43010 | |
| 0015540421 | 4 | 31070 | | 0016044121 | 4 | 02800 | | 00323520045214 | | 02031 | |
| 0015540523 | 1 | 12120 | | 0016044121 | 4 | 02805 | | 0060501092 | 1 | 41001 | |
| 0015540721 | 1 | 21500 | | 0016044121 | 4 | 12000 | | 0060501094 | 1 | 32050 | |
| 0015541221 | 2 | 31010 | | 0016044321 | 1 | 21710 | | 0060501191 | 1 | 21850 | |
| 0015541321 | 2 | 31010 | | 0016044321 | 4 | 32050 | | 0060501195 | 1 | 21850 | |
| 0015541921 | 1 | 31120 | | 0016044421 | 1 | 02800 | | 0060501222 | 1 | 42010 | |
| 0015644201 | 1 | 02735 | | 0016044421 | 2 | 31110 | | 0060501237 | 1 | 11200 | |
| 0015644507 | 4 | 32100 | | 0016044621 | 1 | 02701 | | 0060501237 | 1 | 11210 | |
| 0015888721 | 1 | 12020 | | 0016044621 | 3 | 02845 | | 0060501245 | 1 | 11100 | |
| 0015888721 | 4 | 31120 | | 0016100811 | 2 | 02061 | | 0060501248 | 1 | 12120 | |
| 0015896211 | | 41006 | | 0016100811 | 2 | 02110 | | 0060501250 | 1 | 12120 | |
| 0015896211 | 1 | 42010 | | 0016100811 | 6 | 02350 | | 0060501251 | 1 | 12120 | |
| 0015896211 | 1 | 01093 | | 0016100811 | 1 | 02701 | | 0060501259 | 1 | 12160 | |
| 0015896211 | 1 | 01091 | | 0016100811 | 1 | 02702 | | 0060501260 | 1 | 12161 | |
| 0015896211 | 4 | 02115 | | 0016100811 | 14 | 02800 | | 0060501261 | 1 | 12161 | |
| 0015896211 | 1 | 02600 | | 0016100811 | 8 | 02840 | | 0060501266 | 1 | 12160 | |
| 0015896211 | 1 | 02601 | | 0016100811 | 8 | 02841 | | 0060501269 | 1 | 12160 | |
| 0015896211 | 1 | 02605 | | 0016100811 | 7 | 02845 | | 0060501270 | 1 | 12120 | |
| 0015896211 | 5 | 02701 | | 0016100811 | 2 | 04000 | | 0060501271 | 2 | 12160 | |
| 0015896211 | 5 | 02702 | | 0016100811 | 2 | 04001 | | 0060501271 | 2 | 12161 | |
| 0015896211 | 4 | 02735 | | 0016100811 | 2 | 11200 | | 0060501272 | 2 | 12160 | |
| 0015896211 | 1 | 02840 | | 0016100811 | 2 | 21020 | | 0060501272 | 2 | 12161 | |
| 0015896211 | 1 | 02841 | | 0016100811 | 4 | 21100 | | 0060501274 | 1 | 12200 | |
| 0015896211 | 1 | 02845 | | 0016100811 | 1 | 21710 | | 0060501275 | 1 | 12200 | |
| 0015896211 | 3 | 04100 | | 0016109811 | 8 | 31011 | | 0060501276 | 1 | 12200 | |
| 0015896211 | 3 | 04105 | | 0016100811 | 2 | 31110 | | 0060501277 | 1 | 12200 | |
| 0015896211 | 1 | 41000 | | 0016100811 | 3 | 32100 | | 0060501278 | 1 | 14100 | |
| 0015896411 | 2 | 02115 | | 0016100811 | 1 | 32110 | | 0060501286 | 1 | 12000 | |
| 0015896411 | 1 | 02600 | | 0016100811 | 2 | 01040 | | 0060501287 | 1 | 12000 | |
| 0015896411 | 1 | 02601 | | 0016100821 | 14 | 02805 | | 0060501290 | 1 | 14300 | |
| 0015979111 | 2 | 01010 | | 0016102311 | 1 | 42050 | | 0060501291 | 2 | 14300 | |
| 0015971421 | 2 | 01010 | | 0016102311 | 1 | 42010 | | 0060501297 | 2 | 16400 | |
| 0015971421 | 2 | 12000 | | 0016102321 | 1 | 21710 | | 0060501312 | 2 | 12020 | |
| 0015971821 | 1 | 42010 | | 0016112111 | 1 | 32250 | | 0060501314 | 1 | 12000 | |
| 0015972621 | 1 | 12020 | | 0016112211 | 1 | 12221 | | 0060501317 | 2 | 01041 | |
| 0016043211 | 2 | 02705 | | 0016132211 | 6 | 21500 | | 0060501320 | 1 | 12000 | |
| 0016043213 | 3 | 21720 | | 0016132211 | 6 | 21501 | | 0060501321 | 1 | 01040 | |
| 0016043221 | 2 | 02114 | | 0016132311 | 1 | 02037 | | 0060501325 | 1 | 12000 | |
| 0016043221 | 2 | 02600 | | 0016133221 | 1 | 02600 | | 0060501326 | 1 | 01041 | |

INDICE NUMERICO AL BOLLETT. N 01033 DEL CATALOGO S 32

| CATEGORICO | Q. | COD. TAV. | C. SOSTITUENTE M. | CATEGORICO | Q. | COD. TAV. | C. SOSTITUENTE M. | CATEGORICO | Q. | COD. TAV. | C. SOSTITUENTE M. |
|------------|----|-----------|-------------------|------------|----|-----------|-------------------|------------|----|-----------|-------------------|
| 0060501328 | 1 | 21850 | | 0060501472 | 1 | 21501 | | 0060501663 | 1 | 21710 | |
| 0060501328 | 1 | 21851 | | 0060501473 | 1 | 21500 | | 0060501664 | 1 | 21710 | |
| 0060501329 | 2 | 21850 | | 0060501473 | 1 | 21501 | | 0060501666 | 1 | 21720 | |
| 0060501329 | 2 | 21851 | | 0060501474 | 2 | 32050 | | 0060501667 | 2 | 21720 | |
| 0060501331 | 1 | 21850 | | 0060501475 | 2 | 32050 | | 0060501668 | 1 | 21720 | |
| 0060501331 | 1 | 21851 | | 0060501478 | 1 | 32060 | | 0060501670 | 1 | 31120 | |
| 0060501332 | 1 | 21850 | | 0060501489 | 1 | 32110 | | 0060501672 | 1 | 21720 | |
| 0060501333 | 1 | 21850 | | 0060501531 | 1 | 32250 | | 0060501673 | 1 | 21720 | |
| 0060501333 | 1 | 21851 | | 0060501536 | 1 | 32250 | | 0060501675 | 1 | 21350 | |
| 0060501335 | 1 | 21005 | | 0060501548 | 2 | 21600 | | 0060501675 | 1 | 21851 | |
| 0060501336 | 1 | 21020 | | 0060501549 | 2 | 21600 | | 0060501680 | 1 | 21350 | |
| 0060501337 | 2 | 21000 | | 0060501559 | 2 | 21600 | | 0060501683 | 1 | 21350 | |
| 0060501337 | 2 | 21003 | | 0060501563 | 2 | 31110 | | 0060501684 | 1 | 21850 | |
| 0060501339 | 1 | 21000 | | 0060501567 | 2 | 31110 | | 0060501686 | 1 | 21851 | |
| 0060501339 | 1 | 21003 | | 0060501569 | 2 | 31110 | | 0060501696 | 1 | 21100 | |
| 0060501342 | 1 | 21710 | | 0060501571 | 1 | 31120 | | 0060501696 | 1 | 21120 | |
| 0060501343 | 1 | 21710 | | 0060501572 | 2 | 31120 | | 0060501702 | 2 | 21005 | |
| 0060501344 | 2 | 02031 | | 0060501580 | 8 | 21600 | | 0060501704 | 1 | 21000 | |
| 0060501344 | 2 | 02036 | | 0060501580 | 8 | 31120 | | 0060501704 | 1 | 21003 | |
| 0060501344 | 3 | 02037 | | 0060501583 | 1 | 21610 | | 0060501705 | 1 | 21000 | |
| 0060501373 | 2 | 31000 | | 0060501584 | 1 | 21610 | | 0060501705 | 1 | 21003 | |
| 0060501376 | 2 | 31000 | | 0060501596 | 4 | 21500 | | 0060501706 | 1 | 21000 | |
| 0060501377 | 2 | 31000 | | 0060501596 | 4 | 21501 | | 0060501711 | 2 | 21005 | |
| 0060501382 | 1 | 31000 | | 0060501596 | 1 | 21600 | | 0060501718 | 1 | 21005 | |
| 0060501383 | 1 | 31000 | | 0060501597 | 16 | 31200 | | 0060501719 | 1 | 21005 | |
| 0060501385 | 2 | 31000 | | 0060501598 | 16 | 31200 | | 0060501720 | 1 | 21005 | |
| 0060501387 | 2 | 31010 | | 0060501615 | 5 | 31200 | | 0060501721 | 1 | 21005 | |
| 0060501394 | 4 | 31010 | | 0060501622 | 1 | 12220 | | 0060501723 | 1 | 21005 | |
| 0060501401 | 1 | 31010 | | 0060501623 | 1 | 12220 | | 0060501727 | 2 | 21000 | |
| 0060501402 | 1 | 31010 | | 0060501625 | 1 | 12220 | | 0060501727 | 2 | 21003 | |
| 0060501403 | 1 | 31010 | | 0060501626 | 1 | 12220 | | 0060501730 | 1 | 21000 | |
| 0060501405 | 8 | 31010 | | 0060501627 | 1 | 12220 | | 0060501731 | 1 | 21000 | |
| 0060501407 | 2 | 31011 | | 0060501628 | 1 | 12221 | | 0060501731 | 1 | 21003 | |
| 0060501408 | 2 | 31011 | | 0060501629 | 1 | 12221 | | 0060501731 | 1 | 21003 | |
| 0060501426 | 1 | 31011 | | 0060501634 | 1 | 12220 | | 0060501732 | 1 | 21000 | |
| 0060501427 | 1 | 31011 | | 0060501634 | 1 | 12221 | | 0060501732 | 1 | 21003 | |
| 0060501432 | 2 | 31011 | | 0060501637 | 1 | 12220 | | 0060501732 | 1 | 21005 | |
| 0060501433 | 2 | 31011 | | 0060501639 | 1 | 12221 | | 0060501733 | 1 | 21020 | |
| 0060501443 | 1 | 31011 | | 0060501640 | 1 | 12221 | | 0060501737 | 1 | 21020 | |
| 0060501444 | 1 | 31011 | | 0060501642 | 1 | 12221 | | 0060501738 | 1 | 21020 | |
| 0060501445 | 2 | 31011 | | 0060501643 | 1 | 12221 | | 0060501744 | 2 | 31011 | |
| 0060501446 | 2 | 31010 | | 0060501649 | 1 | 21710 | | 0060501745 | 2 | 31011 | |
| 0060501452 | 4 | 21501 | | 0060501650 | 1 | 21710 | | 0060501746 | 1 | 31011 | |
| 0060501453 | 2 | 21500 | | 0060501653 | 2 | 21710 | | 0060501747 | 1 | 31011 | |
| 0060501455 | 1 | 21520 | | 0060501655 | 1 | 21710 | | 0060501748 | 2 | 31011 | |
| 0060501456 | 1 | 21520 | | 0060501656 | 1 | 21710 | | 0060501754 | 2 | 31011 | |
| 0060501457 | 1 | 21510 | | 0060501657 | 1 | 21710 | | 0060501755 | 2 | 31010 | |
| 0060501458 | 1 | 21510 | | 0060501660 | 1 | 21710 | | 0060501911 | 4 | 31110 | |
| 0060501472 | 1 | 21500 | | 0060501661 | 1 | 21710 | | 0060501913 | 4 | 31110 | |

INDICE NUMERICO AL BOLLETT. N 81033 DEL CATALOGO S 32

| CATEGORICO | Q. | COD. TAV. | C. SOSTITUENTE M. | CATEGORICO | Q. | COD. TAV. | C. SOSTITUENTE M. | CATEGORICO | Q. | COD. TAV. | C. SOSTITUENTE M. |
|------------|----|-----------|-------------------|------------|----|-----------|-------------------|------------|----|-----------|-------------------|
| 0060501915 | 2 | 31110 | | 0060502563 | 4 | 12160 | | 0060502654 | 1 | 12220 | |
| 0060501916 | 2 | 31110 | | 0060502563 | 4 | 12161 | | 0060502655 | 1 | 12220 | |
| 0060501917 | 2 | 31110 | | 0060502564 | 1 | 12161 | | 0060502657 | 1 | 11500 | |
| 0060501918 | 4 | 31110 | | 0060502596 | 1 | 12161 | | 0060502658 | 1 | 11500 | |
| 0060501919 | 2 | 31120 | | 0060502597 | 1 | 12120 | | 0060502660 | 1 | 11300 | |
| 0060501921 | 4 | 31110 | | 0060502598 | 2 | 12120 | | 0060502661 | 1 | 11500 | |
| 0060501922 | 2 | 31110 | | 0060502600 | 1 | 12120 | | 0060502665 | 1 | 11310 | |
| 0060501922 | 8 | 31120 | | 0060502601 | 2 | 12160 | | 0060502666 | 1 | 11300 | |
| 0060501925 | 2 | 31120 | | 0060502604 | 2 | 12120 | | 0060502666 | 1 | 11310 | |
| 0060501930 | 2 | 31110 | | 0060502605 | 1 | 12120 | | 0060502668 | 1 | 11500 | |
| 0060501934 | 2 | 31110 | | 0060502608 | 1 | 12120 | | 0060502669 | 1 | 14100 | |
| 0060501936 | 2 | 31110 | | 0060502610 | 1 | 12120 | | 0060502670 | 1 | 14100 | |
| 0060501937 | 2 | 31110 | | 0060502615 | 1 | 12120 | | 0060502672 | 2 | 14100 | |
| 0060501938 | 1 | 31110 | | 0060502616 | 1 | 12120 | | 0060502673 | 1 | 14100 | |
| 0060501942 | 2 | 31110 | | 0060502618 | 1 | 12161 | | 0060502674 | 2 | 14100 | |
| 0060501947 | 2 | 21600 | | 0060502619 | 1 | 12200 | | 0060502675 | | 14100 | |
| 0060501948 | 2 | 21600 | | 0060502620 | 1 | 12200 | | 0060502676 | | 14100 | |
| 0060501972 | 1 | 31110 | | 0060502621 | 1 | 12200 | | 0060502677 | | 14100 | |
| 0060502526 | 1 | 12020 | | 0060502622 | 1 | 12020 | | 0060502678 | | 14100 | |
| 0060502527 | 1 | 12020 | | 0060502625 | 2 | 12200 | | 0060502679 | | 14100 | |
| 0060502528 | 1 | 12020 | | 0060502626 | 1 | 12200 | | 0060502680 | | 14100 | |
| 0060502529 | 1 | 12020 | | 0060502627 | 1 | 12200 | | 0060502681 | | 14100 | |
| 0060502531 | 1 | 12020 | | 0060502628 | 1 | 12200 | | 0060502682 | | 14100 | |
| 0060502532 | 1 | 12000 | | 0060502629 | 2 | 12200 | | 0060502683 | | 14100 | |
| 0060502533 | 20 | 01200 | | 0060502630 | 1 | 12200 | | 0060502684 | | 14100 | |
| 0060502533 | 19 | 12020 | | 0060502631 | 3 | 12200 | | 0060502685 | | 14100 | |
| 0060502535 | 1 | 12000 | | 0060502632 | 1 | 12200 | | 0060502686 | | 14100 | |
| 0060502536 | 1 | 12000 | | 0060502633 | 1 | 12200 | | 0060502687 | | 14100 | |
| 0060502537 | 2 | 12000 | | 0060502634 | 1 | 12200 | | 0060502688 | | 14100 | |
| 0060502538 | 2 | 12000 | | 0060502635 | 1 | 12200 | | 0060502689 | | 14100 | |
| 0060502539 | 2 | 12000 | | 0060502637 | 1 | 12200 | | 0060502690 | | 14100 | |
| 0060502543 | 1 | 12000 | | 0060502638 | 5 | 12200 | | 0060502691 | | 14100 | |
| 0060502544 | 1 | 12000 | | 0060502639 | 3 | 12200 | | 0060502692 | | 14100 | |
| 0060502545 | 1 | 12000 | | 0060502640 | 1 | 12200 | | 0060502693 | | 14100 | |
| 0060502550 | 1 | 12020 | | 0060502641 | 1 | 12220 | | 0060502694 | | 14100 | |
| 0060502551 | 1 | 12000 | | 0060502641 | 1 | 12221 | | 0060502695 | | 14100 | |
| 0060502554 | 1 | 12000 | | 0060502642 | 1 | 12220 | | 0060502696 | | 14300 | |
| 0060502556 | 1 | 12120 | | 0060502642 | 1 | 12221 | | 0060502697 | | 14300 | |
| 0060502557 | 2 | 12160 | | 0060502644 | 1 | 12220 | | 0060502698 | 2 | 14300 | |
| 0060502557 | 3 | 12161 | | 0060502645 | 1 | 12220 | | 0060502699 | 1 | 14300 | |
| 0060502558 | 1 | 12160 | | 0060502645 | 1 | 12221 | | 0060502700 | 1 | 14300 | |
| 0060502559 | 5 | 12160 | | 0060502646 | 1 | 12220 | | 0060502702 | 1 | 14100 | |
| 0060502559 | 5 | 12161 | | 0060502647 | 1 | 12220 | | 0060502703 | 2 | 14100 | |
| 0060502560 | 7 | 12160 | | 0060502648 | 1 | 12220 | | 0060502706 | 2 | 14300 | |
| 0060502560 | 7 | 12161 | | 0060502648 | 1 | 12221 | | 0060502706 | 1 | 32060 | |
| 0060502561 | 4 | 12160 | | 0060502651 | 1 | 12220 | | 0060502709 | 8 | 14100 | |
| 0060502561 | 4 | 12161 | | 0060502651 | 1 | 12221 | | 0060502711 | | 14300 | |
| 0060502562 | 3 | 12160 | | 0060502652 | 1 | 12220 | | 0060502712 | | 14300 | |
| 0060502562 | 3 | 12161 | | 0060502652 | 1 | 12221 | | 0060502713 | | 14300 | |

INDICE NUMERICO AL BOLLETT. N 01033 DEL CATALOGO S 32

| CATEGORICO | Q. | COD. TAV. | C. SOSTITUENTE M. | CATEGORICO | Q. | COD. TAV. | C. SOSTITUENTE M. | CATEGORICO | Q. | COD. TAV. | C. SOSTITUENTE M. |
|------------|----|-----------|-------------------|------------|----|-----------|-------------------|------------|----|-----------|-------------------|
| 0060502714 | | 14300 | | 0060502902 | 2 | 01310 | | 0060502954 | 1 | 01060 | |
| 0060502715 | | 14300 | | 0060502902 | 2 | 01311 | | 0060502954 | 1 | 01060 | |
| 0060502716 | | 14300 | | 0060502902 | 2 | 01315 | | 0060502956 | 1 | 01310 | |
| 0060502717 | | 14300 | | 0060502907 | 1 | 03100 | | 0060502956 | 1 | 01311 | |
| 0060502718 | | 14300 | | 0060502909 | 1 | 04000 | | 0060502956 | 1 | 01315 | |
| 0060502719 | | 14300 | | 0060502909 | 1 | 04001 | | 0060502957 | 1 | 02031 | |
| 0060502731 | 2 | 14100 | | 0060502911 | 8 | 01420 | | 0060502958 | 8 | 01420 | |
| 0060502732 | 1 | 14100 | | 0060502911 | 8 | 01421 | | 0060502959 | 1 | 01420 | |
| 0060502734 | 1 | 14100 | | 0060502912 | 8 | 01420 | | 0060502961 | 1 | 02030 | |
| 0060502766 | 1 | 32060 | | 0060502912 | 8 | 01421 | | 0060502961 | 1 | 02035 | |
| 0060502767 | 1 | 32060 | | 0060502913 | 2 | 01090 | | 0060502962 | 1 | 01060 | |
| 0060502770 | 1 | 32060 | | 0060502913 | 2 | 01091 | | 0060502962 | 1 | 01065 | |
| 0060502771 | 2 | 32250 | | 0060502916 | 2 | 01090 | | 0060502963 | 1 | 01060 | |
| 0060502772 | 1 | 32060 | | 0060502916 | 2 | 01091 | | 0060502966 | 1 | 02600 | |
| 0060502773 | 2 | 32250 | | 0060502917 | 1 | 01310 | | 0060502966 | 1 | 02601 | |
| 0060502774 | 1 | 32060 | | 0060502917 | 1 | 01311 | | 0060502966 | 1 | 02605 | |
| 0060502775 | 1 | 32060 | | 0060502917 | 1 | 01315 | | 0060502967 | 4 | 02115 | |
| 0060502776 | 1 | 32060 | | 0060502918 | 1 | 01310 | | 0060502967 | 3 | 04100 | |
| 0060502777 | 1 | 32060 | | 0060502918 | 1 | 01311 | | 0060502967 | 3 | 04105 | |
| 0060502778 | 4 | 32060 | | 0060502918 | 1 | 01315 | | 0060502970 | 2 | 04110 | |
| 0060502779 | 2 | 32050 | | 0060502922 | 2 | 01400 | | 0060502970 | 2 | 04111 | |
| 0060502781 | 2 | 32060 | | 0060502922 | 2 | 01401 | | 0060502970 | 2 | 04115 | |
| 0060502784 | 1 | 32060 | | 0060502922 | 2 | 01405 | | 0060502973 | 1 | 04110 | |
| 0060502785 | 1 | 32060 | | 0060502924 | 1 | 12000 | | 0060502973 | 1 | 04111 | |
| 0060502786 | 1 | 32060 | | 0060502925 | | 14100 | | 0060502973 | 1 | 04115 | |
| 0060502790 | 2 | 32250 | | 0060502926 | | 14100 | | 0060502974 | 1 | 02800 | |
| 0060502791 | 1 | 32250 | | 0060502927 | | 14100 | | 0060502974 | 1 | 02805 | |
| 0060502792 | 1 | 32060 | | 0060502928 | | 14100 | | 0060502984 | 4 | 02840 | |
| 0060502793 | 1 | 32060 | | 0060502929 | | 14100 | | 0060502984 | 4 | 02841 | |
| 0060502794 | 1 | 32060 | | 0060502930 | | 14100 | | 0060502984 | 4 | 02845 | |
| 0060502795 | 1 | 32060 | | 0060502931 | | 14100 | | 0060502987 | 1 | 02701 | |
| 0060502798 | 1 | 32060 | | 0060502932 | | 14100 | | 0060502987 | 1 | 02702 | |
| 0060502799 | 1 | 32060 | | 0060502934 | 2 | 02030 | | 0060502989 | 1 | 04110 | |
| 0060502801 | 1 | 32060 | | 0060502934 | 2 | 02035 | | 0060502989 | 1 | 04111 | |
| 0060502890 | 2 | 01010 | | 0060502936 | 2 | 04100 | | 0060502994 | 1 | 01060 | |
| 0060502891 | 1 | 01040 | | 0060502936 | 2 | 04105 | | 0060502994 | 1 | 01065 | |
| 0060502892 | 1 | 01060 | | 0060502937 | 1 | 04100 | | 0060502995 | 1 | 01060 | |
| 0060502892 | 1 | 01065 | | 0060502937 | 1 | 04105 | | 0060502995 | 1 | 01065 | |
| 0060502893 | 1 | 01060 | | 0060502938 | 2 | 04100 | | 0060502996 | 8 | 01080 | |
| 0060502893 | 1 | 01065 | | 0060502938 | 2 | 04105 | | 0060502996 | 8 | 01081 | |
| 0060502896 | 1 | 01310 | | 0060502940 | 4 | 02115 | | 0060503001 | 12 | 01090 | |
| 0060502896 | 1 | 01311 | | 0060502940 | 3 | 04100 | | 0060503001 | 12 | 01091 | |
| 0060502896 | 1 | 01315 | | 0060502940 | 3 | 04105 | | 0060503002 | 2 | 01400 | |
| 0060502897 | 1 | 01310 | | 0060502942 | 1 | 04000 | | 0060503003 | 4 | 01400 | |
| 0060502897 | 1 | 01311 | | 0060502942 | 1 | 04001 | | 0060503003 | 4 | 01401 | |
| 0060502897 | 1 | 01315 | | 0060502950 | 1 | 41000 | | 0060503003 | 4 | 01405 | |
| 0060502898 | 1 | 01310 | | 0060502950 | 1 | 41006 | | 0060503003 | 2 | 04100 | |
| 0060502898 | 1 | 01311 | | 0060502953 | 2 | 01060 | | 0060503003 | 2 | 04105 | |
| 0060502898 | 1 | 01315 | | 0060502953 | 1 | 01065 | | 0060503005 | 1 | 41000 | |

INDICE NUMERICO AL BOLLETT. N 01033 DEL CATALOGO S 32

| CATEGORICO | Q. | COD. TAV. | C. SOSTITUENTE M. | CATEGORICO | Q. | COD. TAV. | C. SOSTITUENTE M. | CATEGORICO | Q. | COD. TAV. | C. SOSTITUENTE M. |
|------------|----|-----------|-------------------|------------|----|-----------|-------------------|------------|----|-----------|-------------------|
| 0060503005 | 1 | 41006 | | 0060503101 | 8 | 01420 | | 0060503297 | 1 | 01060 | |
| 0060503006 | 6 | 01310 | | 0060503102 | 1 | 42010 | | 0060503303 | 2 | 01090 | |
| 0060503006 | 6 | 01311 | | 0060503102 | 1 | 42050 | | 0060503309 | 1 | 03100 | |
| 0060503006 | 6 | 01315 | | 0060503104 | 1 | 02600 | | 0060503395 | 1 | 04100 | |
| 0060503007 | 2 | 01090 | | 0060503105 | 1 | 02600 | | 0060503395 | 1 | 04105 | |
| 0060503007 | 2 | 01091 | | 0060503106 | 1 | 04100 | | 0060503398 | 1 | 02340 | |
| 0060503011 | 1 | 02600 | | 0060503106 | 1 | 04105 | | 0060503398 | 2 | 21003 | |
| 0060503011 | 1 | 02601 | | 0060503111 | 1 | 02040 | | 0060503405 | 8 | 01420 | |
| 0060503011 | 1 | 02605 | | 0060503117 | 1 | 04110 | | 0060503408 | | 01420 | |
| 0060503013 | 1 | 02600 | | 0060503117 | 1 | 04111 | | 0060503409 | | 01420 | |
| 0060503013 | 1 | 02601 | | 0060503117 | 1 | 04115 | | 0060503410 | | 01420 | |
| 0060503014 | 1 | 41000 | | 0060503119 | 1 | 02701 | | 0060503411 | | 01420 | |
| 0060503014 | 1 | 41006 | | 0060503119 | 1 | 02702 | | 0060503412 | | 01420 | |
| 0060503015 | 1 | 41000 | | 0060503128 | 1 | 01310 | | 0060503413 | | 01420 | |
| 0060503015 | 1 | 41006 | | 0060503128 | 1 | 01311 | | 0060503414 | | 01420 | |
| 0060503017 | 1 | 02600 | | 0060503128 | 1 | 01315 | | 0060503415 | | 01420 | |
| 0060503017 | 3 | 02601 | | 0060503147 | 1 | 02045 | | 0060503416 | | 01420 | |
| 0060503019 | 2 | 02701 | | 0060503148 | 4 | 01310 | | 0060503417 | | 01420 | |
| 0060503019 | 2 | 02702 | | 0060503148 | 4 | 01311 | | 0060503418 | | 01420 | |
| 0060503019 | 1 | 02800 | | 0060503148 | 4 | 01315 | | 0060503419 | | 01420 | |
| 0060503019 | 1 | 02805 | | 0060503149 | 8 | 01310 | | 0060503420 | | 01420 | |
| 0060503028 | 2 | 01310 | | 0060503149 | 8 | 01311 | | 0060503421 | | 01420 | |
| 0060503028 | 2 | 01311 | | 0060503149 | 8 | 01315 | | 0060503422 | | 01420 | |
| 0060503028 | 2 | 01315 | | 0060503151 | 1 | 02040 | | 0060503423 | | 01420 | |
| 0060503029 | 6 | 01010 | | 0060503152 | 1 | 02040 | | 0060503424 | | 01420 | |
| 0060503033 | 4 | 02840 | | 0060503155 | 1 | 01060 | | 0060503425 | | 01420 | |
| 0060503033 | 4 | 02841 | | 0060503155 | 1 | 01065 | | 0060503426 | | 01420 | |
| 0060503033 | 4 | 02845 | | 0060503156 | 4 | 41000 | | 0060503427 | | 01420 | |
| 0060503034 | 1 | 01060 | | 0060503165 | 2 | 01090 | | 0060503428 | | 01420 | |
| 0060503034 | 1 | 01065 | | 0060503168 | 1 | 03100 | | 0060503429 | | 01420 | |
| 0060503036 | 16 | 01420 | | 0060503170 | 1 | 03100 | | 0060503430 | | 01420 | |
| 0060503036 | 16 | 01421 | | 0060503172 | 1 | 03100 | | 0060503431 | | 01420 | |
| 0060503038 | 2 | 01310 | | 0060503175 | 1 | 04110 | | 0060503432 | | 01420 | |
| 0060503039 | 8 | 01420 | | 0060503175 | 1 | 04111 | | 0060503433 | | 01420 | |
| 0060503067 | 2 | 02805 | | 0060503175 | 1 | 04115 | | 0060503434 | | 01420 | |
| 0060503075 | 1 | 01200 | | 0060503200 | 2 | 02030 | | 0060503435 | | 01420 | |
| 0060503078 | 1 | 01040 | | 0060503200 | 2 | 02035 | | 0060503436 | | 01420 | |
| 0060503080 | | 04060 | | 0060503290 | 3 | 01310 | | 0060503451 | 3 | 04115 | |
| 0060503080 | | 04001 | | 0060503290 | 3 | 01311 | | 0060503455 | | 02640 | |
| 0060503083 | 1 | 02110 | | 0060503290 | 3 | 01315 | | 0060503518 | 2 | 02640 | |
| 0060503084 | 1 | 02110 | | 0060503291 | 1 | 01400 | | 0060503584 | 2 | 01401 | |
| 0060503085 | 1 | 02110 | | 0060503291 | 1 | 01401 | | 0060503584 | 2 | 01405 | |
| 0060503086 | 1 | 02110 | | 0060503291 | 1 | 01405 | | 0060503668 | 1 | 01311 | |
| 0060503086 | 1 | 02114 | | 0060503292 | 2 | 01400 | | 0060503668 | 1 | 01315 | |
| 0060503092 | 1 | 02600 | | 0060503292 | 2 | 01401 | | 0060503683 | 6 | 02030 | |
| 0060503092 | 1 | 02601 | | 0060503292 | 2 | 01405 | | 0060503683 | 6 | 02035 | |
| 0060503092 | 1 | 02605 | | 0060503295 | 8 | 01310 | | 0060503687 | 1 | 04100 | |
| 0060503093 | 1 | 01040 | | 0060503295 | 8 | 01311 | | 0060503687 | 1 | 04105 | |
| 0060503099 | 2 | 01090 | | 0060503295 | 8 | 01315 | | 0060503741 | 2 | 04100 | |

INDICE NUMERICO AL BOLLETT. N 01033 DEL CATALOGO S 32

| CATEGORICO | Q. | COD. TAV. | C. SOSTITUENTE M. | CATEGORICO | Q. | COD. TAV. | C. SOSTITUENTE M. | CATEGORICO | Q. | COD. TAV. | C. SOSTITUENTE M. |
|------------|----|-----------|-------------------|------------|----|-----------|-------------------|------------|----|-----------|-------------------|
| 0060503741 | 2 | 04105 | | 0060504305 | 1 | 02701 | | 0060504787 | 2 | 01090 | |
| 0060503819 | 6 | 21000 | | 0060504306 | 1 | 02600 | | 0060504790 | 1 | 02400 | |
| 0060503819 | 6 | 21003 | | 0060504307 | 1 | 02030 | | 0060504791 | 1 | 02460 | |
| 0060503819 | 6 | 21005 | | 0060504307 | 1 | 02035 | | 0060504792 | 1 | 02400 | |
| 0060503916 | 2 | 01090 | | 0060504309 | 1 | 04111 | | 0060504793 | 1 | 02460 | |
| 0060503916 | 1 | 01091 | | 0060504323 | | 41000 | | 0060504798 | 2 | 02603 | |
| 0060503993 | 4 | 01420 | | 0060504325 | 1 | 41000 | | 0060504799 | 1 | 02603 | |
| 0060504110 | 8 | 01420 | | 0060504325 | 1 | 41001 | | 0060504800 | 2 | 02603 | |
| 0060504110 | 8 | 01421 | | 0060504326 | 1 | 41001 | | 0060504802 | 2 | 02603 | |
| 0060504180 | 1 | 02030 | | 0060504327 | 1 | 02030 | | 0060504811 | 1 | 02600 | |
| 0060504188 | 1 | 02030 | | 0060504336 | 1 | 41001 | | 0060504811 | 1 | 02601 | |
| 0060504190 | 1 | 01060 | | 0060504337 | 1 | 41001 | | 0060504812 | 2 | 02603 | |
| 0060504190 | 1 | 01065 | | 0060504357 | 1 | 03100 | | 0060504813 | 2 | 02603 | |
| 0060504193 | 1 | 01060 | | 0060504358 | 1 | 03100 | | 0060504816 | 1 | 41210 | |
| 0060504195 | 1 | 04110 | | 0060504365 | 1 | 02840 | | 0060504818 | 1 | 41280 | |
| 0060504195 | 1 | 04111 | | 0060504375 | 1 | 01080 | | 0060504821 | 1 | 41000 | |
| 0060504209 | 1 | 02840 | | 0060504375 | 1 | 01081 | | 0060504823 | 2 | 41000 | |
| 0060504209 | 1 | 02841 | | 0060504378 | 1 | 02840 | | 0060504825 | 2 | 41000 | |
| 0060504209 | 1 | 02845 | | 0060504378 | 1 | 02841 | | 0060504825 | 2 | 41006 | |
| 0060504214 | 1 | 02110 | | 0060504378 | 1 | 02845 | | 0060504827 | 1 | 43010 | |
| 0060504215 | 1 | 04110 | | 0060504379 | 1 | 02840 | | 0060504827 | 1 | 43030 | |
| 0060504215 | 1 | 04111 | | 0060504379 | 1 | 02841 | | 0060504827 | 1 | 43050 | |
| 0060504215 | 1 | 04115 | | 0060504386 | 1 | 04100 | | 0060504829 | 1 | 04001 | |
| 0060504218 | 1 | 42010 | | 0060504386 | 1 | 04105 | | 0060504830 | 1 | 04000 | |
| 0060504218 | 1 | 42050 | | 0060504407 | 1 | 04000 | | 0060504831 | 1 | 04000 | |
| 0060504218 | 1 | 42080 | | 0060504407 | 1 | 04001 | | 0060504831 | 1 | 04001 | |
| 0060504219 | 1 | 42050 | | 0060504419 | 1 | 43011 | | 0060504832 | 7 | 01040 | |
| 0060504220 | 1 | 01400 | | 0060504524 | 1 | 01200 | | 0060504835 | 1 | 04000 | |
| 0060504221 | 1 | 01400 | | 0060504540 | 1 | 01200 | | 0060504835 | 1 | 04001 | |
| 0060504222 | 1 | 01400 | | 0060504550 | 1 | 01310 | | 0060504838 | 1 | 02800 | |
| 0060504223 | 1 | 01400 | | 0060504563 | 4 | 41000 | | 0060504838 | 1 | 02805 | |
| 0060504224 | 1 | 01400 | | 0060504563 | 4 | 41001 | | 0060504841 | 1 | 02800 | |
| 0060504224 | 1 | 01401 | | 0060504563 | 4 | 41006 | | 0060504841 | 1 | 02805 | |
| 0060504224 | 1 | 01405 | | 0060504668 | 2 | 01310 | | 0060504842 | 1 | 02800 | |
| 0060504225 | 1 | 01400 | | 0060504673 | 1 | 12161 | | 0060504842 | 1 | 02805 | |
| 0060504225 | 1 | 01401 | | 0060504676 | 1 | 14100 | | 0060504843 | 1 | 02800 | |
| 0060504225 | 1 | 01405 | | 0060504686 | 6 | 14400 | | 0060504843 | 1 | 02805 | |
| 0060504232 | 2 | 41000 | | 0060504713 | 1 | 11500 | | 0060504847 | 1 | 02800 | |
| 0060504238 | 1 | 02030 | | 0060504718 | 2 | 14400 | | 0060504849 | 4 | 02800 | |
| 0060504238 | 1 | 02035 | | 0060504723 | 1 | 12220 | | 0060504850 | 1 | 02800 | |
| 0060504284 | 1 | 01060 | | 0060504725 | 1 | 12220 | | 0060504851 | 2 | 02800 | |
| 0060504284 | 1 | 01065 | | 0060504726 | 1 | 12220 | | 0060504851 | 2 | 02805 | |
| 0060504286 | 4 | 01310 | | 0060504727 | 1 | 12220 | | 0060504852 | 1 | 02701 | |
| 0060504286 | 4 | 01311 | | 0060504733 | 1 | 31011 | | 0060504852 | 1 | 02702 | |
| 0060504286 | 4 | 01315 | | 0060504736 | 1 | 31011 | | 0060504855 | 1 | 02701 | |
| 0060504288 | 1 | 41001 | | 0060504750 | 2 | 31110 | | 0060504855 | 1 | 02702 | |
| 0060504289 | 1 | 41001 | | 0060504755 | 2 | 01080 | | 0060504856 | 2 | 02702 | |
| 0060504299 | 1 | 02840 | | 0060504783 | 4 | 01420 | | 0060504860 | 2 | 02701 | |
| 0060504302 | 1 | 02840 | | 0060504784 | 4 | 01420 | | 0060504860 | 2 | 02702 | |

INDICE NUMERICO AL BOLLETT. N 01033 DEL CATALOGO S 32

| CATEGORICO | Q. | COD. TAV. | C. SOSTITUENTE M. | CATEGORICO | Q. | COD. TAV. | C. SOSTITUENTE M. | CATEGORICO | Q. | COD. TAV. | C. SOSTITUENTE M. |
|------------|----|-----------|-------------------|------------|----|-----------|-------------------|------------|----|-----------|-------------------|
| 0060504861 | 2 | 02701 | | 0060513205 | 1 | 02805 | | 0060515408 | 1 | 01200 | |
| 0060504861 | 2 | 02702 | | 0060513940 | 8 | 01421 | | 0060515461 | 1 | 32110 | |
| 0060504862 | 1 | 02701 | | 0060513941 | 1 | 01421 | | 0060515493 | 1 | 01200 | |
| 0060504866 | 1 | 02701 | | 0060514871 | 1 | 11500 | | 0060515587 | 1 | 14100 | |
| 0060504866 | 1 | 02702 | | 0060514881 | 2 | 21501 | | 0060515592 | 1 | 32110 | |
| 0060504867 | 2 | 02701 | | 0060514835 | 1 | 21615 | | 0060515595 | 2 | 31120 | |
| 0060504867 | 2 | 02702 | | 0060514890 | 1 | 21615 | | 0060515604 | | 12300 | |
| 0060504868 | 2 | 02701 | | 0060514905 | 2 | 01081 | | 0060515656 | 1 | 04110 | |
| 0060504868 | 2 | 02702 | | 0060514910 | 2 | 01091 | | 0060515656 | 1 | 04111 | |
| 0060504869 | 1 | 02701 | | 0060514975 | 2 | 21000 | | 0060515656 | 1 | 04115 | |
| 006050486C | 1 | 02702 | | 0060514976 | 1 | 02735 | | 0060515658 | 1 | 12120 | |
| 0060504870 | 1 | 02701 | | 0060514976 | 2 | 21000 | | 0060515666 | | 12300 | |
| 0060504870 | 1 | 02702 | | 0060514986 | 1 | 21521 | | 0060515667 | | 12300 | |
| 0060504975 | | 31200 | | 0060514987 | 1 | 21521 | | 0060515681 | 1 | 21000 | |
| 0060505003 | 1 | 21720 | | 0060514991 | 1 | 14100 | | 0060515684 | 1 | 21000 | |
| 0060505017 | 1 | 31070 | | 0060515006 | 5 | 31200 | | 0060515694 | 1 | 01310 | |
| 0060505018 | 2 | 31070 | | 0060515008 | 1 | 21850 | | 0060515697 | 1 | 41000 | |
| 0060505020 | 2 | 31070 | | 0060515018 | 8 | 01321 | | 0060515697 | 1 | 41000 | |
| 0060505021 | 2 | 31070 | | 0060515018 | 8 | 01325 | | 0060515705 | 1 | 32060 | |
| 0060505029 | 2 | 31110 | | 0060515019 | 8 | 01321 | | 0060515708 | 1 | 32110 | |
| 0060505310 | 1 | 14100 | | 0060515019 | 8 | 01325 | | 0060517044 | 1 | 02350 | |
| 0060505797 | 1 | 31010 | | 0060515021 | 1 | 01311 | | 0060517102 | 1 | 02036 | |
| 0060506411 | 1 | 02355 | | 0060515034 | 2 | 01401 | | 0060517421 | 1 | 02036 | |
| 0060506411 | 1 | 04105 | | 0060515034 | 2 | 01405 | | 0060517428 | 2 | 32110 | |
| 0060506548 | 4 | 01420 | | 0060515036 | 1 | 01400 | | 0060517440 | 1 | 01065 | |
| 0060506562 | 1 | 02701 | | 0060515036 | 1 | 01401 | | 0060517441 | 1 | 32110 | |
| 0060506562 | 2 | 02841 | | 0060515036 | 1 | 01405 | | 0060517474 | 1 | 04100 | |
| 0060506562 | 2 | 02845 | | 0060515037 | 1 | 01400 | | 0060517474 | 1 | 04105 | |
| 0060506664 | 1 | 21850 | | 0060515037 | 1 | 01401 | | 0060517476 | 1 | 02037 | |
| 0060506760 | 1 | 02040 | | 0060515037 | 1 | 01405 | | 0060517483 | 1 | 02845 | |
| 0060506764 | 1 | 04110 | | 0060515041 | 4 | 01421 | | 0060517489 | 1 | 12000 | |
| 0060506764 | 1 | 04111 | | 0060515042 | 4 | 01421 | | 0060517512 | | 01400 | |
| 0060506766 | 1 | 04110 | | 0060515044 | 8 | 01421 | | 0060517513 | 2 | 01400 | |
| 0060506766 | 1 | 04111 | | 0060515045 | 8 | 01421 | | 0060517608 | 1 | 02800 | |
| 0060506768 | 1 | 04111 | | 0060515047 | 8 | 01421 | | 0060517611 | 1 | 02600 | |
| 0060506769 | 1 | 04110 | | 0060515051 | 1 | 01401 | | 0060517611 | 1 | 02601 | |
| 0060506769 | 1 | 04111 | | 0060515051 | 1 | 01405 | | 0060517617 | 2 | 02701 | |
| 0060506769 | 1 | 04115 | | 0060515052 | 1 | 01401 | | 0060517620 | 1 | 02600 | |
| 0060506799 | 1 | 02640 | | 0060515052 | 1 | 01405 | | 0060517620 | 1 | 02601 | |
| 0060506803 | 1 | 02600 | | 0060515053 | 2 | 01401 | | 0060517621 | 1 | 02600 | |
| 0060506897 | 2 | 02350 | | 0060515054 | 1 | 01401 | | 0060517621 | 1 | 02601 | |
| 0060507004 | 1 | 02116 | | 0060515054 | 1 | 01405 | | 0060517625 | 1 | 04000 | |
| 0060507127 | 1 | 02037 | | 0060515055 | 1 | 01401 | | 0060517625 | 1 | 04001 | |
| 0060507128 | 1 | 02115 | | 0060515055 | 1 | 01405 | | 0060517640 | 1 | 04110 | |
| 0060507263 | 1 | 02605 | | 0060515057 | 1 | 02403 | | 0060517641 | 1 | 04110 | |
| 0060507355 | 4 | 02060 | | 0060515059 | 1 | 02461 | | 0060517641 | 1 | 04111 | |
| 0060507656 | 1 | 02361 | | 0060515060 | 1 | 02461 | | 0060517642 | 1 | 02600 | |
| 0060512672 | 1 | 02350 | | 0060515390 | 1 | 21523 | | 0060517642 | 1 | 02601 | |
| 0060513187 | 1 | 02330 | | 0060515393 | 1 | 21523 | | 0060517643 | 2 | 02800 | |

INDICE NUMERICO AL BOLLETT. N 01033 DEL CATALOGO S 32

| CATEGORICO | Q. | COD. TAV. | C. SOSTITUENTE M. | CATEGORICO | Q. | COD. TAV. | C. SOSTITUENTE M. | CATEGORICO | Q. | COD. TAV. | C. SOSTITUENTE M. |
|------------|----|-----------|-------------------|------------|----|-----------|-------------------|------------|----|-----------|-------------------|
| 0060517644 | 2 | 02800 | | 0060518739 | 1 | 02350 | | 0060525070 | 3 | 02330 | |
| 0060517645 | 2 | 02800 | | 0060521557 | 1 | 02114 | | 0060525071 | 2 | 02330 | |
| 0060517646 | 8 | 02800 | | 0060521967 | 8 | 14300 | | 0060525072 | 1 | 02061 | |
| 0060517647 | 1 | 02800 | | 0060522476 | 1 | 02031 | | 0060525074 | 6 | 02330 | |
| 0060517648 | 1 | 01320 | | 0060522477 | 1 | 02031 | | 0060525075 | 1 | 02605 | |
| 0060517649 | 1 | 01320 | | 0060522648 | 1 | 02115 | | 0060525089 | 1 | 02060 | |
| 0060517650 | 1 | 01320 | | 0060523124 | 1 | 02605 | | 0060525089 | 1 | 02350 | |
| 0060517651 | 1 | 01320 | | 0060523389 | 1 | 02330 | | 0060525132 | 1 | 02737 | |
| 0060517652 | 1 | 01320 | | 0060523650 | 1 | 32100 | | 0060525133 | 1 | 04115 | |
| 0060517654 | 1 | 01320 | | 0060523696 | 1 | 02037 | | 0060525134 | 1 | 04115 | |
| 0060517682 | 1 | 02701 | | 0060523701 | 2 | 02037 | | 0060525136 | 1 | 04115 | |
| 0060517682 | 1 | 02702 | | 0060523722 | 1 | 02701 | | 0060525137 | 1 | 04115 | |
| 0060517690 | 4 | 02701 | | 0060523722 | 1 | 02845 | | 0060525138 | 1 | 04115 | |
| 0060517690 | 4 | 02702 | | 0060523730 | 7 | 02040 | | 0060525139 | 1 | 02330 | |
| 0060517693 | 1 | 02031 | | 0060523733 | 1 | 32100 | | 0060525140 | 1 | 02737 | |
| 0060517696 | 1 | 02603 | | 0060523734 | 1 | 32100 | | 0060525143 | 2 | 02350 | |
| 0060517699 | 1 | 02031 | | 0060523753 | 1 | 32100 | | 0060525160 | 6 | 02045 | |
| 0060517699 | 1 | 02036 | | 0060523798 | 1 | 02037 | | 0060525170 | 1 | 02735 | |
| 0060517700 | 1 | 02031 | | 0060523908 | 1 | 32110 | | 0060525187 | 2 | 02045 | |
| 0060517703 | 1 | 02031 | | 0060524067 | 1 | 21710 | | 0060525193 | 1 | 01065 | |
| 0060517704 | 1 | 02031 | | 0060524132 | 1 | 21501 | | 0060525196 | 1 | 01065 | |
| 0060517705 | 1 | 02031 | | 0060524133 | 1 | 21501 | | 0060525203 | 1 | 02045 | |
| 0060517707 | 1 | 02702 | | 0060524145 | 1 | 02845 | | 0060525234 | 1 | 02355 | |
| 0060517708 | 1 | 02040 | | 0060524146 | 1 | 02845 | | 0060525356 | 1 | 02037 | |
| 0060517708 | 2 | 04110 | | 0060524146 | 1 | 04115 | | 0060525464 | 1 | 02705 | |
| 0060517708 | 1 | 04111 | | 0060524273 | 1 | 02037 | | 0060525465 | 2 | 02705 | |
| 0060517708 | 1 | 04115 | | 0060524483 | 1 | 21000 | | 0060525488 | 1 | 02640 | |
| 0060517714 | 1 | 04000 | | 0060524516 | 1 | 02702 | | 0060525488 | 1 | 32100 | |
| 0060517714 | 1 | 04001 | | 0060524520 | 1 | 02061 | | 0060525551 | 1 | 02045 | |
| 0060517720 | 4 | 31200 | | 0060524521 | 1 | 02737 | | 0060525560 | 1 | 02045 | |
| 0060517725 | 1 | 02601 | | 0060524526 | 1 | 02702 | | 0060525616 | 1 | 02045 | |
| 0060518164 | 1 | 02735 | | 0060524529 | 4 | 02060 | | 0060525640 | 1 | 02350 | |
| 0060518426 | | 14300 | | 0060524534 | 8 | 02800 | | 0060525879 | 1 | 12120 | |
| 0060518427 | | 14300 | | 0060524535 | 2 | 02800 | | 0060526036 | 2 | 01060 | |
| 0060518428 | | 14300 | | 0060524623 | 1 | 02036 | | 0060526036 | 2 | 01065 | |
| 0060518429 | | 14300 | | 0060524624 | 1 | 02036 | | 0060526036 | 2 | 12020 | |
| 0060518430 | | 14300 | | 0060524625 | 1 | 02036 | | 0060531065 | 1 | 02735 | |
| 0060518431 | | 14300 | | 0060524626 | 1 | 02036 | | 0060533057 | 4 | 31200 | |
| 0060518432 | | 14300 | | 0060524647 | 1 | 02036 | | 0060535940 | 2 | 21600 | |
| 0060518433 | | 14300 | | 0060524670 | 1 | 02115 | | 0060535941 | 2 | 21600 | |
| 0060518436 | 1 | 32100 | | 0060524717 | 2 | 02350 | | 0060535943 | | 12300 | |
| 0060518443 | 1 | 02031 | | 0060524736 | 2 | 31070 | | 0060535944 | | 12300 | |
| 0060518442 | 16 | 31200 | | 0060524895 | 1 | 02702 | | 0060535945 | 1 | 12300 | |
| 0060518443 | 1 | 01320 | | 0060524917 | 1 | 02350 | | 0060535949 | 8 | 01420 | |
| 0060518444 | 1 | 01320 | | 0060525003 | 1 | 02605 | | 0060536032 | 1 | 32110 | |
| 0060518448 | 3 | 21710 | | 0060525020 | 1 | 02601 | | 0060536036 | 1 | 02600 | |
| 0060518683 | 1 | 02350 | | 0060525020 | 1 | 02605 | | 0060536036 | 1 | 02601 | |
| 0060518686 | 1 | 02350 | | 0060525021 | 1 | 02601 | | 0060536036 | 1 | 02605 | |
| 0060518738 | 1 | 02350 | | 0060525049 | 1 | 02116 | | 0060536055 | 1 | 04000 | |

INDICE NUMERICO AL BOLLETT. N 01033 DEL CATALOGO S 32

| CATEGORICO | Q. | COD. TAV. | C. SOSTITUENTE M. | CATEGORICO | Q. | COD. TAV. | C. SOSTITUENTE M. | CATEGORICO | Q. | COD. TAV. | C. SOSTITUENTE M. |
|------------|----|-----------|-------------------|------------|----|-----------|-------------------|------------|----|-----------|-------------------|
| 0060536055 | 1 | 04001 | | 0060537605 | 1 | 02115 | | 0060538511 | 1 | 02330 | |
| 0060536104 | 1 | 04110 | | 0060537608 | 1 | 21521 | | 0060538512 | 1 | 01065 | |
| 0060536104 | 1 | 04115 | | 0060537609 | 1 | 21521 | | 0060538523 | 1 | 41006 | |
| 0060536124 | 1 | 41001 | | 0060537610 | 1 | 41001 | | 0060538559 | 1 | 02045 | |
| 0060536148 | 1 | 04100 | | 0060537610 | 1 | 41006 | | 0060538562 | 1 | 02045 | |
| 0060536148 | 1 | 04105 | | 0060537611 | 1 | 02115 | | 0060538563 | 1 | 02045 | |
| 0060536160 | 1 | 32110 | | 0060537647 | 1 | 02605 | | 0060538564 | 1 | 02045 | |
| 0060536182 | 1 | 01310 | | 0060537650 | 1 | 02845 | | 0060538565 | 1 | 02037 | |
| 0060536202 | 4 | 41000 | | 0060537671 | 2 | 01081 | | 0060538631 | 1 | 02735 | |
| 0060536202 | 4 | 41006 | | 0060537676 | 1 | 02841 | | 0060538675 | 1 | 02735 | |
| 0060536220 | 1 | 02800 | | 0060537702 | 1 | 02702 | | 0060538677 | 1 | 02735 | |
| 0060536221 | 1 | 02800 | | 0060537705 | 1 | 02737 | | 0060538923 | 1 | 02700 | |
| 0060536227 | 1 | 02701 | | 0060537743 | 2 | 01080 | | 0060538923 | 1 | 02705 | |
| 0060536228 | 1 | 02701 | | 0060537769 | 1 | 21003 | | 0060539799 | 1 | 02035 | |
| 0060536242 | 1 | 02400 | | 0060537770 | 1 | 21000 | | 0060540536 | 1 | 31011 | |
| 0060536243 | 1 | 02400 | | 0060537771 | 1 | 21000 | | 0060542454 | 2 | 21000 | |
| 0060536275 | 1 | 11500 | | 0060537772 | 1 | 21000 | | 0060542455 | 1 | 21000 | |
| 0060536278 | 1 | 32110 | | 0060537773 | 1 | 21003 | | 0060542457 | 1 | 21000 | |
| 0060536290 | 1 | 32100 | | 0060537774 | 1 | 21003 | | 0060543153 | 4 | 01321 | |
| 0060536299 | 1 | 02640 | | 0060537775 | 1 | 21003 | | 0060543153 | 4 | 01325 | |
| 0060536300 | 1 | 02460 | | 0060537816 | 1 | 02845 | | 0060543154 | 4 | 01321 | |
| 0060536301 | 1 | 02460 | | 0060537817 | 1 | 02845 | | 0060543154 | 4 | 01325 | |
| 0060536305 | 1 | 43050 | | 0060537868 | 2 | 01405 | | 0060543576 | 1 | 41001 | |
| 0060536320 | 1 | 12300 | | 0060537911 | 1 | 02601 | | 0060543578 | 1 | 41210 | |
| 0060536324 | 1 | 12300 | | 0060537915 | 1 | 02601 | | 0060543581 | 8 | 01081 | |
| 0060536406 | 1 | 21000 | | 0060537916 | 1 | 02601 | | 0060543581 | 4 | 01010 | |
| 0060536615 | 1 | 32100 | | 0060537920 | 1 | 02601 | | 0060543581 | 8 | 01080 | |
| 0060536764 | 1 | 02031 | | 0060537941 | 1 | 02845 | | 0060543686 | 1 | 12120 | |
| 0060536768 | 1 | 41280 | | 0060537945 | 2 | 41006 | | 0060700750 | 1 | 02330 | |
| 0060536849 | 1 | 32100 | | 0060537946 | 1 | 41006 | | 0060707716 | 11 | 02040 | |
| 0060536850 | 1 | 02640 | | 0060537971 | 1 | 02605 | | 0060707716 | 5 | 02045 | |
| 0060536862 | 1 | 32100 | | 0060538060 | 1 | 04115 | | 0060707716 | 2 | 02060 | |
| 0060536870 | 1 | 21850 | | 0060538120 | 1 | 02701 | | 0060707717 | 2 | 02330 | |
| 0060536999 | 1 | 32110 | | 0060538120 | 1 | 02702 | | 0060707717 | 3 | 02737 | |
| 0060537000 | 1 | 32110 | | 0060538156 | 1 | 11500 | | 0060707717 | 7 | 04110 | |
| 0060537108 | 1 | 41251 | | 0060538347 | 1 | 21000 | | 0060707717 | 7 | 04111 | |
| 0060537136 | 1 | 02841 | | 0060538400 | 1 | 02705 | | 0060707717 | 7 | 04115 | |
| 0060537246 | 1 | 01040 | | 0060538401 | 1 | 01065 | | 0060707730 | | 02460 | |
| 0060537313 | 2 | 01400 | | 0060538402 | 1 | 02330 | | 0060707730 | 4 | 02461 | |
| 0060537407 | 1 | 11100 | | 0060538404 | 1 | 02705 | | 0060707733 | 1 | 02400 | |
| 0060537453 | 1 | 02841 | | 0060538409 | 1 | 41006 | | 0060709439 | | 14300 | |
| 0060537459 | 1 | 02403 | | 0060538412 | 1 | 02350 | | 0060709440 | | 14300 | |
| 0060537477 | 1 | 02700 | | 0060538413 | 1 | 02350 | | 0060709441 | | 14300 | |
| 0060537494 | 1 | 32100 | | 0060538419 | 1 | 02036 | | 0060709442 | | 14300 | |
| 0060537495 | | 31200 | | 0060538443 | 1 | 01315 | | 0060709443 | | 14300 | |
| 0060537527 | 4 | 02060 | | 0060538456 | 1 | 02735 | | 0060709759 | 1 | 32100 | |
| 0060537528 | 1 | 02061 | | 0060538469 | 1 | 01065 | | 0060709773 | 1 | 32100 | |
| 0060537530 | 1 | 02330 | | 0060538481 | 1 | 02355 | | 0060709774 | 1 | 32100 | |
| 0060537532 | 1 | 02845 | | 0060538507 | 1 | 02037 | | 0060709777 | 2 | 01041 | |

INDICE NUMERICO AL BOLLETT. N 01033 DEL CATALOGO S 32

| CATEGORICO | Q. | COD. TAV. | C. SOSTITUENTE M. | CATEGORICO | Q. | COD. TAV. | C. SOSTITUENTE M. | CATEGORICO | Q. | COD. TAV. | C. SOSTITUENTE M. |
|------------|----|-----------|-------------------|------------|----|-----------|-------------------|------------|----|-----------|-------------------|
| 0060710301 | | 11100 | | 0060729171 | | 02460 | | 0060748298 | | 12161 | |
| 0060710301 | 1 | 11101 | | 0050729171 | 2 | 02461 | | 0060748299 | | 12161 | |
| 0060710301 | | 21100 | | 0060729628 | 1 | 32110 | | 0060748300 | | 12161 | |
| 0060710301 | | 21120 | | 0060732885 | 1 | 43011 | | 0060748302 | 4 | 42010 | |
| 0060710302 | | 11100 | | 0060732887 | 2 | 43010 | | 0060748305 | 1 | 42010 | |
| 0060710302 | | 11101 | | 0060732893 | 1 | 43010 | | 0060748306 | 1 | 42010 | |
| 0060710302 | | 21100 | | 0060735999 | 4 | 43010 | | 0060748310 | 1 | 42010 | |
| 0060710302 | | 21120 | | 0060736004 | 1 | 43010 | | 0060748311 | 1 | 42010 | |
| 0060710303 | | 11100 | | 0060738104 | 1 | 42050 | | 0060748315 | 4 | 42010 | |
| 0060710303 | | 11101 | | 0060738378 | 1 | 02800 | | 0060748320 | 2 | 42010 | |
| 0060710303 | | 21100 | | 0060738470 | 2 | 31120 | | 0060748322 | 2 | 42010 | |
| 0060710303 | | 21120 | | 0060738511 | 4 | 02700 | | 0060748327 | 1 | 43010 | |
| 0060710304 | | 11100 | | 0060738588 | 1 | 11210 | | 0060748327 | 1 | 43011 | |
| 0060710304 | | 11101 | | 0060738590 | 1 | 11210 | | 0060748328 | 1 | 43010 | |
| 0060710304 | | 21100 | | 0060739049 | 4 | 02800 | | 0060748328 | 1 | 43011 | |
| 0060710304 | | 21120 | | 0060744060 | 1 | 32050 | | 0060748353 | 1 | 11310 | |
| 0060711568 | 1 | 41210 | | 0060744061 | 1 | 32050 | | 0060748354 | 1 | 11310 | |
| 0060711578 | 1 | 42010 | | 0060744341 | 1 | 01019 | | 0060748355 | 1 | 11310 | |
| 0060713740 | 3 | 04110 | | 0060744354 | 1 | 01019 | | 0060748358 | 1 | 11210 | |
| 0060713740 | 3 | 04111 | | 0060744356 | 1 | 01019 | | 0060748367 | 4 | 42050 | |
| 0060713740 | 3 | 04115 | | 0060744358 | 1 | 01019 | | 0060748370 | 1 | 42050 | |
| 0060714203 | 1 | 02460 | | 0060744361 | 1 | 01019 | | 0060748390 | 1 | 42050 | |
| 0060714203 | 1 | 02461 | | 0060744363 | 1 | 01019 | | 0060748402 | 1 | 43030 | |
| 0060714225 | | 02460 | | 0060747262 | 1 | 02603 | | 0060748409 | 1 | 42010 | |
| 0060714225 | 3 | 02461 | | 0060748197 | 1 | 02300 | | 0060748412 | 2 | 42010 | |
| 0060714534 | 1 | 11101 | | 0060748198 | 1 | 02800 | | 0060748414 | 2 | 42010 | |
| 0060714536 | 1 | 21120 | | 0060748201 | 1 | 01200 | | 0060748421 | 4 | 43010 | |
| 0060718981 | 1 | 01321 | | 0060748202 | 1 | 11100 | | 0060748583 | 2 | 14400 | |
| 0060723727 | 4 | 02400 | | 0060748209 | 8 | 01080 | | 0060748910 | 1 | 42010 | |
| 0060723735 | 1 | 02400 | | 0060748219 | 2 | 01310 | | 0060748911 | 1 | 42010 | |
| 0060723799 | 1 | 42010 | | 0060748219 | 2 | 01311 | | 0060748917 | 2 | 42010 | |
| 0060723806 | 1 | 42010 | | 0060748219 | 2 | 01315 | | 0060748918 | 1 | 42010 | |
| 0060723808 | 2 | 42010 | | 0060748265 | 4 | 14400 | | 0060748971 | 1 | 42050 | |
| 0060723809 | 2 | 42010 | | 0060748269 | 1 | 11200 | | 0060748972 | 1 | 42050 | |
| 0060723809 | 2 | 43010 | | 0060748270 | 1 | 11200 | | 0060748973 | 1 | 42050 | |
| 0060724033 | 2 | 14400 | | 0060748280 | 1 | 11300 | | 0060748975 | 1 | 42050 | |
| 0060724243 | 1 | 11300 | | 0060748283 | 1 | 11200 | | 0060748976 | 1 | 42050 | |
| 0060724715 | 1 | 42080 | | 0060748284 | 1 | 11200 | | 0060748977 | 1 | 42050 | |
| 0060724998 | 2 | 02400 | | 0060748285 | 1 | 11200 | | 0060748978 | 1 | 42050 | |
| 0060725083 | 1 | 42010 | | 0060748286 | 1 | 11200 | | 0060748979 | 1 | 42050 | |
| 0060725086 | 1 | 42010 | | 0060748287 | 1 | 11300 | | 0060748980 | 1 | 42050 | |
| 0060725100 | | 42050 | | 0060748288 | 1 | 11300 | | 0060748981 | 1 | 42050 | |
| 0060725103 | 1 | 42050 | | 0060748289 | 1 | 11300 | | 0060748982 | 1 | 42050 | |
| 0060725939 | 1 | 43011 | | 0060748292 | | 12161 | | 0060748984 | 1 | 42050 | |
| 0060725940 | 1 | 43010 | | 0060748293 | | 12161 | | 0060748985 | 1 | 42050 | |
| 0060725940 | 1 | 43011 | | 0060748294 | | 12161 | | 0060748986 | 1 | 42050 | |
| 0060725942 | 1 | 43010 | | 0060748295 | | 12161 | | 0060748987 | 1 | 43030 | |
| 0060727983 | | 02460 | | 0060748296 | | 12161 | | 0060748989 | 1 | 43030 | |
| 0060727983 | 2 | 02461 | | 0060748297 | | 12161 | | 0060748991 | 1 | 43030 | |

INDICE NUMERICO AL BOLLETT. N 01033 DEL CATALOGO S 32

| CATEGORICO | Q. | COD. TAV. | C. SOSTITUENTE M. | CATEGORICO | Q. | COD. TAV. | C. SOSTITUENTE M. | CATEGORICO | Q. | COD. TAV. | C. SOSTITUENTE M. |
|------------|----|-----------|-------------------|------------|----|-----------|-------------------|------------|----|-----------|-------------------|
| 0060748992 | 1 | 43030 | | 0060749575 | 1 | 43050 | | 0060749725 | 1 | 02460 | |
| 0060748994 | 1 | 43030 | | 0060749576 | 3 | 43050 | | 0060749725 | 1 | 02460 | |
| 0060749065 | 1 | 43010 | | 0060749577 | 1 | 43050 | | 0060749752 | 1 | 02460 | |
| 0060749065 | 1 | 43011 | | 0060749578 | 1 | 43050 | | 0060749753 | 1 | 02460 | |
| 0060749099 | 2 | 02400 | | 0060749579 | 2 | 43050 | | 0060749768 | 1 | 41280 | |
| 0060749162 | 4 | 02400 | | 0060749580 | 1 | 43050 | | 0060749769 | 1 | 41280 | |
| 0060749249 | 1 | 43010 | | 0060749581 | 1 | 43050 | | 0060749770 | 1 | 41280 | |
| 0060749251 | 4 | 43010 | | 0060749583 | 1 | 43050 | | 0060749772 | 1 | 41280 | |
| 0060749280 | 4 | 01080 | | 0060749584 | 1 | 43050 | | 0060749773 | 1 | 41280 | |
| 0060749280 | 4 | 01081 | | 0060749585 | 1 | 43050 | | 0060749778 | 1 | 41210 | |
| 0060749287 | 1 | 01321 | | 0060749586 | 1 | 43050 | | 0060749780 | 1 | 41210 | |
| 0060749288 | 1 | 01321 | | 0060749587 | 1 | 43050 | | 0060749781 | 4 | 41210 | |
| 0060749505 | 2 | 42080 | | 0060749588 | 1 | 43050 | | 0060749782 | 1 | 41210 | |
| 0060749506 | 2 | 42080 | | 0060749589 | 1 | 43050 | | 0060749783 | 1 | 41210 | |
| 0060749507 | 2 | 42080 | | 0060749591 | 2 | 14400 | | 0060749784 | 1 | 41210 | |
| 0060749508 | 1 | 42080 | | 0060749592 | 2 | 14400 | | 0060749785 | 2 | 41210 | |
| 0060749509 | 1 | 42080 | | 0060749596 | 1 | 43030 | | 0060749786 | 1 | 41210 | |
| 0060749510 | 4 | 42080 | | 0060749597 | 1 | 43030 | | 0060749787 | 1 | 41210 | |
| 0060749511 | 1 | 42080 | | 0060749598 | 1 | 43030 | | 0060749788 | 1 | 41210 | |
| 0060749512 | 2 | 42080 | | 0060749599 | 1 | 43030 | | 0060749796 | 1 | 02700 | |
| 0060749513 | 1 | 42080 | | 0060749600 | 1 | 43030 | | 0060749831 | 4 | 02400 | |
| 0060749514 | 1 | 42080 | | 0060749612 | 1 | 01320 | | 0060749850 | 1 | 11101 | |
| 0060749515 | 1 | 42080 | | 0060749613 | 1 | 01320 | | 0060749850 | 1 | 21120 | |
| 0060749516 | 1 | 42080 | | 0060749614 | 1 | 01320 | | 0060749852 | 1 | 21120 | |
| 0060749517 | 2 | 42080 | | 0060749628 | 1 | 43010 | | 0060749868 | 1 | 21510 | |
| 0060749518 | 1 | 42080 | | 0060749630 | 1 | 02400 | | 0060749868 | 2 | 21610 | |
| 0060749519 | 2 | 42080 | | 0060749633 | 4 | 02400 | | 0060749868 | 2 | 21615 | |
| 0060749520 | 2 | 42080 | | 0060749643 | 2 | 02400 | | 0060749869 | 1 | 41251 | |
| 0060749521 | 2 | 42080 | | 0060749645 | 1 | 02400 | | 0060749881 | 1 | 21510 | |
| 0060749522 | 1 | 42080 | | 0060749646 | 1 | 02400 | | 0060749882 | 1 | 21510 | |
| 0060749524 | 1 | 42080 | | 0060749670 | 4 | 02400 | | 0060749884 | 1 | 21510 | |
| 0060749525 | 1 | 42080 | | 0060749672 | 4 | 02400 | | 0060749890 | 1 | 21610 | |
| 0060749526 | 1 | 42080 | | 0060749690 | 2 | 02400 | | 0060749890 | 1 | 21615 | |
| 0060749527 | 1 | 42080 | | 0060749695 | 1 | 02400 | | 0060749981 | 1 | 43010 | |
| 0060749528 | 1 | 42080 | | 0060749696 | 1 | 02400 | | 0060749982 | 1 | 43010 | |
| 0060749529 | 1 | 42080 | | 0060749698 | 1 | 02031 | | 0060749982 | 1 | 43011 | |
| 0060749530 | 2 | 42080 | | 0060749703 | | 01320 | | 0060750033 | 1 | 02460 | |
| 0060749531 | 1 | 42080 | | 0060749703 | | 01321 | | 0060750035 | 4 | 02400 | |
| 0060749532 | 1 | 42080 | | 0060749704 | | 01320 | | 0060750038 | 4 | 02400 | |
| 0060749533 | 1 | 42080 | | 0060749704 | | 01321 | | 0060750039 | 4 | 02400 | |
| 0060749534 | 1 | 42080 | | 0060749705 | | 01321 | | 0060750053 | 1 | 41251 | |
| 0060749535 | 1 | 42080 | | 0060749706 | | 01320 | | 0060750065 | 1 | 41001 | |
| 0060749536 | 4 | 42080 | | 0060749706 | | 01321 | | 0060750067 | 4 | 02400 | |
| 0060749537 | 1 | 42080 | | 0060749713 | 1 | 02460 | | 0060750074 | 1 | 41251 | |
| 0060749570 | 1 | 43050 | | 0060749716 | 1 | 02460 | | 0060750075 | 1 | 41251 | |
| 0060749571 | 1 | 43050 | | 0060749716 | 1 | 02461 | | 0060750077 | 1 | 41251 | |
| 0060749572 | 1 | 43050 | | 0060749718 | 1 | 02460 | | 0060750112 | 1 | 21120 | |
| 0060749573 | 1 | 43050 | | 0060749718 | 1 | 02461 | | 0060750113 | 1 | 21120 | |
| 0060749574 | 1 | 43050 | | 0060749724 | 1 | 02460 | | 0060750199 | 1 | 43011 | |

INDICE NUMERICO AL BOLLETT. N 01033 DEL CATALOGO S 32

| CATEGORICO | Q. | COD. TAV. | C. SOSTITUENTE M. | CATEGORICO | Q. | COD. TAV. | C. SOSTITUENTE M. | CATEGORICO | Q. | COD. TAV. | C. SOSTITUENTE M. |
|------------|----|-----------|-------------------|------------|----|-----------|-------------------|------------|----|-----------|-------------------|
| 0060750200 | 1 | 43011 | | 0060750437 | 4 | 01321 | | 0060750701 | 1 | 01320 | |
| 0060750201 | 1 | 43011 | | 0060750438 | 4 | 01321 | | 0060750701 | 1 | 01326 | |
| 0060750202 | 1 | 43011 | | 0060750445 | 4 | 01321 | | 0060750702 | 1 | 01320 | |
| 0060750203 | 4 | 43011 | | 0060750457 | 1 | 12001 | | 0060750702 | 1 | 01326 | |
| 0060750204 | 1 | 21610 | | 0060750465 | 1 | 2.523 | | 0060750703 | 1 | 01320 | |
| 0060750204 | 1 | 21615 | | 0060750466 | 1 | 21615 | | 0060750703 | 1 | 01326 | |
| 0060750205 | 1 | 21610 | | 0060750472 | 1 | 21615 | | 0060750720 | 1 | 01090 | |
| 0060750205 | 1 | 21615 | | 0060750483 | 4 | 01080 | | 0060750721 | 1 | 01070 | |
| 0060750206 | 1 | 21610 | | 0060750483 | 4 | 01081 | | 0060750773 | 1 | 21520 | |
| 0060750206 | 1 | 21615 | | 0060750488 | 1 | 01320 | | 0060750774 | 1 | 21520 | |
| 0060750207 | 1 | 21610 | | 0060750488 | 1 | 01326 | | 0060750775 | 1 | 21520 | |
| 0060750207 | 1 | 21615 | | 0060750489 | 1 | 01320 | | 0060750776 | 1 | 21520 | |
| 0060750208 | 1 | 21610 | | 0060750489 | 1 | 01326 | | 0060750788 | 1 | 02400 | |
| 0060750208 | 1 | 21615 | | 0060750490 | 1 | 01320 | | 0060750789 | 1 | 01321 | |
| 0060750209 | 1 | 21610 | | 0060750490 | 1 | 01326 | | 0060750790 | 1 | 01321 | |
| 0060750209 | 1 | 21615 | | 0060750492 | 1 | 01320 | | 0060750791 | 1 | 01321 | |
| 0060750210 | 1 | 21610 | | 0060750492 | 1 | 01326 | | 0060750792 | 1 | 01321 | |
| 0060750210 | 1 | 21615 | | 0060750497 | 1 | 01320 | | 0060750793 | 1 | 01321 | |
| 0060750213 | 1 | 02461 | | 0060750497 | 1 | 01326 | | 0060750794 | 1 | 01321 | |
| 0060750214 | 1 | 02461 | | 0060750498 | 1 | 01320 | | 0060750794 | 1 | 01325 | |
| 0060750215 | 2 | 02461 | | 0060750498 | 1 | 01326 | | 0060750795 | 1 | 21510 | |
| 0060750216 | 1 | 02461 | | 0060750499 | 1 | 01320 | | 0060750796 | 1 | 21520 | |
| 0060750217 | 1 | 02461 | | 0060750499 | 1 | 01326 | | 0060750811 | 1 | 01321 | |
| 0060750218 | 1 | 02461 | | 0060750500 | 1 | 01320 | | 0060750811 | 1 | 01325 | |
| 0060750219 | 1 | 02461 | | 0060750500 | 1 | 01326 | | 0060750811 | 1 | 01326 | |
| 0060750220 | 1 | 02461 | | 0060750512 | 1 | 11300 | | 0060750812 | 1 | 01321 | |
| 0060750221 | 1 | 41280 | | 0060750513 | 1 | 11209 | | 0060750812 | 1 | 01325 | |
| 0060750222 | 8 | 01080 | | 0060750514 | - | 11310 | | 0060750812 | 1 | 01326 | |
| 0060750222 | 8 | 01081 | | 0060750515 | 1 | 11210 | | 0060750813 | 1 | 01321 | |
| 0060750392 | 1 | 41251 | | 0060750519 | 1 | 01320 | | 0060750813 | 1 | 01325 | |
| 0060750414 | 1 | 02700 | | 0060750519 | 1 | 01326 | | 0060750814 | 1 | 01010 | |
| 0060750419 | 1 | 01010 | | 0060750538 | 1 | 11210 | | 0060750815 | 1 | 01321 | |
| 0060750420 | 8 | 01321 | | 0060750598 | 1 | 09000 | | 0060750815 | 1 | 01325 | |
| 0060750421 | 8 | 01321 | | 0060750629 | 1 | 32060 | | 0060750816 | 1 | 01321 | |
| 0060750422 | 8 | 01321 | | 0060750630 | 1 | 32060 | | 0060750816 | 1 | 01325 | |
| 0060750423 | 6 | 01321 | | 0060750645 | 1 | 01010 | | 0060750817 | 1 | 01321 | |
| 0060750424 | 6 | 01321 | | 0060750646 | 1 | 01320 | | 0060750817 | 1 | 01325 | |
| 0060750425 | 6 | 01321 | | 0060750647 | 1 | 01320 | | 0060750818 | 1 | 01321 | |
| 0060750426 | 6 | 01321 | | 0060750648 | 1 | 01320 | | 0060750818 | 1 | 01325 | |
| 0060750427 | 4 | 01321 | | 0060750649 | 1 | 01320 | | 0060750819 | 1 | 01321 | |
| 0060750428 | 4 | 01321 | | 0060750650 | 1 | 01320 | | 0060750820 | 1 | 01321 | |
| 0060750429 | 4 | 01321 | | 0060750652 | 1 | 01900 | | 0060750821 | 1 | 01321 | |
| 0060750430 | 4 | 01321 | | 0060750678 | 1 | 01320 | | 0060750822 | 1 | 01321 | |
| 0060750431 | 4 | 01321 | | 0060750679 | 1 | 01320 | | 0060750822 | 1 | 01325 | |
| 0060750432 | 4 | 01321 | | 0060750680 | 1 | 01320 | | 0060750823 | 1 | 01321 | |
| 0060750433 | 4 | 01321 | | 0060750698 | 1 | 01320 | | 0060750823 | 1 | 01325 | |
| 0060750434 | 4 | 01321 | | 0060750698 | 1 | 01326 | | 0060750824 | 1 | 01321 | |
| 0060750435 | 4 | 01321 | | 0060750700 | 1 | 01320 | | 0060750824 | 1 | 01325 | |
| 0060750436 | 4 | 01321 | | 0060750700 | 1 | 01326 | | 0060750825 | 1 | 01900 | |

INDICE NUMERICO AL BOLLETT. N 01033 DEL CATALOGO S 32

| CATEGORICO | Q. | COD. TAV. | C. SOSTITUENTE M. | CATEGORICO | Q. | COD. TAV. | C. SOSTITUENTE M. | CATEGORICO | Q. | COD. TAV. | C. SOSTITUENTE M. |
|------------|----|-----------|-------------------|------------|----|-----------|-------------------|----------------|----|-----------|-------------------|
| 0060750826 | 1 | 01091 | | 0060755010 | 1 | 41211 | | 0067099987 | | 02031 | |
| 0060750827 | 1 | 01091 | | 0060755010 | 1 | 41273 | | 0079074706 | 4 | 43011 | |
| 0060750829 | 1 | 09000 | | 0060755011 | 1 | 41211 | | 0079075883 | 2 | 43011 | |
| 0060750832 | 1 | 01321 | | 0060755011 | 1 | 41273 | | 0082305237 | 1 | 41211 | |
| 0060750832 | 1 | 01325 | | 0060755012 | 1 | 41211 | | 0082305237 | 1 | 41273 | |
| 0060750833 | 1 | 01321 | | 0060755012 | 1 | 41273 | | 0082416870 | 1 | 02116 | |
| 0060750833 | 1 | 01325 | | 0060755014 | 1 | 41211 | | 0096585243 | 5 | 31200 | |
| 0060750834 | 1 | 01321 | | 0060755015 | 2 | 01091 | | 0096585658 | 1 | 02045 | |
| 0060750834 | 1 | 01325 | | 0060755017 | 2 | 01090 | | 0096586826 | 1 | 02035 | |
| 0060750835 | 1 | 01321 | | 0060755018 | 2 | 01321 | | 0096586846 | 1 | 41210 | |
| 0060750835 | 1 | 01325 | | 0060755018 | 2 | 01325 | | 0096586851 | 8 | 01321 | |
| 0060750836 | 1 | 01321 | | 0060755019 | 2 | 01320 | | 0096609618 | 1 | 01321 | |
| 0060750836 | 1 | 01325 | | 0060755019 | 2 | 01321 | | 0096609619 | 1 | 01321 | |
| 0060750838 | 1 | 21521 | | 0060755019 | 2 | 01325 | | 0096609620 | 1 | 01321 | |
| 0060750839 | 1 | 01325 | | 0060755019 | 2 | 01326 | | 0096609621 | 1 | 01321 | |
| 0060750860 | 1 | 01325 | | 0060755020 | 1 | 01321 | | 0096609637 | 6 | 01321 | |
| 0060750861 | 1 | 01325 | | 0060755020 | 1 | 01325 | | 0096609637 | 1 | 02805 | |
| 0060750862 | 1 | 01325 | | 0060755022 | 1 | 01320 | | 0096609690 | 1 | 41273 | |
| 0060750863 | 1 | 01325 | | 0060755022 | 1 | 01326 | | 0096609943 | 1 | 12120 | |
| 0060750864 | 1 | 01325 | | 0060755023 | 1 | 02321 | | 0096609970 | 1 | 01060 | |
| 0060750865 | 1 | 01325 | | 0060755024 | 1 | 02321 | | 0096609974 | 1 | 01065 | |
| 0060750866 | 1 | 01325 | | 0060755025 | 1 | 02321 | | 0096609975 | 4 | 01080 | |
| 0060750877 | 1 | 01010 | | 0060755026 | 1 | 02321 | | 0096609975 | 4 | 01081 | |
| 0060750890 | | 01326 | | 0060755027 | 1 | 02321 | | 0096609976 | 1 | 12000 | |
| 0060750891 | 1 | 01326 | | 0060755045 | 1 | 02330 | | 0096609988 | 1 | 12001 | |
| 0060750892 | | 01326 | | 0060755046 | 1 | 02330 | | 0096609989 | 1 | 12001 | |
| 0060750893 | 1 | 01326 | | 0060755048 | 4 | 01080 | | 0096676032 | 1 | 02805 | |
| 0060750894 | 1 | 01326 | | 0060755048 | 4 | 01081 | | 00983722000000 | 1 | 43050 | C 09983722000000 |
| 0060750906 | 1 | 01326 | | 0060765000 | 1 | 21100 | | 0210008066 | 8 | 02800 | |
| 0060750907 | 1 | 01326 | | 0060765001 | 1 | 21100 | | 0210008066 | 8 | 02805 | |
| 0060750908 | 1 | 01326 | | 0060765002 | 2 | 21100 | | 0210008119 | 2 | 32360 | |
| 0060752001 | 1 | 41211 | | 0060765002 | 2 | 21120 | | 0210009434 | 3 | 01080 | |
| 0060752001 | 1 | 41273 | | 0067099712 | | 02040 | | 0210009434 | 1 | 01081 | |
| 0060752002 | 1 | 41211 | | 0067099720 | | 02040 | | 02100163390000 | 1 | 02600 | |
| 0060752002 | 1 | 41273 | | 0067099733 | | 04110 | | 02100163390000 | 2 | 32100 | |
| 0060754003 | 8 | 02060 | | 0067099733 | | 04111 | | 02100163400000 | 3 | 04110 | |
| 0060755000 | 4 | 02460 | | 0067099738 | | 11100 | | 02100163400000 | 3 | 04111 | |
| 0060755002 | 2 | 02460 | | 0067099742 | | 31011 | | 02100163400000 | 3 | 04115 | M |
| 0060755003 | 1 | 02460 | | 0067099751 | | 41000 | | 02100163400000 | 2 | 21000 | |
| 0060755004 | 4 | 02160 | | 0067099762 | 1 | 02045 | | 02100163440000 | 4 | 32100 | C 02102163440000 |
| 0060755005 | 2 | 41211 | | 0067099774 | | 04115 | | 02100314000000 | 2 | 02350 | N |
| 0060755005 | 2 | 41273 | | 0067099774 | | 02031 | | 02100314050000 | 1 | 02061 | N |
| 0060755006 | 2 | 41211 | | 0067099774 | | 02036 | | 02100314050000 | 2 | 02640 | |
| 0060755006 | 2 | 41273 | | 0067099780 | | 04110 | | 02100314080000 | 4 | 02060 | M |
| 0060755007 | 1 | 41211 | | 0067099780 | | 04111 | | 02100314080000 | 6 | 02701 | |
| 0060755007 | 1 | 41273 | | 0067099780 | | 04115 | | 02100314080000 | 6 | 02702 | |
| 0060755008 | 1 | 41211 | | 0067099782 | | 02040 | | 02100314080000 | 4 | 02735 | N |
| 0060755008 | 1 | 41273 | | 0067099784 | | 21000 | | 02100314080000 | 1 | 02840 | |
| 0060755009 | 1 | 41273 | | 0067099784 | | 21003 | | 02100314080000 | 1 | 02841 | R |

| | 1 | 2 | 3 | 4 | | | | | | | | | | | | | | | |
|-----------|-----------|--|-----------|-----------|------|------|-------|---|-------|---|-------|---|-------|---|-------|---|---------|---|--|
| T | | | | | | | | | | | | | | | | | | | |
| 5 | 6 | 7 | 8 | 9 | | | | | | | | | | | | | | | |
| | | | | | | | | | | | | | | | | | | | |
| 10 | 11 | 12 | 13 | 14 | | | | | | | | | | | | | | | |
| | | | | | | | | | | | | | | | | | | | |
| 15 | 16 | 17 | | | | | | | | | | | | | | | | | |
| | | <ul style="list-style-type: none"> - Indice di comparazione tra codice tavolo e lettera della colonna - Répertoire numeros de planches lettres de colonnes - Table code-to-column letter cross-reference - Index für die Zuordnung der Kennzahl der Tafel zum her-suchstaben der Spalte - Índice de comparación entre código columna y letra de la columna <table border="1" style="margin-left: auto; margin-right: auto;"> <thead> <tr> <th>TAV.</th> <th>COL.</th> <th>TAV.</th> <th>COL.</th> </tr> </thead> <tbody> <tr> <td>01.01</td> <td>C</td> <td>02.11</td> <td>E</td> </tr> <tr> <td>01.02</td> <td>C</td> <td>02.43</td> <td>E</td> </tr> <tr> <td>01.04</td> <td>C</td> <td>02.43/1</td> <td>E</td> </tr> </tbody> </table> | TAV. | COL. | TAV. | COL. | 01.01 | C | 02.11 | E | 01.02 | C | 02.43 | E | 01.04 | C | 02.43/1 | E | |
| TAV. | COL. | TAV. | COL. | | | | | | | | | | | | | | | | |
| 01.01 | C | 02.11 | E | | | | | | | | | | | | | | | | |
| 01.02 | C | 02.43 | E | | | | | | | | | | | | | | | | |
| 01.04 | C | 02.43/1 | E | | | | | | | | | | | | | | | | |

INDICE NUMERICO AL BOLLETT. N 01033 DEL CATALOGO S 32

| CATEGORICO | Q. | COD. TAV. | C. M. | SOSTITUENTE | CATEGORICO | Q. | COD. TAV. | C. M. | SOSTITUENTE | CATEGORICO | Q. | COD. TAV. | C. M. | SOSTITUENTE |
|----------------|----|-----------|-------|-------------|----------------|----|-----------|-------|----------------|----------------|----|-----------|-------|----------------|
| 02100814080000 | 1 | 02845 | M | | 02100814370000 | 1 | 04000 | R | | 02142166730000 | 1 | 02036 | M | |
| 02100814080000 | 7 | 04100 | | | 02100814370000 | 4 | 04001 | | | 02145166640000 | 2 | 02030 | | |
| 02100814080000 | 7 | 04105 | M | | 02100814370000 | 2 | 12000 | | | 02145166640000 | 2 | 02035 | M | |
| 02100814080000 | 6 | 21500 | R | | 02100814370000 | 13 | 12020 | | | 02160175980000 | 1 | 32110 | C | 02160188190000 |
| 02100814080000 | 6 | 21501 | | | 02100814370000 | 8 | 31010 | | | 02300525060000 | 2 | 02040 | | |
| 02100814140000 | 2 | 02705 | M | | 02100814370000 | 14 | 31120 | | | 02300525060000 | 3 | 02045 | R | |
| 02100814140000 | 1 | 02800 | M | | 02100814370000 | 4 | 32250 | | | 0234035068 | 1 | 31010 | | |
| 02100814310000 | 3 | 12200 | | | 02100814370000 | 2 | 42010 | | | 0236031503 | 1 | 02805 | | |
| 02100814310000 | 1 | 12221 | M | | 02100814400000 | 2 | 01400 | | | 02365361080000 | 4 | 01080 | | |
| 02100814340000 | 2 | 02030 | | | 02100814400000 | 2 | 01401 | | | 02365361080000 | 4 | 01081 | R | |
| 02100814340000 | 2 | 02035 | M | | 02100814400000 | 2 | 01405 | M | | 02370314830000 | 1 | 02116 | M | |
| 02100814340000 | 18 | 02600 | | | 02100814400000 | 1 | 12120 | | | 0240056001 | 5 | 31200 | | |
| 02100814340000 | 18 | 02601 | | | 02100814400000 | 4 | 21500 | | | 09933301000000 | 1 | 43050 | | |
| 02100814340000 | 6 | 02603 | | | 02100814400000 | 4 | 21501 | | | 09934590000000 | 1 | 43050 | | |
| 02100814340000 | 6 | 02701 | | | 02100814400000 | 4 | 31010 | | | 09934591000000 | 3 | 43050 | | |
| 02100814340000 | 6 | 02702 | | | 02100814400000 | 2 | 31120 | | | 09934592000000 | 1 | 43050 | | |
| 02100814340000 | 22 | 02800 | | | 02105020080000 | 1 | 02845 | M | | 09934593000000 | 1 | 43050 | | |
| 02100814340000 | 22 | 02805 | M | | 02105020080000 | 1 | 04000 | | | 09934595000000 | 1 | 43050 | | |
| 02100814340000 | 8 | 02840 | | | 02105020080000 | 1 | 04001 | | | 09983359000000 | 1 | 43050 | | |
| 02100814340000 | 8 | 02841 | R | | 02105020100000 | 2 | 04000 | A | | 09983716000000 | 1 | 43050 | | |
| 02100814340000 | 7 | 02845 | M | | 02105020100000 | 3 | 04001 | A | | 09983718000000 | 1 | 43050 | | |
| 02100814340000 | 4 | 04000 | | | 02105020100000 | 5 | 12000 | A | | 09983722000000 | 1 | 43050 | V | |
| 02100814340000 | 4 | 04001 | | | 02105020170000 | 6 | 02702 | | | 10142400000000 | 1 | 12020 | | |
| 02100814340000 | 1 | 04100 | | | 02105043380000 | 1 | 02805 | C | 02105043300000 | 10195300000000 | 4 | 32060 | R | |
| 02100814340000 | 1 | 04105 | M | | 02105163390000 | 2 | 02355 | M | | 10255500000000 | 6 | 41000 | | |
| 02100814340000 | ? | 11200 | | | 02105163390000 | 1 | 04105 | M | | 10255500000000 | 6 | 41006 | M | |
| 02100814340000 | 6 | 21500 | | | 02105163410000 | 1 | 02735 | C | 02100163410000 | 10275100000000 | 2 | 01041 | C | 10257100000000 |
| 02100814340000 | 3 | 12000 | | | 02105325620000 | 4 | 04100 | | | 10441000000000 | 2 | 02035 | C | 11044100000000 |
| 02100814340000 | 15 | 12020 | | | 02105325620000 | 4 | 04105 | M | | 10474700000000 | 1 | 04115 | C | 10747000000000 |
| 02100814340000 | 1 | 12120 | | | 02105814050000 | 2 | 02355 | M | | 10776000000000 | 2 | 41000 | | |
| 02100814340000 | 12 | 14400 | | | 02105814050000 | 1 | 04105 | M | | 10776000000000 | 2 | 41006 | N | |
| 02100814340000 | 4 | 21100 | | | 02105814080000 | 2 | 02061 | M | | 10998600000000 | | 01320 | C | |
| 02100814340000 | 3 | 21710 | | | 02105814080000 | 2 | 02350 | M | | 10998800000000 | 1 | 01320 | C | |
| 02100814340000 | 4 | 31070 | | | 02105814080000 | 2 | 02737 | M | | 10998900000000 | 1 | 01320 | C | |
| 02100814340000 | 2 | 31110 | | | 02105814080000 | 1 | 21000 | | | 10999000000000 | 1 | 01320 | C | |
| 02100814340000 | 1 | 32050 | | | 02105814080000 | 2 | 41001 | C | 02105814090000 | 11007500000000 | 1 | 01321 | C | |
| 02100814340000 | 1 | 42010 | | | 02105814080000 | 1 | 02037 | M | | 11007600000000 | 1 | 01321 | C | |
| 02100814340000 | 1 | 42050 | | | 02105814080000 | 2 | 02060 | M | | 11007700000000 | 1 | 01321 | C | |
| 02100814350000 | 2 | 01040 | | | 02105814090000 | 2 | 41001 | V | | 11007800000000 | 1 | 01321 | C | |
| 02100814350000 | 3 | 21720 | | | 02105814090000 | 2 | 41006 | N | | 11007900000000 | 1 | 01321 | C | |
| 02100814350000 | 8 | 31011 | | | 02105814340000 | 6 | 02350 | N | | 11600254600300 | 2 | 14400 | | |
| 02100814350000 | 3 | 32100 | | | 02125150250000 | 1 | 92115 | M | | 11610050600805 | 1 | 43611 | | |
| 02100814370000 | 4 | 01040 | | | 02125150420000 | 1 | 12020 | | | 11610055210300 | 1 | 43011 | | |
| 02100814370000 | 2 | 01041 | | | 02125150420000 | 6 | 31010 | | | 11610651350700 | 1 | 02355 | M | |
| 02100814370000 | 2 | 01400 | | | 02125150420000 | 2 | 31120 | | | 11646880210000 | | 32100 | R | |
| 02100814370000 | 2 | 01401 | | | 02125928220000 | 1 | 31011 | | | 11655173180100 | 12 | 14400 | | |
| 02100814370000 | 2 | 01405 | M | | 02140163510000 | 1 | 31120 | C | 0140165310000 | 11900214250100 | 2 | 21600 | | |
| 02100814370000 | 1 | 02800 | | | 02140166490000 | 1 | 32100 | | | 12562300000000 | 3 | 21600 | | |
| 02100814370000 | 1 | 02805 | M | | 02142166730000 | 1 | 02031 | | | 12562300000000 | 2 | 31110 | | |

T₁₇

SPRINT
Ed. 87
MECCANICA

1 - 1989

INDICE DI COMPARAZIONE TRA CODICE TAVOLA E LETTERA DELLA COLONNA
 REPERTOIR NUMEROS DE PLANCHES LETTRES DE COLONNES
 TABLE CODE - TO - COLUMN LETTER CROSS - REFERENCES
 INDEX FUER DIE ZOURDNUNG DER KENNZAHL DER TAFEL ZUM KENNBUCHST ABEN SPALTE
 INDICE DE COMPARACION ENTRE CODEX LAMINA Y LETRA DE LA COLUMNA

c c 32

| TAV. | COL. | TAV. | COL. | TAV. | COL. | TAV. | COL. | TAV. | COL. | TAV. | COL. | TAV. | COL. |
|---------|------|---------|------|---------|------|---------|------|---------|------|---------|------|------|------|
| 01.01 | C/2 | 01.42 | E/3 | 02.60/1 | G/12 | 04.11/5 | J/9 | 14.40 | N/6 | 31.12 | O/7 | | |
| 01.01/9 | C/1 | 01.42/1 | E/1 | 02.60/3 | G/15 | 09.00 | K/6 | 21.00 | Q/1 | 31.20 | O/10 | | |
| 01.04 | C/3 | 01.90 | K/5 | 02.60/5 | G/16 | 11.10 | L/1 | 21.00 | Q/2 | 32.05 | P/1 | | |
| 01.04/1 | C/7 | 02.03 | F/2 | 02.64 | G/17 | 11.10/1 | L/2 | 21.00/3 | Q/3 | 32.06 | P/2 | | |
| 01.06 | C/4 | 02.03/1 | F/3 | 02.70 | G/1 | 11.20 | L/4 | 21.00/5 | Q/4 | 32.06 | P/3 | | |
| 01.06/5 | C/5 | 02.03/5 | F/15 | 02.70/1 | G/4 | 11.21 | L/5 | 21.02 | Q/5 | 32.10 | P/6 | | |
| 01.08 | C/9 | 02.03/6 | F/16 | 02.70/1 | G/5 | 11.30 | L/7 | 21.10 | Q/6 | 32.11 | P/5 | | |
| 01.08/1 | C/8 | 02.03/7 | F/14 | 02.70/2 | G/2 | 11.31 | L/8 | 21.12 | Q/7 | 32.25 | P/4 | | |
| 01.09 | C/11 | 02.04 | F/1 | 02.70/2 | G/3 | 11.50 | L/10 | 21.50 | Q/10 | 41.00 | H/10 | | |
| 01.09/1 | C/10 | 02.04/5 | F/8 | 02.70/5 | G/8 | 12.00 | M/2 | 21.50/1 | Q/9 | 41.00/1 | H/11 | | |
| 01.20 | C/6 | 02.06 | F/11 | 02.73/5 | F/13 | 12.00 | M/3 | 21.51 | Q/12 | 41.00/6 | H/12 | | |
| 01.31 | D/2 | 02.06/1 | F/12 | 02.73/7 | G/9 | 12.00/1 | M/1 | 21.52 | Q/13 | 41.21 | H/13 | | |
| 01.31/1 | D/1 | 02.11 | F/5 | 02.80 | C/13 | 12.02 | M/4 | 21.52/1 | Q/11 | 41.21/1 | H/15 | | |
| 01.31/5 | D/3 | 02.11/4 | F/7 | 02.80 | C/14 | 12.02 | M/5 | 21.52/3 | Q/14 | 41.25/1 | H/17 | | |
| 01.32 | D/6 | 02.11/5 | F/10 | 02.80/5 | C/15 | 12.12 | M/6 | 21.60 | Q/15 | 41.27/3 | H/14 | | |
| 01.32 | D/7 | 02.11/6 | F/9 | 02.80/5 | C/16 | 12.16 | M/7 | 21.61 | Q/16 | 41.28 | H/16 | | |
| 01.32/1 | D/4 | 02.33 | G/7 | 02.84 | K/2 | 12.16/1 | M/8 | 21.61/5 | Q/17 | 42.01 | I/1 | | |
| 01.32/1 | D/5 | 02.35 | G/6 | 02.84/1 | K/1 | 12.20 | M/9 | 21.71 | R/1 | 42.01 | I/2 | | |
| 01.32/5 | D/8 | 02.35/5 | H/7 | 02.84/5 | K/3 | 12.20 | M/10 | 21.72 | R/4 | 42.05 | I/3 | | |
| 01.32/5 | D/9 | 02.40 | H/3 | 03.10 | E/6 | 12.22 | M/11 | 21.85 | R/1 | 42.08 | I/4 | | |
| 01.32/6 | D/10 | 02.40 | H/4 | 04.00 | J/2 | 12.22 | M/12 | 21.85/1 | L/13 | 42.08 | I/5 | | |
| 01.32/6 | D/11 | 02.40/3 | H/1 | 04.00/1 | J/1 | 12.22/1 | M/13 | 31.00 | N/7 | 43.01 | I/7 | | |
| 01.40 | D/14 | 02.46 | H/5 | 04.10 | J/3 | 12.30 | M/14 | 31.01 | O/1 | 43.01/1 | I/8 | | |
| 01.40 | D/15 | 02.46/1 | H/2 | 04.10/5 | J/4 | 14.10 | N/1 | 31.01/1 | O/2 | 43.03 | I/9 | | |
| 01.40/1 | D/13 | 02.60 | G/13 | 04.10/5 | J/5 | 14.10 | N/2 | 31.07 | O/3 | 43.05 | I/10 | | |
| 01.40/5 | D/16 | 02.60 | G/14 | 04.11 | J/8 | 14.30 | N/3 | 31.11 | O/5 | 43.05 | I/11 | | |
| 01.42 | E/2 | 02.60/1 | G/11 | 04.11/1 | J/7 | 14.30 | N/4 | 31.11 | O/6 | | | | |